

PRODUCT CATALOGUE

Modular Helical & Bevel Helical Gear Unit Series



1. Introduction		1.01
Santasalo modular gear series		1.02
Used abbreviations and standards		1.03
Nominal torque comparison chart		1.04
Type definition		1.05
Santasalo helical gear units		1.07
Santasalo bevel-helical gear units		1.08
Typical drive arrangement		1.09
Selection information		1.10
2. Nominal mechanical power ratings		2.01
Helical gear units, horizontal LSS		
	1-stage	2.02
	2-stage	2.04
	3-stage	2.06
	4-stage	2.08
	4,5-stage	2.09
Bevel-helical gear units, horizontal LSS		
	2-stage	2.10
	3-stage	2.11
	4-stage	2.12
	5-stage	2.13
Helical gear units, vertical LSS		
	2-stage	2.14
	3,4-stage	2.15
Bevel-helical gear units, vertical LSS		
	3,4-stage	2.16
3. Nominal output torque		3.01
4. Thermal ratings		4.01
5. Exact ratios i_{ex}		5.01
6. Continuous allowed external loads		6.01
7. Allowed rotational speed		7.01
Splash/bath lubrication		7.01
Bath lubrication		7.03
Pressure lubrication		7.04
8. Helical gear units, horizontal LSS		8.01
	D1PSF20-130	8.01
	2C140N-250N	8.03
	2TC140N-250N	8.04
	D2P..50-90	8.05
	D2PSF95-160	8.07
	D2PHT100-110	8.09
	3C140N-250N	8.11
	3TC140-250	8.12
	D3P..50-90	8.13
	D3P..100-160	8.15
	4C140N-250N	8.19
	4TC140N-250N	8.20
	D4P..50-90	8.21
	D4P..100-160	8.23
	D5P..100-160	8.27

Dots (...) refer to the type definition. See section 1.05.

9. Bevel-helical gear units, horizontal LSS		9.01
	2KC90M-225M	9.01
	2KC250M-400M	9.02
	2TKC90M-225M	9.03
	2TKC250M-400M	9.04
	3KC140N-250N	9.05
	3TKC140N-250N	9.06
	3TKCV140N-400N	9.07
	D3R..50-95	9.08
	D4R..50-90	9.10
	D4R..100-160	9.12
	5KC160N-250N	9.18
	5TKC160N-250N	9.19
	D5R..50-90	9.20
	D5R..100-160	9.22
	D5RHT100-160	9.24
	D5RUHT100-160	9.26
10. Helical gear units, vertical LSS		10.01
	D2PV..10-50	10.02
	D2PV..60-80	10.04
	D3PV..10-50	10.06
	D3PV..60-90	10.08
	D3PV...100-120	10.10
	D4PV..50	10.12
	D4PV..60-90	10.14
	D4PV...100-120	10.16
11. Bevel-helical gear units, vertical SS		11.01
	D3RV..30-50	11.02
	D3RV..60-90	11.04
	D4RV..50	11.06
	D4RV..60-90	11.08
12. Modular accessories		12.01
	Hollow shaft bore	12.01
	Through going HSS	12.16
	Mounting flange	12.17
	Cooling fans	12.18
	Cooling coil system	12.22
	Lubrication unit	12.23
	Shaft end pump	12.24
	Central lubrication system connections	12.25
	Oil heating system	12.27
	Oil drain valves, oil dipstick	12.28
	Oil sightglass and breather, expansion tank for moist environment	12.29
	Optional seal arrangements	12.30
	Coupling guard, torque arm	12.31
	Belt drive, motor flange	12.32
	Back stop	12.33
	Modifications	12.35
	Modifications D..50-90	12.36
	Modifications D..100-160	12.37

Dots (...) refer to the type definition. See section 1.05.



In step with the increasing demand for greater performance and reliability, the Santasalo modular gear series delivers high performance in heavy duty applications. The modular C-series and D-series, offer a wide range of helical and bevel-helical gear units. These complete and comprehensive modular gear series meet specific application requirements with precision. Gear units from the Santasalo modular gear series can be delivered on a turnkey basis - from 3D planning, engineering and manufacturing complete with accessories all the way to start-up and customer training.

Customisation for best process fit

The C- and D-series are based on modular-design customisation, which combines components and design features for optimum operation. With our know-how in the process industry and advanced engineering processes combined with our flexible order-based manufacturing, the Santasalo modular gear series are readily tailored to meet individual application needs. Versatile mounting positions utilising the application specific modular design as well as various shaft positions demonstrate the high level of flexibility of both modular gear series.

Reliability for high process availability

Reliability springs from design expertise and competence in manufacturing that only solid experience provides. The Santasalo modular gear series is built on decades of experience in layout engineering, complete design of components and manufacturing of gear units for heavy duty applications. All key manufacturing processes are performed in-house to ensure that all process stages achieve a consistently high quality level. Additionally, all gear units serviced at the Santasalo locations are test run prior to delivery to ensure reliable operation. Reliability combined with easy maintenance contributes to maximum uptime and minimum downtime.

Lifecycle support for efficient process performance

The Santasalo modular gear series incorporates flexible design features and comprehensive product support to lower maintenance costs throughout the whole lifecycle of the mechanical drive solution. To increase serviceability, features like a horizontal split plane design, correctly positioned lifting points and generously sized visual inspection covers are taken into account during engineering and design phases. Santasalo can be relied on for upgrades, rebuilds and spare parts according to original design specifications. Application manuals, comprehensive documentation and detailed histories of each gear unit serviced at Santasalo Service Centres facilitate fast and efficient maintenance services.

Used abbreviations and standards

Customisation for best process fit

The selection of the gear unit is a demanding task. The customer supplies the following data: drive specification, duty cycle and operation conditions.

To ensure that the gear unit functions according to the specification, please take Santasalo instructions into consideration, e.g. selection, storage, mounting, lubrication, operation and maintenance of the gear unit.

The system of connected rotating parts must be compatible, free from critical speed as well as torsional and other type vibrations within the specific speed range.

Mounting, operating and maintenance (MOM)

MOM instructions are included in every delivery. When requested, MOM instructions can be supplied in advance.

Definition of icons used in dimensional drawings



Visual inspection opening



Oil drainage



Breather



Oil glass



Oil filter

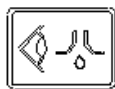

Oil indication in case of leakage

Standards used in dimensional drawings

Keys and keyways: ISO/R773-1969

Shaft height deviations: ISO/496-1973

Screw strength grade of foot mounting face fixing: 6.8

Abbreviations used

LSS - Low Speed Shaft

HSS - High Speed Shaft

Shaft positions

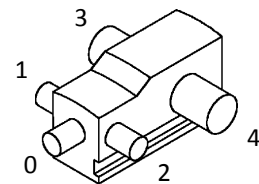
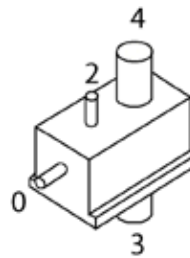



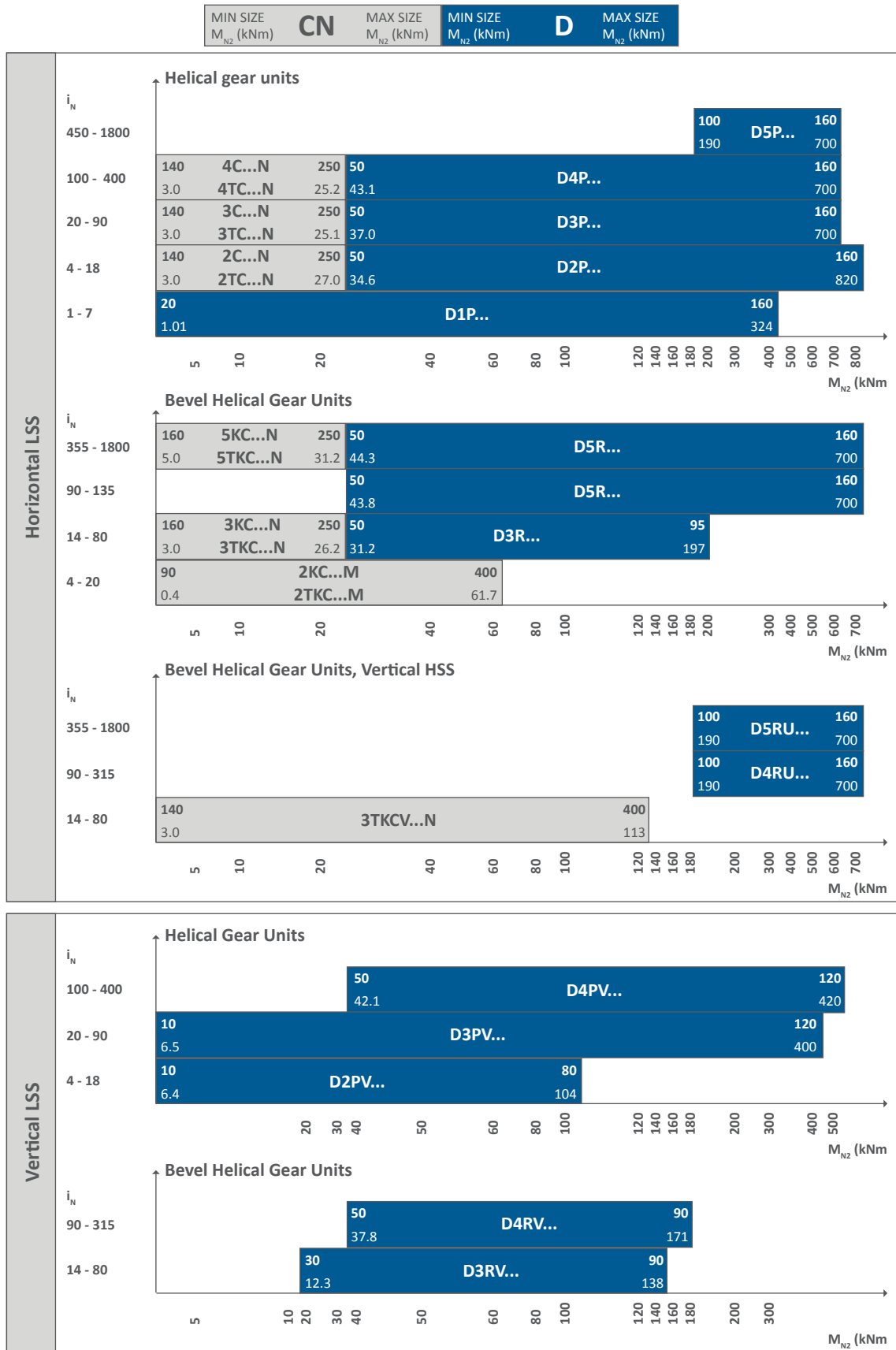

Nominal torque comparison chart

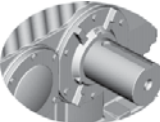

Type definition

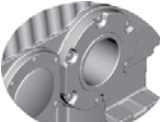
D **3** **P** **S** **F** **100**

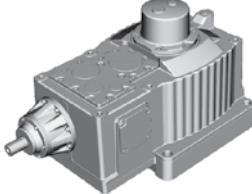
Series	Number of stages	Gear unit design	LSS type	Attachment	Size
D	1	Helical gear unit (Parallel shafts)	S Solid shaft 	F Foot	10
		P Horizontal LSS PV Vertical LSS  			20
					30
		40			
		50			
		60			
	2	Bevel-helical gear unit (Right-angle shafts)	H Hollow shaft 	T Torque arm mounting bracket	70
					80
					90
	3	RV Vertical LSS  RU Horizontal LSS Vertical HSS  R Horizontal LSS 			95
					100
					110
					120
					130
					140
4				150	
				160	

3KC250N

Number of stages (3)

Gear unit series design (KC)

Size (250)

Upgrade (N,M)

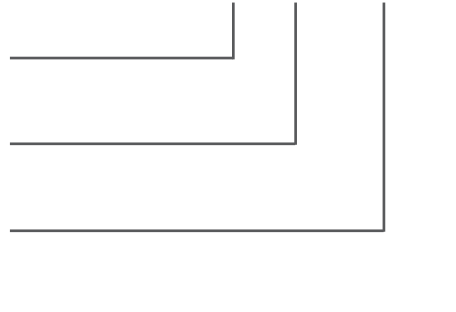

Gear unit design

C

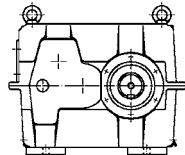

FOOT MOUNTED
HELICAL GEAR UNIT
HORIZONTAL LSS

KC

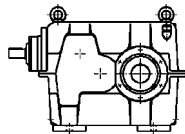

FOOT MOUNTED
BEVEL-HELICAL GEAR UNIT
HORIZONTAL LSS

TC

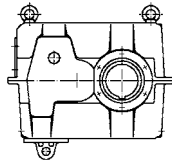

SHAFT MOUNTED
HELICAL GEAR UNIT
HORIZONTAL LSS

TKC

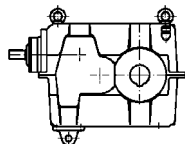

SHAFT MOUNTED
BEVEL-HELICAL GEAR UNIT
HORIZONTAL LSS

TKCV

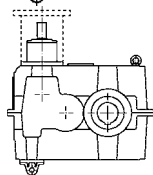

SHAFT MOUNTED
BEVEL-HELICAL GEAR UNIT
VERTICAL HSS
HORIZONTAL LSS

Gear unit types

C

Series (foot mounted, horizontal LSS)

K

































Bevel stage

















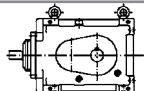
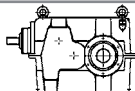
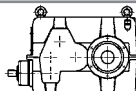

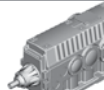

T

Shaft mounted (hollow LSS)

V

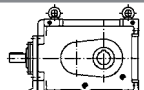
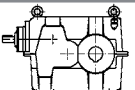
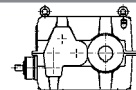
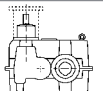
Vertical HSS

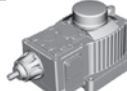
Helical gear units							
No of stages	1	2	3	4	5	Gear series	
Nominal ratio	$i_N=1 - 7$	$i_N=4 - 18$	$i_N=20 - 90$	$i_N=100 - 400$	$i_N=450 - 1800$		
Nom. mech. power	Page 2.02-2.03	Page 2.04-2.05	Page 2.06-2.07	Page 2.08-2.09	Page 2.09		
Horizontal LSS	Solid LSS	 D1PSF20-130 Dimensions 8.01-02	 D2PSF50-90N Dimensions 8.05-8.06	 D3PSF50-90 Dimensions 8.13-8.14	 D4PSF50-90 Dimensions 8.21-8.22	D	
		 D2PSF95-160 Dimensions 8.07-8.08	 D3PSF100-160 Dimensions 8.15-8.16	 D4PSF100-160 Dimensions 8.23-8.24	 D5PSF100-160 Dimensions 8.27-8.28	D	
		 2C140N-250N Dimensions 8.03	 3C140N-250N Dimensions 8.11	 4C140N-250N Dimensions 8.19		C	
		 D2PHT50-90 Dimensions 8.05-8.06	 D3PHT50-90 Dimensions 8.13-8.14	 D4PHT50-90 Dimensions 8.21-8.22		D	
		 D2PHF100-110 Dimensions 8.10	 D3PHF100-160 Dimensions 8.15-8.16	 D4PHF100-160 Dimensions 8.23-8.24	 D5PHF100-160 Dimensions 8.27-8.28	D	
		 D2PHT100-110 Dimensions 8.09-8.10	 D3PHT100-160 Dimensions 8.17-8.18	 D4PHT100-160 Dimensions 8.25-8.26		D	
	 2TC140N-250N Dimensions 8.04	 3TC140N-250N Dimensions 8.12	 4TC140N-250N Dimensions 8.20		C		
	Nom. mech. power	Page 2.02-2.03	Page 2.04-2.05	Page 2.06-2.07	Page 2.08-2.09	Page 2.09	
	Vertical LSS	Solid LSS	 D2PVSF10-80 Dimensions 10.01-05	 D3PVSF10-90 Dimensions 10.06-09	 D4PVSF50-90 Dimensions 10.10-13		D
				 D3PVSF100-120 Dimensions 10.10-11	 D4PVSF100-120 Dimensions 10.14-15		D
		Hollow LSS	 D2PVHF10-80 Dimensions 10.01-05	 D3PVHF10-90 Dimensions 10.06-09	 D4PVHF50-90 Dimensions 10.10-13		D

Bevel-helical gear units							
No of stages	2	3	4	5	Gear series		
	$i_N=4 - 20$	$i_N=14 - 80$	$i_N=90 - 315$	$i_N=355 - 1800$			
Nom. mech. power	Page 2.10	Page 2.11	Page 2.12	Page 2.13			
Horizontal LSS	Solid LSS	 D3RSF50-90 Dimensions 9.08-9.09	 D4RSF50-90 Dimensions 9.12-9.13	 D5RSF50-90 Dimensions 9.22-9.23	D		
		 D3RSF95 Dimensions 9.10-9.11	 D4RSF100-160 Dimensions 9.14-9.15	 D5RSF100-160 Dimensions 9.24-9.25	D		
		 2KC90M-400M Dimensions 9.01-9.02	 3KC140N-250N Dimensions 9.05		 5KC160N-250N Dimensions 9.20	C	
		 D3RHF, RHT50-90 Dimensions 9.08-9.09	 D4RHF, RHT50-90 Dimensions 9.12-9.13	 D5RHF, RHT50-90 Dimensions 9.22-9.23	D		
		 D3RHF, RHT95 Dimensions 9.10-9.11	 D4RHF100-160 Dimensions 9.14-9.15	 D5RHF100-160 Dimensions 9.24-9.25	D		
			 D4RHT100-160 Dimensions 9.16-9.17	 D5RHT100-160 Dimensions 9.26-9.27	D		
	Hollow LSS			 D4RUHT100-160 Dimensions 9.17-9.19	 D5RUHT100-160 Dimensions 9.28-9.29	D	
		 2TKC90M-400M Dimensions 9.03-9.04	 3TKC140N-250N Dimensions 9.06		 5TKC160N-250N Dimensions 9.21	C	
			 3TKCV140N-400N Dimensions 9.07			C	
		Nom. mech. power		Page 2.16	Page 2.16		
		Vertical LSS	Solid LSS	 D3RVSF30-90 Dimensions 11.01-05	 D4RVSF50-90 Dimensions 11.06-09		D
			Hollow LSS	 D3RVHF30-90 Dimensions 11.01-05	 D4RVHF50-90 Dimensions 11.06-09		D

Typical drive arrangement

Horizontal LSS

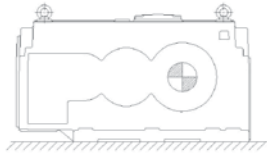

D..SF 50-160

Solid LSS (S)
Foot mounting (F)

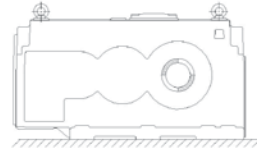

D..HF 50-160

Hollow LSS (H)
Foot mounting (F)

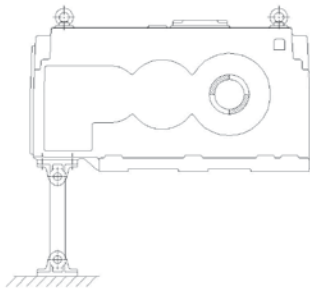

D..HT 50-160

Hollow LSS (H)
Torque arm mounting bracket (T)
Torque arm

Vertical LSS

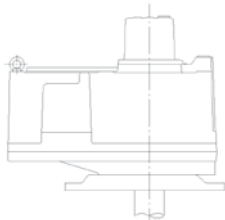

D..VSF 10-50

Solid LSS (S)
Foot mounting (F)
Mounting flange

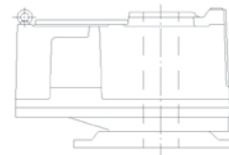

D..VHF 10-50

Hollow LSS (H)
Foot mounting (F)
Mounting flange

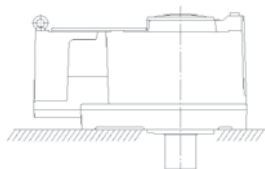

D..VSF 60-120

Solid LSS (S)
Foot mounting (F)

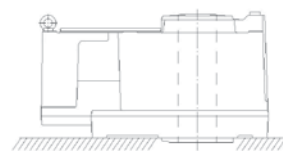

D..VHF 60-90

Hollow LSS (H)
Foot mounting (F)

1. GEAR UNIT SELECTION

1.1 Ratio

Calculate ratio $i = n_1/n_2$ and choose the nearest nominal ratio i_N shown in rating tables. The exact ratios i_{ex} are found in tables (section 2). Choose the gear unit type in conformity with the ratio i_N .

$$(1) \quad i_{ex} = \frac{n_1}{n_2}$$

n_1 = HSS rotation speed (HSS = High speed shaft)
 n_2 = LSS rotation speed (LSS = Low speed shaft)

1.2 Running power P_{K1} , P_{K2} and running torque M_{K2}

single stage	$\eta = 0.985$
double stage	$\eta = 0.97$
triple stage	$\eta = 0.955$
quadruple stage	$\eta = 0.94$
quintuple stage	$\eta = 0.93$
	η = Efficiency

$$(2) \quad P_{K1} = \frac{P_{K2}}{\eta} \quad (3) \quad P_{K1} = \frac{M_{K2} \times n_2}{9550 \times \eta}$$

P_{K1} , P_{K2} [kW], M_{K2} (Nm)

1.3 Gear unit selection by means of F_s

The service factor F_s is determined by the load characteristic of the driving and driven machine. F_s is given in table 2.

Select the size of the gear unit from the rating table so that the nominal power rating P_{N1} meets the requirements relative to ratio i_N and input speed n_1 (HSS):

$$(4) \quad P_{K1} \times F_s \leq P_{N1}$$

1.4 Maximum power P_{K1max} and maximum torque M_{K2max}

$$(5) \quad P_{K1max} \leq \frac{2 \times P_{N1}}{F_f} \quad (6) \quad M_{K2max} \leq \frac{2 \times M_{N2}}{F_f} \frac{P_{N1} \text{ [kW]}}{M_{N2} \text{ [Nm]}}$$

Factor F_f is given in table 3.

The gear unit can be momentarily overloaded. Single load peak should not exceed 10 second period.

1.5 External loads on shaft ends

Check the connections of input (HSS) and output (LSS) shafts and the possible radial and axial loads on shaft ends.

1.6 Reversing drive

Power ratings P_{N1} and torque ratings M_{N2} given in tables are calculated for constant load direction. When rotation direction changes with full load once per minute, 70% of P_{N1} and M_{N2} can be utilised.

1.7 Thermal rating

The thermal rating P_T is the actual power rating the gear unit can transmit continuously without exceeding the calculated oil temperature.

$$(7) \quad P_T = P_{TH} \times f_1$$

f_1 = factor for altitude, see table 1.

Determine the thermal rating P_T of the gear unit in the actual ambient temperature. If $P_{K1} > P_T$, check if external pressure lubrication and cooling unit can be used.

$$(8) \quad P_{K1} \leq P_T$$

Selection information

Table 1. Factor for altitude f_1

	Altitude (meters above sea)				
	0	1000	2000	3000	4000
f_1	1.0	0.95	0.91	0.87	0.83

f_1 = Intermediate values have to be interpolated.

1.8 Lubrication method

Check from the rating table the lubrication method of the selected gear unit.

1.9 Noise level

Estimated sound pressure level $L_p(A)$ applies only in free-field conditions at one (1) meter distance from the gear unit surface. Guaranteed $L_p(A)$ values are given by Santasalo when requested.

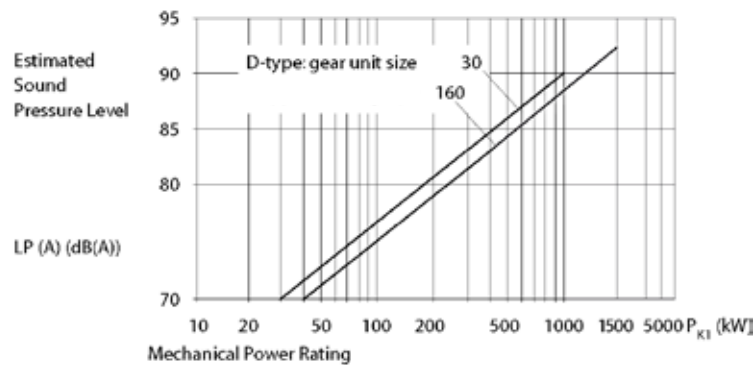

1.10 Final selection

Santasalo is responsible for selecting the right gear unit. The buyer is responsible for giving the correct load cases and technical requirements.

Table 2. Service factor F_s (U, M, C, H see table 4)

Driving machine (prime mover)	Load classification of driven machine	Service hours per day		
		<3	3...10	>10
Electric motor, steam or gas turbine, water turbine, hydraulic motor/electro-motor	Group U	1.00	1.10	1.25
	Group M	1.15	1.25	1.50
	Group C	1.35	1.50	1.75
	Group H	1.55	1.75	2.00
Multicylinder combustion engine	Group U	1.15	1.25	1.50
	Group M	1.35	1.50	1.75
	Group C	1.55	1.75	2.00
	Group H	1.80	2.00	2.25

These service factors are given as a general guide only. For exceptional working conditions, such as extreme shock loads, frequent starts on full load, reversing drive, rapid acceleration or deceleration, function near to critical speed, braking, high external loads on shaft ends and exceptional ambient conditions, reference to Santasalo is recommended.

Table 3. Maximum load occurrence factor F_F

Maximum load occurrence / hour	1...5	6...20	21...40	41...80	81...160	>160
F_F	1.00	1.20	1.30	1.50	1.75	2.00

2. Examples of selection

Driven machine

Load class (table 4)
 Rotation speed n_2
 P_{k2} or M_{k2}
 Load peaks (P_{k2max} or M_{k2max})
 Duration of service
 Starting frequency

Driving machine

Nominal power rating / rot. speed

Gear unit type

Shaft position
 Hollow shaft bore dia

Connections

Motor - gear unit
 Gear unit-driven machine

Ambient conditions

Temperature
 Other conditions

Selection of gear unit

$n_1/n_2 = i$
 Nearest nominal ratio i_N
 Gear unit type (efficiency)
 Required F_s (table 1)

$$P_{k1} = \frac{P_{k2}}{\eta} = \frac{M_{k2} \times n_2}{9550 \times \eta}$$

Selected gear unit

$$P_{k1} \times F_s < P_{N1}$$

Example 1

Stone crusher

Group H
 75 min⁻¹
 850 kW
 1500 kW
 10 h/d, 2400 h/a
 1 start per hour

Squirrel cage motor
 900 kW / 1482 min⁻¹

Foot mounted
 Horizontal, parallel

Flexible coupling
 Gear coupling

-30...+30°C
 Very dusty

1482/75=19.76:1
 20:1
 D3PSF ($\eta = 0.955$)
 2.0

890.1 kW
 D3PSF110
 890.1 kW x 2.0 < 2062 kW

Selection check and application requirements

Gear unit exact ratio i_{ex}

20.032

Checking of P_{k2max} and M_{k2max}

D3PSF110 meets the requirements

Thermal rating P_T

389 kW (by ambient temperature +30°C)

Cooling devices

External cooling system with pressure lubrication if needed

Lubrication method

Pressurised lubrication

Requirements of very dusty or moist conditions

Labyrinth seal grease on LSS and HSS

Requirements of cold ambient temperature (cold start etc)

Use of synthetic PAO oil

Selection information

2. Examples of selection

	Example 1	Example 2
Driven machine	Stone crusher	Vacuum filter
Load class (table 4)	Group H	Group M
Rotation speed n_2	130 min ⁻¹	0.8...4.3 min ⁻¹
P_{k2} or M_{k2}	350 kW	41000 Nm
Load peaks (P_{k2max} or M_{k2max})	650 kW	48000 Nm
Duration of service	10 h/d, 2400 h/a	24 h/d, 8000 h/a
Starting frequency	1 start per hour	seldom
Driving machine	Squirrel cage motor	DC motor
Nominal power rating / rot. speed	355 kW / 1482 min ⁻¹	5-26 kW / 250-1500 min ⁻¹
Gear unit type	Foot mounted	Hollow shaft
Shaft position	Horizontal, parallel	Horizontal, right angle
Hollow shaft bore dia	----	180 mm
Connections		
Motor - gear unit	Flexible coupling	V-belt drive 1:1
Gear unit-driven machine	Gear coupling	Hollow shaft, shrink disc
Ambient conditions		
Temperature	-30...+30°C	+35°C
Other conditions	Very dusty	Moist
Selection of gear unit		
$n_1/n_2 = i$	1482/130=11.4:1	1500/4.4=348.8:1
Nearest nominal ratio i_N	11.2:1	355.1
Gear unit type (efficiency)	D2PSF ($\eta = 0.97$)	D5RHT ($\eta = 0.93$)
Required FS (table 1)	1.75	1.5
$P_{k1} = \frac{P_{k2}}{\eta} = \frac{M_{k2} \times n_2}{9550 \times \eta}$		
	360.8 kW	19.9 kW
Selected gear unit	D2PSF60	D5RHT60
$P_{k1} \times F_S < P_{N1}$	360.8 kW x 1.75 < 822 kW	19.9 kW x 1.5 < 33.5 kW

Selection check and application requirements

Gear unit exact ratio i_{ex}	11.189	352.66
Checking of P_{k2max} and M_{k2max}	D2PSF60 meets the requirements	D5RHT60 meets the requirements
Thermal rating P_T	202 kW (by ambient temperature +30°C)	60 kW
Cooling devices	Water cooling coil or external cooling system with pressure lubrication if needed	Cooling not required
Lubrication method	Splash lubrication	Bath lubrication
Requirements of very dusty or moist conditions	Labyrinth seal as standard on LSS and HSS	----
Requirements of cold ambient temperature (cold start etc)	Use of synthetic PAO oil	----

Selection information

Table 4.
Load classification of the driven machine

Group U = uniform load
Group C = considerable shocks

Group M = moderate shocks
Group H = heavy shocks

Application	Group	Application	Group	Application	Group
Agitators and mixers		Flattening machines	*	Reels	C
Concrete	C	Slitters	H	Rolls (pick up, wire drive, wire suction)	C
Liquids (constant density) and solids	U	Table conveyors, non-reversing		Screw presses	H
Liquids (variable density)	M	- group drives	C	Washers	M
Blowers and fans	M	- individual drives	H	Yankee cylinders (dryers)	*
Compressors		Table conveyors, reversing	*	Plastics and rubber industry	
Centrifugal	U	Wire drawing machines	C	Calenders and grinders	H
Lobe	M	Winders	C	Extruders (plastics)	M
Reciprocating, multi-cylinder, screw	M	Mills and drums (rotary type)		Extruders (rubber)	C
Reciprocating, single-cylinder	C	Ball mills (light)	C	Mixing mills	*
Conveyors		Ball and rod mills (heavy)	H	Refiners	H
Apron, scraper, screw	M	Cement kilns	H	Rubber mills, 2 in line	H
Belt, bucket, chain	C	Coal mills	H	Rubber mills, 3 in line	C
Live roll	*	Dryers and coolers	C	Sheeters	H
Shaker, reciprocating	H	Rotary kilns	H	Tubers	*
Cranes and hoists	*	Mining industry		Warming mills	C
Elevators		Cutter head drives	C	Pumps	
Bucket, heavy load	C	Crushers	H	Centrifugal	M
Bucket, uniform load	M	Screens and shakers	H	Reciprocating (multi-cylinder)	M
Escalators	M	Oil industry	*	Reciprocating (single-cylinder)	C
Freight lifts	M	Paper and pulp industry	*	Rotary (gear type, lobe, vane)	U
Man lifts	*	Agitators (chest and two shaft)	M	Screw pumps	M
Food industry		Debarking drums and barkers	H	Vacuum pumps	H
Beet slicer	M	Beaters and chippers	H	Sewage disposal equipment	
Crushers and mills	C	Calenders (antifriction bearings)	C	Aerators	C
Drying drums	M	Cutter	H	Collectors	M
Sugar cane crushers	M	Dryer cylinders (antifriction bearings)	C	Mixers	M
Generators	U	Filters (pressure and vacuum)	M	Thickeners	M
Lumber industry	*	Jordans	C	Vacuum filters	M
Machine tools	*	Line shafts	M	Wind turbines	*
Metal mills		Presses (bark, felt, size, suction)	C		
Draw bench, carriage and main drive	M	Pulpers	H		

Note: * refer to Santasalo

The values given in Table 3 are based on experience and are valid for applications in general. In the case of a special application or where the loading is not clear, it is recommended that the loads be measured. For applications not included in Table 3, please refer to Santasalo.

Nominal mechanical power ratings

Gear unit	Page
Helical gear units, horizontal LSS	
D1PSF 1 -stage helical gear units, horizontal LSS	2.02-03
D2P., 2C..N, 2TC..N 2 -stage helical gear units, horizontal LSS	2.04-05
D3P., 3C..N, 3TC..N 3 -stage helical gear units, horizontal LSS	2.06-07
D4P., 4C..N, 4TC..N 4 -stage helical gear units, horizontal LSS	2.08-09
D5P.. 5 -stage helical gear units, horizontal LSS	2.09
Bevel-helical gear units, horizontal LSS	
2KC..M, 2TKC..M 2 -stage bevel-helical gear units, horizontal LSS	2.10
D3R., 3KC..N, 3TKC..N, 3TKCV..N 3 -stage bevel-helical gear units, horizontal LSS	2.11
D4R.. 4 -stage bevel-helical gear units, horizontal LSS	2.12
D5R., 5KC..N, 5TKC..N 5 -stage bevel-helical gear units, horizontal LSS	2.13
Helical gear units, vertical LSS	
D2PV.. 2 -stage helical gear units, vertical LSS	2.14
D3PV.. 3 -stage helical gear units, vertical LSS	2.15
D4PV.. 4 -stage helical gear units, vertical LSS	2.15
Bevel-helical gear units, vertical LSS	
D3RV.. 3 -stage bevel-helical gear units, vertical LSS	2.16
D4RV.. 4 -stage bevel-helical gear units, vertical LSS	2.16

Power ratings:

The ratings P_{N1} are nominal, service factor $F_s = 1.0$.

Lubrication:

Splash lubrication is used, unless otherwise indicated. Pressure lubrication is highly recommended when the mechanical power rating P_{k1} is higher than 500 kW.

Cooling:

Additional cooling is required, when the mechanical power rating P_{k1} is higher than the thermal rating P_T .

1-stage helical gear units, horizontal LSS

Size	n ₁ min ⁻¹	Nominal mechanical power ratings P _{NI} in kW																Dimensions
		Splash lubrication and bath lubrication																
		Mineral oil, ISO VG 320, Oil temperature to = 80°C																
		Synthetic oil, ISO VG 320, Oil temperature to = 90°C																
D1PSF		Nominal ratio i _N																
		1.25	1.4	1.6	1.8	2	2.25	2.5	2.8	3.15	3.55	4	4.5	5	5.6	6.3	7.1	
20	1800	348	327	300	279	258	236	215	193	170+	150+	115+	92.4+	89.4+	71.6+	55.1+	40.1+	
	1500	293	276	252	235	217	199	180+	162+	143+	125+	95.8+	76.9+	74.5+	59.7+	45.9+	33.4+	
	1200	237	223	204	189+	175+	160+	145+	130+	115+	100+	76.6+	61.5+	59.5+	47.7+	36.7+	26.7+	
	1000	199+	187+	171+	159+	147+	134+	122+	109+	96.0+	83.3+	63.8+	51.2+	49.6+	39.7+	30.6+	22.3+	
30	1800	732	677	636	580	537	466	424	406	360	306	260	211+	202+	158+	119+	92.2+	
	1500	618	572	536	488	452	391	356	341	302	257+	217+	176+	168+	132+	98.8+	76.8+	
	1200	501	463	434	395	365	316	287+	274+	243+	207+	173+	141+	134+	105+	79.0+	61.4+	
	1000	422	389	364	331	306+	265+	241+	230+	204+	173+	144+	117+	112+	87.7+	65.8+	51.2+	
40	1800	1562	1463	1362	1260	1157	1052	1012	872	803	638	510	435	341	352+	278+	204+	
	1500	1320	1235	1149	1062	974	884	850	732	668	535	425	362+	284+	293+	231+	170+	
	1200	1071	1001	930	859	787	714	685	590	534	430+	339+	289+	227+	234+	184+	136+	
	1000	901	842	782	721	660	599	574+	494+	444+	360+	282+	241+	189+	194+	153+	114+	
50	1800	-	-	-	2536	2381	2286	2125	1918	1529	1249	1069	847	664	692	551	383+	
	1500	2323	2323	2283	2202	2067	1965	1771	1599	1274	1041	890	705	553	575+	458+	320+	
	1200	1858	1858	1858	1823	1717	1586	1417	1279	1018	832	711	563+	441+	459+	365+	256+	
	1000	1548	1548	1548	1548	1453	1322	1181	1066	848	692+	591+	468+	367+	381+	303+	213+	
60	1800	-	-	-	-	-	-	-	-	-	-	-	1560	1298	1289	1037	726	
	1500	-	-	-	-	-	-	-	-	-	-	-	1680	1299	1080	1072	862	
	1200	-	-	-	-	-	-	-	-	2027	1674	1342	1038	862	854+	687+	484+	
	1000	-	-	-	-	-	-	2190	1995	1687	1393	1117	863+	717+	710+	570+	404+	
70	1800	-	-	-	-	-	-	-	-	-	-	-	-	-	1654	1652	1150	
	1500	-	-	-	-	-	-	-	-	-	-	-	-	1744	1377	1373	958	
	1200	-	-	-	-	-	-	-	-	-	-	-	1671	1393	1099	1094	767+	
	1000	-	-	-	-	-	-	-	-	-	2012	1784	1391	1159	914+	908+	639+	
80	1800	-	-	-	-	-	-	-	-	-	-	-	-	-	-	-	-	
	1500	-	-	-	-	-	-	-	-	-	-	-	-	-	1902	2017	1403	
	1200	-	-	-	-	-	-	-	-	-	-	-	-	-	1519	1607	1122	
	1000	-	-	-	-	-	-	-	-	-	-	-	-	1708	1264	1334	935+	
90	1800	-	-	-	-	-	-	-	-	-	-	-	-	-	-	-	-	
	1500	-	-	-	-	-	-	-	-	-	-	-	-	-	-	-	-	
	1200	-	-	-	-	-	-	-	-	-	-	-	-	-	-	-	1463	
	1000	-	-	-	-	-	-	-	-	-	-	-	-	-	-	1700	1219	
100	1800	-	-	-	-	-	-	-	-	-	-	-	-	-	-	-	-	
	1500	-	-	-	-	-	-	-	-	-	-	-	-	-	-	-	-	
	1200	-	-	-	-	-	-	-	-	-	-	-	-	-	-	-	1919	
	1000	-	-	-	-	-	-	-	-	-	-	-	-	-	-	-	1600	

D1
D1PSF page 8.01-8.02

+) Bath lubrication is possible

2-stage helical gear units, horizontal LSS

Size	n ₁ min ⁻¹	Nominal mechanical power ratings P _{N1} in kW										
		Nominal ratio i _N										
2C../2TC..		6.3	7.1	8	9	10	11.2	12.5	14	16	18	20
140N	1800	84.2	77.1	70.8	65.8+	61.5+	56.6+	51.8+	46.3+	42.3+	36.9+	30.7+
	1500	74.1	67.9+	62.4+	58+	54.2+	49.8+	45.4+	38.7+	35.4+	31.1+	25.6+
	1200	63.4+	58+	53.3	49.3+	45.7+	41.9+	38.2+	31+	28.6+	25.2+	20.7+
	1000	55.8+	51+	46.5+	42.8+	39.7+	36.4+	33.1+	25.9+	23.8+	21.2+	17.3+
160N	1800	128	117	107	98.2	91.3	82.9	74.7	60.6+	56+	49.8+	41.5+
	1500	113	103	94+	86.5+	80.4+	72.9+	65.7+	50.6+	46.8+	41.7+	34.8+
	1200	96.7+	87.8+	80.4+	74+	67.9+	61.7+	54.3+	40.6+	37.6+	33.5+	28.1+
	1000	85.1+	77.3+	68.3+	63.8+	56.8+	53.5+	45.3+	33.9+	31.4+	27.9+	23.6+
180N	1800	187	173	160	146	132	125	116	101+	89.4+	79.8+	67.1+
	1500	164	152	141	128	111+	107+	101+	84+	74.7+	67.7+	56.5+
	1200	141	130+	119+	110+	89+	85.8+	81.4+	67.4+	60+	54.9+	45.7+
	1000	124+	115+	99.1+	95.9+	74.3+	71.7+	68+	56.3+	50.1+	45.9+	38.3+
200N	1800	288	271	248	225	209	187	171	152	134	113	96.1+
	1500	253	239	218	196	179	164	150+	128+	113+	94.3+	80.4+
	1200	216	204	187	158+	144+	135+	120+	103+	90.9+	76+	64.5+
	1000	181+	175+	156+	132+	120+	112+	100+	86.3+	76.3+	63.8+	53.9+
225N	1800	432	397	360	336	311	302	274	216	195	171	151
	1500	380	349	317	295	274	258	229	181	163	144+	126+
	1200	325	299	271	250	227+	207+	183+	145+	131+	116+	102+
	1000	286	261	230+	209+	190+	172+	153+	121+	110+	97.5+	85.2+
250N	1800	601	553	503	463	417	398	370	320	255	233	196
	1500	529	486	438	402	363	350	322	269	219	200	168
	1200	451	410	369	339	306	294	263	217+	182+	166+	140+
	1000	391	356	321	293+	261+	249+	220+	183+	156+	142+	120+

2C..N page 8.03, 2TC..N page 8.04



3-stage helical gear units, horizontal LSS

Size	n ₁ min ⁻¹	Nominal mechanical power rating P _{N1} in kW													
		Nominal ratio i _N													
D3PH.		20	22.5	25	28	31.5	35.5	40	45	50	56	63	71	80	90
100	1800	1947*	1742*	1588*	1478*	1336*	1186*	1077*	982*	897*	798*	695*	621*	540*	499*
	1500	1684*	1507*	1366*	1259*	1138*	1009*	918	833	761	665	579	517+	458+	426+
	1200	1408*	1241*	1120*	1032*	929	825+	750+	674+	612+	532+	470+	427+	378+	352+
	1000	1194*	1056*	950+	875+	788+	696+	626+	569+	521+	453+	402+	365+	324+	301+
110	1800	2375*	2131*	1931*	1762*	1608*	1438*	1299*	1180*	1073*	996*	901*	807*	731*	648*
	1500	2044*	1844*	1667*	1502*	1364*	1224*	1105*	1001*	911	845	764	672	615+	551+
	1200	1713*	1525*	1363*	1232*	1119*	1001*	904+	819+	734+	680+	615+	552+	505+	453+
	1000	1456*	1294*	1160*	1045*	949+	849+	760+	684+	622+	578+	523+	469+	429+	385+
120	1800	-	-	-	-	-	-	-	-	-	-	-	-	-	-
	1500	2689*	2495*	2336*	2084*	2025*	1827*	1651*	1502*	1364*	1233*	1118*	1004*	894*	799*
	1200	2241*	2074*	1923*	1718*	1652*	1490*	1351*	1229*	1111*	1005*	904+	800+	722+	654+
	1000	1910*	1789*	1659*	1493*	1403*	1265*	1143*	1040*	938+	836+	755+	679+	614+	555+
130	1800	-	-	-	-	-	-	-	-	-	-	-	-	-	-
	1500	2702*	2534*	2297*	2298*	2130*	1968*	1899*	1715*	1558*	1470*	1298*	1165*	1021*	935*
	1200	2255*	2115*	1932*	1930*	1789*	1652*	1557*	1406*	1273*	1202*	1062*	940+	820+	761+
	1000	1958*	1835*	1664*	1663*	1541*	1414*	1320*	1193*	1080*	1017*	881+	792+	698+	647+
140	1800	-	-	-	-	-	-	-	-	-	-	-	-	-	-
	1500	-	-	-	-	-	-	-	-	-	-	-	-	-	-
	1200	2803*	2561*	2379*	2197*	2015*	2013*	1956*	1734*	1570*	1378*	1251*	1131*	1026*	914+
	1000	2433*	2206*	2049*	1893*	1736*	1723*	1664*	1469*	1331*	1169*	1059*	940+	857+	777+
150	1800	-	-	-	-	-	-	-	-	-	-	-	-	-	-
	1500	-	-	-	-	-	-	-	-	-	-	-	-	-	-
	1200	3398*	3423*	3200*	2890*	2665*	2449*	2239*	2076*	1909*	1761*	1569*	1399*	1273*	1167*
	1000	2949*	2948*	2757*	2490*	2287*	2119*	1938*	1787*	1619*	1494*	1331*	1185*	1061*	972+
160	1800	-	-	-	-	-	-	-	-	-	-	-	-	-	-
	1500	-	-	-	-	-	-	-	-	-	-	-	-	-	-
	1200	4077*	3808*	3836*	3479*	3282*	3010*	2924*	2565*	2331*	2141*	1925*	1764*	1606*	1448*
	1000	3540*	3306*	3304*	2997*	2827*	2593*	2480*	2182*	1976*	1816*	1633*	1496*	1359*	1213*

D3PHF 100-160 page 8.15-16, D3PHT 100-160 page 8.17-18



*) Pressure lubrication is required

+) Bath lubrication is possible

2-stage bevel-helical gear units, horizontal LSS

Size	n ₁ min ⁻¹	Nominal mechanical power rating P _{N1} in kW														
		Nominal ratio i _N														
2KC../2TKC.		4.0	4.5	5.0	5.6	6.3	7.1	8.0	9.0	10	11.2	12.5	14	16	18	20
90M	1800	35.9	35	28.8+	27.3+	22.0+	20.3+	12.0+	11.6+	9.80+	8.81+	7.32+	4.83+	4.55+	3.70+	3.25+
	1500	31.6+	29.4+	25.1+	22.9+	18.4+	17.3+	9.98+	9.70+	8.17+	7.34+	6.11+	4.03+	3.99+	3.09+	2.72+
	1200	26.3+	23.7+	20.1+	18.7+	14.7+	13.9+	7.98+	7.76+	6.55+	5.88+	4.89+	3.23+	3.39+	2.49+	2.20+
	1000	22.0+	20.0+	16.8+	15.7+	12.3+	11.6+	6.65+	6.47+	5.46+	4.90+	4.09+	2.71+	2.97+	2.09+	1.85+
110M	1800	75.8	65.1	60.9	50.8	49.2+	38.6+	31.9+	27.9+	23.3+	19.9+	16.9+	14.2+	9.06+	9.06+	8.58+
	1500	66.5	54.4	53.6+	42.4+	41.9+	32.2+	26.6+	23.3+	19.5+	16.6+	14.1+	12.2+	7.97+	7.97+	7.22+
	1200	56.6+	43.6+	45.3+	34.0+	34.0+	25.8+	21.3+	18.6+	15.6+	13.3+	11.3+	9.92+	6.82+	6.82+	5.85+
	1000	48.3+	36.4+	38.1+	28.4+	28.3+	21.5+	17.7+	15.5+	13.0+	11.1+	9.44+	8.31+	5.98+	6.00+	4.92+
140M	1800	144	141	119	111	98.5	84.2	79.8+	69.8+	57.8+	46.6+	40.9+	30.8+	23.8+	23.7+	17.2+
	1500	127	118	105	92.9	82.3+	71.7+	66.6+	59.8+	49.5+	39.2+	35.0+	25.7+	20.9+	19.8+	14.4+
	1200	109	95.1	88.6+	75.9+	66.0+	59.3+	53.4+	49.4+	41.0+	31.6+	29.0+	20.6+	17.1+	16.0+	11.7+
	1000	95.2+	80.1+	74.0+	65.1+	55.0+	50.8+	44.6+	41.4+	35.1+	26.6+	24.9+	17.2+	14.3+	13.4+	9.81+
180M	1800	251	257	237	235	181	177	151	144	122	107+	86.0+	68.9+	52.7+	53.3+	43.9+
	1500	221	227	208	207	160	156	133+	127+	104+	89.5+	73.2+	59.0+	44.2+	44.8+	38.7+
	1200	189	194	177	172	136+	129+	113+	105+	84.3+	72.1+	58.6+	48.8+	35.7+	36.1+	32.0+
	1000	166	171	155	143	120+	107+	95.4+	87.7+	70.3+	60.1+	49.0+	41.8+	30.0+	30.3+	26.9+
225M	1800	631*	588*	527	465	402	351	323	293	239	207	193	153	105+	106+	86.6+
	1500	552	492	462	389	337	299	270	250	205	173+	165+	129+	88.0+	89.0+	72.8+
	1200	469	396	371	317	271	247	217+	203+	169+	139+	136+	104+	71.1+	71.9+	58.7+
	1000	396	333	310	271	226+	207+	181+	169+	145+	116+	116+	86.8+	59.7+	60.3+	49.2+
250M	1800	787*	791*	647*	638*	493	493	415	415	371	272	272	251	130	130	130
	1500	689*	679*	568	533	434	434	365	365	310	228	227	213	115+	115+	115+
	1200	585	546	470	434	357	357	296	296	249	183+	183+	170+	98.1+	98.1+	98.1+
	1000	492	459	391	372	298	298	247+	247+	207+	152+	152+	143+	86.2+	86.4+	86.4+
280M	1800	1044*	1053*	863*	863*	699	691	564	564	555	377	377	349	215	215	172
	1500	914*	921*	760	760	588	587	496	496	475	315	315	299	183+	186+	144+
	1200	777	781	647	629	474	473	423	408	393	253+	253+	243+	148+	149+	116+
	1000	680	658	567	539	396	396	353+	341+	337+	211+	211+	204+	124+	125+	97.5
315M	1800	-	-	-	-	-	-	771*	771*	740*	586*	511	488	343	347	251
	1500	1499*	1321*	1054*	1004*	944*	726*	646*	645*	633*	502*	449	418	287	291	210
	1200	1205*	1061*	852	818	770	585	519	519	518	416	361	345	231+	234+	170+
	1000	1014	893	714	700	659	490	434	434	433	357	302+	295+	194+	196+	142+
355M	1800	-	-	-	-	-	-	-	-	-	-	640	640	511	402	395
	1500	2056*	1927*	1607*	1570*	1289*	1193*	840*	840*	837*	713*	536	535	426	337	329
	1200	1645*	1547*	1286	1280	1051	961	676	675	675	570	430	430	341	271+	263+
	1000	1371*	1300*	1072	1072	899	805	565	565	564	475	360+	359+	284+	227+	219+
400M	1800	-	-	-	-	-	-	-	-	-	-	890*	889*	664*	571*	512*
	1500	2819*	2606*	2343*	2137*	1848*	1664*	1320*	1320*	1221*	969*	745	744	553	478	427
	1200	2290*	2097*	1874*	1718*	1507*	1340	1062	1061	979	776	598	598	443	385	342
	1000	1928*	1755*	1562	1436	1289	1120	888	887	818	646	500	499	369	323+	285+

2KC..M page 9.01-02, 2TKC..M page 9.03-04

*) Pressure lubrication is required

+) Bath lubrication is possible

4-stage bevel-helical gear units, horizontal LSS

Size	n_{\min}^{-1}	Nominal mechanical power ratings P_{N1} in kW											
		Nominal ratio i_N											
D4R..		90	100	112	125	140	160	180	200	225	250	280	315
50	1800	94.7+	89.6+	82.8+	72.3+	64.5+	57.2+	49.3+	44.8+	40.6+	36.2+	32.0+	28.6+
	1500	81.7+	77.1+	68.2+	58.8+	52.4+	46.8+	42.0+	38.4+	33.8+	30.2+	26.7+	23.9+
	1200	65.3+	60.6+	52.9+	46.2+	42.4+	38.7+	34.8+	31.3+	27.4+	24.2+	21.4+	19.1+
	1000	53.1+	49.2+	44.2+	39.6+	36.4+	32.2+	29.0+	26.1+	23.3+	20.2+	17.8+	15.9+
60	1800	137+	124+	116+	114+	87.7+	88.7+	82.2+	71.1+	63.3+	57.0+	45.6+	40.7+
	1500	118+	104+	96.7+	95.0+	73.1+	74.0+	68.5+	59.3+	52.8+	47.6+	38.9+	34.1+
	1200	98.4+	82.9+	77.4+	76.1+	58.6+	59.2+	54.9+	47.5+	42.3+	38.1+	31.1+	27.2+
	1000	82.6+	69.1+	64.6+	63.5+	48.8+	49.4+	45.8+	40.3+	35.3+	31.8+	25.9+	22.7+
70	1800	212+	188+	169+	148+	135+	118+	106+	93.8+	83.9+	79.7+	70.6+	61.8+
	1500	177+	157+	141+	123+	113+	98.7+	88.3+	78.2+	70.0+	65.4+	57.8+	50.6+
	1200	142+	126+	113+	98.7+	90.2+	79.1+	70.7+	62.7+	56.1+	51.1+	45.2+	39.5+
	1000	118+	105+	94.4+	82.4+	75.3+	66.0+	59.0+	52.3+	46.3+	41.8+	36.9+	32.2+
80	1800	253+	239+	216+	194+	176+	155+	144+	128+	113+	91.5+	85.3+	75.8+
	1500	211+	203+	184+	165+	150+	129+	118+	108+	95.0+	76.3+	71.1+	63.1+
	1200	169+	167+	151+	134+	118+	104+	94.5+	85.1+	74.5+	61.1+	56.8+	50.5+
	1000	141+	140+	124+	111+	98.8+	86.6+	77.5+	69.7+	61.0+	51.0+	47.4+	42.1+
90	1800	369	332+	281+	281+	250+	220+	194+	179+	161+	127+	127+	109+
	1500	318+	280+	240+	241+	209+	183+	162+	150+	134+	106+	106+	91.1+
	1200	267+	225+	201+	192+	167+	147+	130+	120+	107+	84.6+	84.8+	73.0+
	1000	223+	188+	169+	158+	139+	122+	108+	100+	89.6+	70.5+	70.7+	60.9+
100	1800	526	463	414	380	342+	312+	279+	248+	222+	193+	171+	154+
	1500	439	387+	346+	317+	285+	260+	233+	207+	185+	161+	143+	129+
	1200	352+	310+	277+	254+	229+	209+	186+	166+	148+	128+	114+	103+
	1000	294+	259+	231+	212+	191+	174+	155+	138+	123+	107+	95.3+	86.0+
110	1800	588	592	530	488	445	403	367+	328+	290+	263+	234+	191+
	1500	511	504	449	416+	379+	344+	313+	274+	242+	219+	195+	159+
	1200	424+	413+	370+	342+	312+	283+	255+	219+	194+	175+	156+	128+
	1000	368+	352+	315+	292+	265+	236+	210+	183+	162+	146+	131+	107+
120	1800	985*	869*	801*	673*	594*	567*	505*	465*	406+	362+	323+	288+
	1500	837*	733*	675	562	496	473	421	388+	339+	299+	270+	241+
	1200	674	587+	540+	450+	397+	379+	337+	308+	271+	242+	216+	193+
	1000	562+	490+	451+	376+	332+	314+	281+	259+	226+	202+	180+	161+
130	1800	-	-	949*	840*	746*	678*	623*	577*	502	423+	359+	330+
	1500	948*	850*	804*	705*	619*	558+	508+	470+	408+	343+	303+	283+
	1200	779	686	647+	556+	482+	434+	394+	365+	322+	284+	252+	235+
	1000	650	565+	533+	452+	392+	352+	323+	307+	276+	243+	215+	198+
140	1800	-	-	-	-	-	-	-	-	600*	537*	474*	419+
	1500	-	-	957*	865*	769*	690*	637*	549*	490+	439+	396+	353+
	1200	942	836	767	702	613+	544+	498+	439+	393+	361+	317+	283+
	1000	798+	698+	640+	581+	501+	444+	411+	366+	337+	311+	264+	236+
150	1800	-	-	-	-	-	-	-	-	667*	594*	536*	471*
	1500	-	-	-	-	-	-	-	-	545	484	441	401+
	1200	1143*	1021*	911	805	696	628+	562+	488+	432+	396+	366+	333+
	1000	936	837+	746+	658+	568+	512+	458+	411+	371+	340+	315+	286+
160	1800	-	-	-	-	-	-	-	-	782*	711*	624*	549*
	1500	-	-	-	-	-	-	-	-	640*	581*	510*	463*
	1200	1306*	1176*	1066*	943*	815*	713*	653*	573*	500+	467+	424+	385+
	1000	1072*	965	874	772	666+	583+	534+	477+	430+	401+	364+	331+

D4R.. 50-90 page 9.10-11, D4RSF, D4RHF page 9.12-13, D4RHT page 9.14-15, D4RUHT page 9.16-17



*) Pressure lubrication is required

+) Bath lubrication is possible

2-stage helical gear units, vertical LSS

Size	n_{\min}^{-1}	Nominal mechanical power ratings P_{N1} in kW									
		Nominal ratio i_N									
D2PV..		6.3	7.1	8	9	10	11.2	12.5	14	16	18
10	1800	170*	155*	140*	129+	116+	106+	94.3+	86.8+	79.3+	63.9+
	1500	147*	135+	121+	111+	98.6+	89.9+	80.0+	73.9+	67.4+	53.2+
	1200	123+	112+	99.5+	91.0+	80.7+	73.5+	65.6+	60.2+	54.9+	42.6+
	1000	105+	94.9+	84.7+	77.0+	67.5+	62.5+	55.6+	50.5+	45.8+	35.5+
20	1800	231*	179*	158*	149+	142+	140+	130+	115+	101+	88.7+
	1500	194*	150+	133+	125+	119+	120+	110+	95.8+	84.4+	74.1+
	1200	155+	121+	107+	100+	95.6+	97.3+	88.1+	76.6+	67.5+	59.5+
	1000	129+	102+	89.5+	83.8+	80.0+	81.0+	73.4+	63.9+	56.3+	49.7+
30	1800	438*	404*	363*	333*	305*	280*	249*	230+	206+	179+
	1500	365*	347*	313*	286*	262+	242+	214+	194+	174+	149+
	1200	292*	291+	261+	239+	216+	198+	173+	156+	139+	119+
	1000	243+	243+	222+	202+	182+	165+	144+	130+	116+	99.0+
40	1800	571*	571*	533*	483*	435*	387*	356*	322*	279+	239+
	1500	476*	476*	463*	417*	375*	332*	299+	268+	234+	199+
	1200	381*	381*	381*	340+	309+	265+	239+	214+	188+	159+
	1000	317+	317+	317+	285+	261+	221+	199+	179+	157+	132+
50	1800	955*	873*	789*	725*	664*	596*	547*	499*	448*	393*
	1500	828*	758*	681*	626*	573*	515*	470*	423+	382+	329+
	1200	688*	633*	569*	523*	477*	423+	383+	346+	306+	264+
	1000	598*	547*	491*	447+	404+	358+	325+	293+	255+	221+
60	1800	1648*	1472*	1352*	1238*	1099*	1003*	921*	845*	744*	664*
	1500	1382*	1269*	1173*	1068*	945*	873*	799*	729*	619*	553*
	1200	1106*	1061*	975*	894*	789*	727*	658+	592+	494+	442+
	1000	921*	915*	846*	772*	676+	614+	552+	493+	412+	368+
70	1800	2010*	1811*	1615*	1463*	1339*	1213*	1109*	995*	907*	841*
	1500	1722*	1552*	1395*	1263*	1157*	1054*	963*	859*	783*	720*
	1200	1439*	1297*	1166*	1062*	972*	880*	804*	709*	635*	583+
	1000	1243*	1120*	1012*	916*	839*	757*	679*	597+	537+	493+
80	1800	2527*	2267*	2015*	1818*	1654*	1514*	1367*	1255*	1134*	1038*
	1500	2179*	1943*	1740*	1570*	1429*	1315*	1187*	1083*	973*	893*
	1200	1809*	1624*	1454*	1320*	1200*	1098*	991*	901*	800*	718+
	1000	1572*	1411*	1262*	1139*	1036*	948*	840*	758+	679+	600+

D2PV.. page 10.02-05



*) Pressure lubrication is required

+) Bath lubrication is possible

3,4-stage bevel-helical gear units, vertical LSS

Size	n min ⁻¹	Nominal mechanical power ratings PN1 in kW															
		Nominal ratio i_N															
D3RV..		14	16	18	20	22.5	25	28	31.5	35.5	40	45	50	56	63	71	80
30	1800	176*	176*	164*	156*	146*	128*	112+	97.7+	91.2+	80.8+	71.0+	64.1+	55.8+	48.8+	42.8+	33.2+
	1500	152+	152+	142+	134+	122+	107+	93.6+	81.5+	76.0+	67.4+	59.1+	53.5+	46.5+	40.7+	35.6+	27.7+
	1200	127+	127+	118+	110+	98.0+	85.3+	75.0+	65.2+	60.9+	54.0+	47.2+	42.9+	37.2+	33.1+	28.5+	22.9+
	1000	110+	110+	102+	91.9+	81.7+	71.1+	62.5+	54.4+	50.8+	45.1+	39.3+	38.6+	31.0+	28.4+	23.7+	19.7+
40	1800	223*	223*	213*	202*	189*	187*	147+	143+	133+	111+	99.8+	77.1+	77.1+	66.9+	59.4+	39.5+
	1500	193+	193+	183+	174+	162+	156+	123+	119+	111+	92.5+	83.2+	64.2+	64.2+	55.8+	49.6+	32.9+
	1200	159+	159+	154+	145+	130+	125+	98.0+	95.2+	88.9+	73.9+	66.7+	51.4+	51.4+	44.6+	40.2+	26.3+
	1000	132+	132+	132+	126+	109+	104+	81.7+	79.4+	74.2+	61.5+	55.6+	42.8+	42.8+	37.2+	34.5+	21.9+
50	1800	456*	456*	418*	376*	307*	299*	269*	249+	221+	194+	148+	148+	130+	113+	95.1+	84.4+
	1500	397*	397*	354*	317*	256+	253+	226+	207+	184+	162+	123+	123+	109+	94.5+	79.4+	71.5+
	1200	326+	326+	290+	253+	205+	202+	181+	166+	147+	129+	98.4+	98.4+	86.8+	75.6+	65.6+	59.3+
	1000	272+	272+	244+	211+	171+	169+	151+	138+	123+	108+	82.0+	81.9+	72.3+	63.0+	56.3+	50.6+
60	1800	611*	611*	602*	607*	546*	482*	391*	372*	342*	304+	278+	223+	194+	167+	142+	133+
	1500	509*	509*	509*	505*	455*	402*	326+	310+	285+	253+	232+	186+	161+	139+	118+	112+
	1200	407+	407+	407+	404+	363+	321+	260+	248+	228+	202+	186+	149+	129+	111+	94.4+	93.1+
	1000	339+	339+	339+	336+	303+	268+	217+	207+	190+	169+	147+	124+	108+	92.9+	78.5+	78.5+
70	1800	-	-	-	-	690*	627*	573*	525*	458*	413*	363+	333+	282+	255+	225+	198+
	1500	728*	728*	715*	650*	586*	524*	479*	441+	385+	349+	302+	279+	235+	213+	188+	167+
	1200	583*	583*	572*	527*	470*	419+	383+	353+	314+	285+	242+	224+	188+	170+	150+	137+
	1000	485+	485+	476+	447+	391+	350+	319+	294+	262+	238+	202+	191+	157+	142+	125+	114+
80	1800	-	-	-	-	-	778*	672*	617*	567*	520*	473*	367*	311+	311+	282+	245+
	1500	774*	774*	775*	756*	742*	654*	563*	514*	473+	438+	396+	306+	260+	260+	235+	204+
	1200	651*	651*	634*	605*	605*	523*	450+	411+	378+	356+	320+	245+	208+	208+	188+	162+
	1000	555+	555+	528+	504+	504+	436+	375+	343+	315+	297+	268+	204+	173+	173+	157+	135+
90	1800	-	-	-	-	-	-	-	-	-	-	-	490*	398+	398+	361+	268+
	1500	1287*	1287*	1287*	1208*	1039*	940*	783*	726*	668*	505*	426*	408+	331+	331+	300+	222+
	1200	1030*	1030*	1030*	991*	831*	751*	626+	581+	534+	404+	341+	327+	265+	265+	239+	177+
	1000	858*	858*	858*	837*	692*	626+	522+	484+	445+	336+	284+	272+	221+	221+	199+	147+

D3RV.. page 11.02-05



Size	n min ⁻¹	Nominal mechanical power ratings P _{N1} in kW											
		Nominal ratio i_N											
D4RV..		90	100	112	125	140	160	180	200	225	250	280	315
50	1800	97.7+	90+	80.5+	70.8+	63.9+	57.5+	50.6+	45.6+	40.7+	37.5+	32.9+	29.5+
	1500	81.5+	75.5+	67.2+	59.0+	53.3+	48.0+	42.2+	38.0+	34.0+	31.2+	27.4+	24.6+
	1200	65.3+	60.5+	53.8+	47.3+	42.7+	38.4+	33.8+	30.4+	27.2+	25.0+	21.9+	19.7+
	1000	54.5+	50.5+	44.9+	39.4+	35.6+	32.1+	28.2+	25.4+	22.7+	20.8+	18.3+	16.4+
60	1800	145+	114+	107+	107+	85.2+	85.2+	77.1+	72.1+	62.4+	56.2+	46.3+	40.6+
	1500	124+	95.2+	88.8+	88.8+	71.0+	71.0+	64.2+	60.1+	52.1+	46.9+	38.6+	33.8+
	1200	100+	76.1+	71.1+	71.1+	56.8+	56.8+	51.4+	48.1+	41.7+	37.5+	30.9+	27.1+
	1000	83.5+	63.4+	59.2+	59.2+	47.3+	47.3+	42.8+	40.2+	34.8+	31.3+	25.8+	22.6+
70	1800	207+	184+	166+	144+	132+	116+	103+	91.7+	82.0+	79.6+	71.1+	62.3+
	1500	173+	153+	138+	120+	110+	96.5+	86.3+	76.5+	68.4+	65.9+	58.2+	50.9+
	1200	139+	123+	111+	96.5+	88.2+	77.3+	69.1+	61.2+	54.8+	51.5+	45.5+	39.8+
	1000	116+	103+	92.3+	80.5+	73.6+	64.5+	57.6+	51.1+	45.7+	42.1+	37.2+	32.5+
80	1800	267+	241+	218+	196+	177+	131+	146+	129+	115+	93.6+	83.3+	74.1+
	1500	222+	205+	185+	167+	151+	109+	122+	108+	95.7+	78.0+	69.4+	61.7+
	1200	178+	168+	152+	137+	122+	87.1+	95.5+	85.8+	75.1+	62.5+	55.5+	49.4+
	1000	149+	143+	128+	113+	99.7+	72.6+	78.2+	70.3+	61.5+	52.2+	46.3+	41.2+
90	1800	392*	334+	286+	286+	254+	226+	200+	175+	158+	126+	124+	111+
	1500	329+	280+	238+	238+	212+	189+	167+	147+	131+	105+	104+	92.3+
	1200	263+	225+	191+	191+	170+	151+	134+	118+	105+	83.8+	83.1+	73.9+
	1000	219+	188+	159+	159+	141+	126+	112+	98.2+	87.8+	69.8+	69.3+	61.6+

D4RV.. page 11.06-09



*) Pressure lubrication is required

+) Bath lubrication is possible

Nominal output torque

Size	Nominal output torque M_{N2} in kNm ($n_1=1000$ 1/min)															
	Nominal ratio i_N															
	1.25	1.14	1.6	1.8	2	2.25	2.5	2.8	3.15	3.55	4	4.5	5	5.6	6.3	7.1
20	2.36	2.45	2.57	2.65	2.72	2.79	2.84	2.88	2.9	2.76	2.43	2.17	2.35	2.1	1.82	1.5
30	4.89	5.14	5.32	5.54	5.69	5.64	5.75	6.03	6.06	5.84	5.42	4.88	5.21	4.6	3.93	3.43
40	10.7	11.2	11.6	12	12.4	12.8	13.5	13.1	13.2	11.9	10.7	9.99	8.79	10.1	8.96	7.65
50	18.3	20.2	23.6	26.2	27.8	27.8	27.8	27.8	25.7	23.6	22	19.6	17.3	20.2	18	14.4
60	32.3	36.6	41.5	45.4	48.4	50.3	52.2	52.7	49.6	45.9	41.5	36.5	33.4	37.5	34	26.9
70	41.2	45.7	52.7	58.9	66.9	67.1	67.1	67.1	67.1	67.1	67.1	59.6	53.9	47.8	54.9	44.4
80	52.3	59.3	64.6	77.1	80.7	90.6	94.1	94.6	94.6	94.6	94.6	85.6	78.6	66.4	78.8	64.1
90	78	85.9	92.7	98	103	110	116	119	124	128	123	110	99.9	114	102	80.9
100	109	117	128	135	144	152	158	166	168	168	168	154	134	120	138	108
110	144	151	159	176	186	196	200	207	214	214	214	214	209	179	163	126
120	176	189	204	213	224	232	241	250	259	266	266	250	250	237	196	158
130	232	236	256	265	279	288	295	304	313	327	338	300	308	292	239	196

Size	Nominal output torque M_{N2} in kNm ($n_1=1000$ 1/min)										
	Nominal ratio i_N										
	6.3	7.1	8	9	10	11.2	12.5	14	16	18	
D2P...											
50	35.1	35.7	36.4	36.8	37	37.3	37.6	38	38.6	38.7	
60	59	60.3	61.4	62.8	63.7	63.8	64.3	65.1	61.7	61.7	
70	70	71.3	73.3	74.7	76	77.4	77.9	78.2	78.8	79.3	
80	90.1	91.3	94	95.8	97.7	99.5	99.9	101	101	103	
90	129	132	134	138	141	143	143	148	149	147	
D2PS...	5.6	6.3	7.1	8	9	10	11.2	12.5	14	16	18
100	165	172	177	181	187	192	197	203	207	217	193
110	206	216	221	227	234	239	247	252	258	266	277
120	291	303	316	326	333	344	352	363	372	381	396
130	324	345	361	375	387	397	407	421	431	440	452
140	399	420	440	458	473	487	502	514	527	540	552
150	488	509	532	555	573	587	610	624	640	659	673
160	606	634	663	684	701	724	746	764	783	804	814
D2PH...		6.3	7.1	8	9	10	11.2	12.5	14	16	18
100		172	177	181	187	192	197	203	207	217	193
110		216	221	227	234	239	247	252	258	266	277

Nominal output torque

Size	Nominal output torque M_{N2} in kNm ($n_1=1000$ 1/min)													
	Nominal ratio i_N													
D3P...	20	22.5	25	28	31.5	35.5	40	45	50	56	63	71	80	90
50	40.4	40.6	40.6	40.7	40.7	40.7	40.6	40	39.2	38.6	37.9	38.3	40.2	40.9
60	61.1	62.3	62.6	62.7	62.8	62.8	63.3	64.3	65.5	65.7	64.5	63.6	65.8	66.9
70	82	82.5	83.4	84.2	84.8	85.7	86.7	87.6	88.4	89.1	87.4	85.9	88.5	89.8
80	106	108	108	109	110	111	112	113	114	115	114	114	114	119
90	153	155	157	158	157	159	161	162	161	155	157	160	158	161
D3PS...	20	22.5	25	28	31.5	35.5	40	45	50	56	63	71	80	90
100	212	215	219	220	223	225	224	228	231	230	235	239	244	247
110	266	269	275	279	281	285	286	288	291	304	309	314	317	323
120N	365	375	389	394	412	416	420	425	430	425	420	414	408	402
130	445	447	453	460	466	471	477	483	489	502	492	484	473	467
140	495	511	523	536	547	590	597	609	618	627	630	622	614	605
150	591	618	632	652	665	682	700	708	700	708	697	686	677	669
160	778	796	827	837	844	847	841	821	812	814	803	794	785	774
D3PH...	20	22.5	25	28	31.5	35.5	40	45	50	56	63	71	80	90
100	212	215	219	220	223	225	224	228	231	230	235	239	243	246
110	266	269	275	279	281	285	286	288	291	304	309	314	317	323
120	351	362	375	390	412	416	420	425	429	428	431	436	442	448
130	365	379	390	434	449	457	477	483	489	503	504	511	519	524
140	448	462	476	489	502	560	597	609	618	627	632	628	632	642
150	526	603	626	645	665	686	704	723	733	763	776	785	780	784
160	654	674	756	785	808	830	883	898	911	938	951	961	968	972

Size	Nominal output torque M_{N2} in kNm ($n_1=1000$ 1/min)													
	Nominal ratio i_N													
D4P...	100	112	125	140	160	180	200	225	250	280	315	355	400	
50	41.6	42.1	43.1	43.8	43.6	46.8	46.4	45.8	45.2	45.4	46	46	42.5	
60	64.8	67.9	73.8	71.9	63.8	71.1	67.3	72.3	71.8	57	63.5	65.7	65	
70	96.4	95.2	95.6	98.3	97.3	96	95	93.7	92.6	91.3	92.6	91.9	84.8	
80	128	128	127	124	127	126	124	122	121	119	121	119	119	
90	171	162	165	175	161	180	182	180	175	173	180	178	161	
D4PS...	100	112	125	140	160	180	200	225	250	280	315	355	400	
100	258	266	270	272	270	269	267	265	263	247	248	248	250	
110	327	334	340	344	342	340	338	335	333	335	336	336	336	
120	421	427	448	442	437	442	450	454	454	451	451	451	452	
130	536	529	522	515	507	505	514	523	533	554	557	557	558	
140	555	570	587	645	657	650	665	678	714	709	705	682	694	
150	721	735	742	734	724	733	746	759	774	790	806	821	840	
160	887	878	869	859	861	851	856	873	895	910	928	948	965	
D4PH...	100	112	125	140	160	180	200	225	250	280	315	355	400	
100	241	239	237	235	232	231	229	226	224	234	236	242	249	
110	304	303	301	298	296	293	290	287	283	296	298	303	310	
120	427	389	418	414	409	403	398	393	387	401	396	403	411	
130	511	507	503	498	487	491	486	480	476	490	485	486	501	
140	555	567	583	611	606	600	596	591	611	604	598	597	608	
150	721	734	757	751	746	778	771	764	755	746	739	731	743	
160	921	937	947	939	968	962	952	942	929	920	912	903	903	

Nominal output torque

Size	Nominal output torque M_{N2} in kNm ($n_1=1000$ 1/min)												
	Nominal ratio i_N												
D5P...	450	500	560	630	710	800	900	1000	1120	1250	1400	1600	1800
100	245	251	256	261	266	273	278	281	237	249	251	249	249
110	311	316	324	331	338	344	352	346	348	348	350	316	316
120	410	419	427	435	445	454	463	480	491	495	480	456	458
130	498	508	518	528	542	552	565	556	557	607	609	603	606
140	609	621	633	645	661	663	709	724	738	753	747	678	681
150	740	755	769	787	801	790	796	873	894	913	913	818	822
160	905	922	946	963	985	990	989	1062	1076	1088	1099	1111	1122

Size	Nominal output torque M_{N2} in kNm ($n_1=1000$ 1/min)															
	Nominal ratio i_N															
D3R...	14	16	18	20	22.5	25	28	31.5	35.5	40	45	50	56	63	71	80
50	34.1	38.5	39.9	36.8	35.9	39.9	40.8	40.8	40.8	38.9	35	37.5	38.6	38.4	34.8	35.5
60	44	49.7	55.1	58.7	58.8	58.8	58.8	58.8	58.9	58.9	59.2	60.2	59.3	57.2	50.1	55.3
70	62.3	70	78	81.4	82.3	83.9	84.4	85.3	85.5	86.4	87.2	89.1	89	89.5	85.7	81.4
80	72.8	82.6	93.5	105	107	108	108	110	111	110	111	106	102	108	110	96.9
90	98.6	112	118	125	142	146	149	149	149	140	134	139	130	143	130	109
95	128	141	157	179	197	206	197	197	171	183	169	181	168	182	195	169

Size	Nominal output torque M_{N2} in kNm ($n_1=1000$ 1/min)												
	Nominal ratio i_N												
D4R...	90	100	112	125	140	160	180	200	225	250	280	315	
50	42.2	42.9	43.4	44.3	45.1	44.3	45.5	45.5	45.5	44.8	44.9	44.9	
60	67.8	63	63	69.9	59.6	68.1	70.1	69	69.6	69.6	65.3	65.3	
70	93.4	93.5	93.5	93.6	93.6	93.8	93.8	93.9	93	94.8	93.6	92.2	
80	114	129	127	127	127	124	125	127	125	118	119	119	
90	179	169	168	174	172	169	169	179	179	159	180	174	
100	233	233	233	233	233	245	245	245	250	250	250	245	
110	312	332	338	342	345	344	342	335	335	336	336	311	
120	451	452	452	420	420	447	450	450	451	451	451	452	
130	542	534	531	521	512	506	504	523	534	547	557	557	
140	669	651	652	689	679	671	673	670	700	712	678	678	
150	769	761	753	744	733	726	733	747	762	776	788	804	
160	893	886	878	869	857	846	839	843	861	888	906	924	

Size	Nominal output torque M_{N2} in kNm ($n_1=1000$ 1/min)															
	Nominal ratio i_N															
D5R...	355	400	450	500	560	630	710	800	900	1000	1120	1250	1400	1600	1800	
50	43	45.9	45.9	44.8	44.2	46.3	47	47.1	47.6	47.7	47.7	47.8	47.3	46.5	42.9	
60	70	70.1	70.1	70.2	62.5	69.5	71.8	72.6	73.2	73.2	73.2	73.3	73.4	73.4	65.7	
70	94.5	94.6	94.7	94.7	94.7	95	96.7	108	108	108	108	108	108	108	85.6	
80	117	128	130	132	134	130	130	139	140	130	134	140	140	119	120	
90	186	186	161	180	172	181	174	171	171	174	171	181	176	162	162	
100	235	239	245	251	254	259	264	273	278	237	249	249	251	249	249	
110	297	305	311	317	323	330	336	344	352	346	348	348	350	316	316	
120	395	402	411	420	427	435	444	453	462	480	491	495	480	456	458	
130	477	487	498	508	518	529	540	552	564	556	557	609	609	603	606	
140	585	596	608	619	632	646	662	676	704	719	736	754	747	678	681	
150	731	740	756	771	785	801	815	833	852	872	893	913	913	818	822	
160	873	891	913	931	944	960	983	994	987	1059	1074	1087	1100	1112	1124	

Nominal output torque

Size	Nominal output torque M_{N2} in kNm ($n_1=1000$ 1/min)									
	Nominal ratio i_N									
D2PV...	6.3	7.1	8	9	10	11.2	12.5	14	16	18
10	6.16	6.21	6.29	6.33	6.3	6.46	6.52	6.6	6.61	5.81
20	7.42	6.5	6.5	6.74	7.37	8.5	8.51	8.22	8.23	8.02
30	14.2	15.8	16.5	16.6	16.6	16.9	16.9	16.9	16.9	16.1
40	18.5	20.8	23	23.2	24.3	23.6	23.6	23.6	23.4	22.2
50	34.8	35.4	36.3	36.5	36.8	37.1	37.4	37.7	37.5	36.6
60	52.9	60.2	61.2	62.4	63.2	63.6	63.6	63.6	59.5	59.6
70	70.8	72	74.1	75.4	76.7	78.1	78.1	78.8	79.4	79.9
80	91.7	92.9	95	96.7	98.6	100	101	101	103	100

Size	Nominal output torque M_{N2} in kNm ($n_1=1000$ 1/min)													
	Nominal ratio i_N													
D3PV...	20	22.5	25	28	31.5	35.5	40	45	50	56	63	71	80	90
10	6.87	5.78	5.61	7.14	7.15	6.08	6.11	6.12	6.74	6.54	6.79	6.9	6.08	6.19
20	7.85	7.9	7.93	7.7	8.14	8.15	8.16	8.23	7.95	8.09	8.27	8.27	8.02	7.28
30	16	16.5	16.5	16.5	16.6	16.1	16.2	16.3	16.6	16.9	17.2	17.5	15.3	15.6
40	21.8	20.8	20.8	21.6	23.3	21.6	22.6	22.7	23.2	23.6	23.7	22.5	19	23.5
50	39.4	39.3	39.3	39.4	39.4	39.5	39.8	40.4	41.2	40.7	38.2	38.2	39.3	22.3
60	52.7	54.7	48	60.5	60.5	60.6	61	62	63.2	62.9	58.8	58.9	62.3	56.9
70	82.8	83.2	84.2	84.9	85.6	86.4	87.3	66.8	89.5	90.3	91.2	90.5	92.1	91
80	107	108	109	110	111	112	113	114	115	61.9	114	119	110	111
90	155	151	157	159	158	161	163	162	158	151	154	156	98	147
100	227	233	240	243	245	248	249	251	249	252	246	241	234	231
110	292	301	331	334	337	340	345	349	347	338	343	347	352	357
120	338	350	357	369	406	410	414	420	420	427	430	436	443	450

Size	Nominal output torque M_{N2} in kNm ($n_1=1000$ 1/min)													
	Nominal ratio i_N													
D4PV...	100	112	125	140	160	180	200	225	250	280	315	355	400	
50	38.7	40	40.9	39.3	39.3	46.5	46.1	45.6	44.7	43.9	45.9	46	42.2	
60	59.8	61.3	68	63	57.4	63.7	60.7	64.2	63.5	47	58	58.6	62.5	
70	99.2	94.3	97.1	96.1	96.2	96.3	95.9	94.6	93.5	92.2	93.3	92.6	82.9	
80	129	132	124	116	128	125	125	123	118	114	122	120	116	
90	160	152	151	173	150	174	175	175	164	167	178	178	157	
100	216	234	238	242	246	251	254	251	249	257	257	263	271	
110	340	360	355	351	348	342	337	332	328	337	332	335	342	
120	441	436	434	431	427	423	419	415	410	418	414	417	429	

Maximum torque M_{k2max} is $2 \times M_{N2}$

Size	Nominal output torque M_{N2} in kNm ($n_1=1000$ 1/min)															
	Nominal ratio i_N															
D3RV...	14	16	18	20	22.5	25	28	31.5	35.5	40	45	50	56	63	71	80
30	13.9	15.6	16.5	16.5	16.6	16.2	16.6	16.2	16.2	16.2	15.9	17.5	15.6	15.9	15.2	14.4
40	16.8	19.1	21.2	22.6	22	24.1	21.6	24.1	24.1	22.6	22.9	19.3	21.7	21.5	21.7	15.8
50	34.1	38.5	39.4	38.7	35.9	39.4	39.5	39.5	39.5	38.2	32.7	37.5	37.4	36.4	36.9	37.4
60	44	49.7	55.1	61.3	61.3	61.3	56.9	60.6	61.3	60.9	58.2	55.1	54.1	52.5	50.1	57.6
70	62.3	70	76.5	82.4	80.7	81.4	82	83.2	84.3	85.4	81.9	87.7	78.7	80	79.8	83.6
80	72.2	82	88.4	94.2	106	103	102	102	104	111	111	93.6	89.9	98.1	99.9	97
90	111	126	141	154	146	146	140	146	146	124	119	123	115	129	130	109

Size	Nominal output torque M_{N2} in kNm ($n_1=1000$ 1/min)											
	Nominal ratio i_N											
D4RV...	90	100	112	125	140	160	180	200	225	250	315	
50	43.3	44	44.1	44.1	44.1	44.1	44.2	44.2	44.3	46.2	46	46.2
60	68.5	57.8	57.8	65.3	57.8	65.3	65.6	68.8	68.6	68.6	64.9	64.9
70	91.2	91.3	91.4	91.5	91.4	91.6	91.7	91.7	91.8	95.5	94.3	92.9
80	120	131	131	130	129	104	126	128	126	121	116	117
90	176	169	158	176	175	174	174	176	176	157	176	176

Maximum torque M_{k2max} is $2 \times M_{N2}$

Thermal ratings

Size	Fan pcs	Thermal ratings P _{TH} in kW (n ₁ =1500 1/min)																							
		Nominal ratio i _N / Ambient air temperature																							
		D1PSF20-130																							
		Oil surface temperature in the oil sump 80°C / Mineral oil												Oil surface temperature in the oil sump 90°C / Synthetic oil											
i _N = 1.0...1.8				i _N = 2.0...3.55				i _N = 4.0...7.1				i _N = 1.0...1.8				i _N = 2.0...3.55				i _N = 4.0...7.1					
20 °C	30 °C	40 °C	50 °C	20 °C	30 °C	40 °C	50 °C	20 °C	30 °C	40 °C	50 °C	20 °C	30 °C	40 °C	50 °C	20 °C	30 °C	40 °C	50 °C	20 °C	30 °C	40 °C	50 °C		
20	-	53	36	18	1	61	44	26	9	69	51	34	16	70	53	36	18	78	61	44	26	86	69	51	34
	1	115	86	58	29	123	94	66	37	131	102	73	45	144	115	86	58	152	123	94	66	159	131	102	73
	2	148	114	79	44	156	122	87	52	164	129	94	60	183	148	114	79	191	156	122	87	199	164	129	94
30	-	84	56	29	1	97	69	42	14	109	81	54	26	112	84	56	29	124	97	69	42	136	109	81	54
	1	182	137	91	46	195	150	104	59	207	162	116	71	228	182	137	91	241	195	150	104	252	207	162	116
	2	235	180	125	70	248	193	138	83	260	205	150	95	291	235	180	125	303	248	193	138	315	260	205	150
40	-	128	86	44	2	147	105	63	21	165	123	81	39	170	128	86	44	189	147	105	63	207	165	123	81
	1	278	206	139	70	297	228	159	89	315	246	177	107	347	278	208	139	366	297	228	159	384	315	246	177
	2	358	274	191	107	378	294	210	126	396	312	228	144	442	358	274	191	462	378	294	210	480	396	312	228
50	-	201	135	69	3	232	166	100	34	260	194	128	62	267	201	135	69	298	232	166	100	326	260	194	128
	1	436	327	219	110	467	358	249	141	495	386	278	169	545	436	327	219	575	467	358	249	604	495	386	278
	2	563	431	299	168	594	462	330	198	622	490	358	226	695	563	431	299	725	594	462	330	754	622	490	358
60	-	256	172	88	4	295	211	127	43	331	247	163	79	340	256	172	88	379	295	211	127	415	331	247	163
	1	555	417	278	140	594	456	317	179	630	492	353	215	693	555	417	278	732	594	456	317	768	630	492	353
	2	717	549	381	213	755	588	420	252	792	624	456	288	884	717	549	381	923	755	588	420	959	792	624	456
70	-	329	221	113	5	379	271	163	55	425	317	209	101	437	329	221	113	487	379	271	163	533	425	317	209
	1	714	536	358	180	764	586	408	230	810	632	454	276	892	714	536	358	942	764	586	408	988	810	632	454
	2	921	706	490	274	971	756	540	324	1018	802	586	371	1137	921	706	490	1187	971	756	540	1233	1018	802	586
80	-	402	270	138	6	463	331	199	67	520	388	256	124	534	402	270	138	595	463	331	199	652	520	388	256
	1	768	569	371	172	829	630	432	233	885	687	488	290	966	768	569	371	1027	829	630	432	1084	885	687	488
	2	999	759	518	277	1060	820	579	339	1117	876	636	395	1240	999	759	518	1301	1060	820	579	1357	1117	876	636
90	-	457	307	157	7	526	376	226	76	591	441	291	141	607	457	307	157	676	526	376	226	741	591	441	291
	1	872	647	421	196	942	716	491	265	1006	781	555	330	1098	872	647	421	1167	942	716	491	1232	1006	781	555
	2	1135	862	589	315	1205	932	658	385	1269	996	722	449	1409	1135	862	589	1478	1205	932	658	1543	1269	996	722
100	-	557	374	191	8	642	459	276	93	721	538	355	172	740	557	374	191	825	642	459	276	904	721	538	355
	1	1064	789	514	239	1149	874	599	324	1227	952	677	402	1339	1064	789	514	1424	1149	874	599	1503	1227	952	677
	2	1385	1052	718	385	1470	1136	803	469	1548	1215	881	548	1719	1385	1052	718	1803	1470	1136	803	1882	1548	1215	881
110	-	603	405	207	9	695	497	299	101	780	582	384	186	801	603	405	207	893	695	497	299	978	780	582	384
120	-	685	460	235	10	790	565	340	115	886	661	436	211	910	685	460	235	1015	790	565	340	1111	886	661	436
130	-	804	540	276	12	927	663	399	135	1040	776	512	248	1068	804	540	276	1191	927	663	399	1304	1040	766	512

*) Cooling fan for gear unit sizes 80,90,100 only allowed if n₁ < 1200 1/min

Thermal ratings

Size	Fan pcs	Thermal ratings P _{TH} in kW (n ₁ =1500 1/min) Nominal ratio i _N / Ambient air temperature																							
		D2PS.								D3PS.								D4PS.				D5PS			
		Oil surface temperature in the oil sump 90°C / Synthetic Oil																							
		i _N = 6.3...12.5				i _N = 14...18				i _N = 20...56				i _N = 63...90				i _N = 100...400				i _N = 450...1800			
20 °C	30 °C	40 °C	50 °C	20 °C	30 °C	40 °C	50 °C	20 °C	30 °C	40 °C	50 °C	20 °C	30 °C	40 °C	50 °C	20 °C	30 °C	40 °C	50 °C	20 °C	30 °C	40 °C	50 °C		
95	-	453	357	261	166	482	386	290	194	-	-	-	-	-	-	-	-	-	-	-	-	-	-	-	
	1	765	621	477	333	794	650	506	362	-	-	-	-	-	-	-	-	-	-	-	-	-	-	-	
	2	1014	832	650	467	1043	861	679	496	-	-	-	-	-	-	-	-	-	-	-	-	-	-	-	
100	-	504	397	297	184	536	429	323	216	399	320	241	162	424	345	266	187	282	222	163	104	192	145	98	50
	1	-	-	-	-	-	-	-	-	501	406	312	217	526	431	336	242	-	-	-	-	-	-	-	-
	2	-	-	-	-	-	-	-	-	603	493	383	272	628	518	407	297	-	-	-	-	-	-	-	-
110	-	539	425	311	197	573	459	345	231	485	389	293	197	515	419	323	227	342	270	198	126	234	176	119	61
	1	-	-	-	-	-	-	-	-	609	494	379	264	639	524	409	294	-	-	-	-	-	-	-	-
	2	-	-	-	-	-	-	-	-	733	599	465	331	764	629	495	361	-	-	-	-	-	-	-	-
120	-	605	477	349	221	644	516	388	260	530	425	320	215	563	458	353	248	374	295	217	138	256	193	130	67
	1	-	-	-	-	-	-	-	-	870	713	556	398	903	746	589	431	-	-	-	-	-	-	-	-
	2	-	-	-	-	-	-	-	-	1143	944	744	545	1176	977	777	578	-	-	-	-	-	-	-	-
130	-	712	561	411	260	757	607	456	306	606	486	366	246	644	524	404	284	428	338	248	158	292	220	148	76
	1	-	-	-	-	-	-	-	-	995	815	635	455	1032	853	673	493	-	-	-	-	-	-	-	-
	2	-	-	-	-	-	-	-	-	1306	1078	851	623	1344	1116	889	661	-	-	-	-	-	-	-	-
140	-	926	730	534	338	985	789	593	397	667	535	403	271	708	576	444	312	470	371	272	173	321	242	163	84
	1	-	-	-	-	-	-	-	-	-	-	-	-	-	-	-	-	-	-	-	-	-	-	-	-
	2	-	-	-	-	-	-	-	-	-	-	-	-	-	-	-	-	-	-	-	-	-	-	-	-
150	-	1028	811	593	376	1093	876	659	441	758	608	458	308	805	655	505	355	535	422	310	197	365	275	185	95
	1	-	-	-	-	-	-	-	-	-	-	-	-	-	-	-	-	-	-	-	-	-	-	-	-
	2	-	-	-	-	-	-	-	-	-	-	-	-	-	-	-	-	-	-	-	-	-	-	-	-
160	-	1162	916	671	425	1236	990	744	499	869	697	525	353	923	751	579	407	613	484	355	226	419	316	212	109
	1	-	-	-	-	-	-	-	-	-	-	-	-	-	-	-	-	-	-	-	-	-	-	-	-
	2	-	-	-	-	-	-	-	-	-	-	-	-	-	-	-	-	-	-	-	-	-	-	-	-

Size	Fan pcs	Thermal ratings P _{TH} in kW (n ₁ =1500 1/min) Nominal ratio i _N / Ambient air temperature																						
		D2PH.								D3PH.								D4PH.						
		Oil surface temperature in the oil sump 90°C / Synthetic Oil																						
		i _N = 6.3...12.5				i _N = 14...18				i _N = 20...56				i _N = 63...90				i _N = 100...400						
20 °C	30 °C	40 °C	50 °C	20 °C	30 °C	40 °C	50 °C	20 °C	30 °C	40 °C	50 °C	20 °C	30 °C	40 °C	50 °C	20 °C	30 °C	40 °C	50 °C					
95	-	453	357	261	166	482	386	290	194	-	-	-	-	-	-	-	-	-	-	-				
	1	765	621	477	333	794	650	506	362	-	-	-	-	-	-	-	-	-	-	-				
	2	1014	832	650	467	1043	861	679	496	-	-	-	-	-	-	-	-	-	-	-				
100	-	560	442	323	205	596	478	359	241	349	280	211	142	370	301	232	163	246	194	142	91			
	1	-	-	-	-	-	-	-	-	438	355	272	189	459	377	294	211	-	-	-	-			
	2	-	-	-	-	-	-	-	-	527	431	334	238	549	452	356	259	-	-	-	-			
110	-	582	459	336	213	619	496	373	250	414	332	250	168	440	358	276	194	292	231	169	108			
	1	-	-	-	-	-	-	-	-	520	422	323	225	546	447	349	251	-	-	-	-			
	2	-	-	-	-	-	-	-	-	626	512	397	282	652	538	423	308	-	-	-	-			
120	-	-	-	-	-	-	-	-	-	495	397	299	201	526	428	330	232	349	276	202	129			
	1	-	-	-	-	-	-	-	-	812	665	519	372	843	696	549	403	-	-	-	-			
	2	-	-	-	-	-	-	-	-	1067	881	695	509	1097	912	726	540	-	-	-	-			
130	-	-	-	-	-	-	-	-	-	536	430	324	218	569	463	357	251	378	298	219	139			
	1	-	-	-	-	-	-	-	-	879	720	561	402	912	753	594	436	-	-	-	-			
	2	-	-	-	-	-	-	-	-	1154	953	752	550	1187	986	785	584	-	-	-	-			
140	-	-	-	-	-	-	-	-	-	722	579	436	293	767	624	481	338	510	402	295	188			
	1	-	-	-	-	-	-	-	-	-	-	-	-	-	-	-	-	-	-	-	-	-	-	
	2	-	-	-	-	-	-	-	-	-	-	-	-	-	-	-	-	-	-	-	-	-	-	-
150	-	-	-	-	-	-	-	-	-	823	660	497	334	875	712	549	386	581	459	336	214			
	1	-	-	-	-	-	-	-	-	-	-	-	-	-	-	-	-	-	-	-	-	-	-	-
	2	-	-	-	-	-	-	-	-	-	-	-	-	-	-	-	-	-	-	-	-	-	-	-
160	-	-	-	-	-	-	-	-	-	945	758	571	384	1004	817	630	443	666	526	386	246			
	1	-	-	-	-	-	-	-	-	-	-	-	-	-	-	-	-	-	-	-	-	-	-	-
	2	-	-	-	-	-	-	-	-	-	-	-	-	-	-	-	-	-	-	-	-	-	-	-

Thermal ratings

Thermal ratings P_{TH} in kW ($n_1=1500$ 1/min)									
Nominal ratio i_N / Ambient air temperature									
Size	Fan pcs	2KC90M-400M							
		$i_N = 4.0...8.0$				$i_N = 9.0...20.0$			
		20 °C	30 °C	40 °C	50 °C	20 °C	30 °C	40 °C	50 °C
90M	-	15	10	4	-	18	13	8	3
	1	26	19	12	4	29	22	15	8
110M	-	22	14	7	-	27	19	12	4
	1	38	28	17	7	43	33	22	12
140M	-	32	21	10	-	40	29	17	6
	1	57	41	26	10	65	49	33	17
180M	-	48	32	15	-	60	43	26	9
	1	85	62	38	15	97	73	50	26
225M	-	72	47	22	-	89	64	39	14
	1	127	92	57	22	144	109	74	39
250M	-	95	62	29	-	117	84	51	18
	1	167	121	75	29	190	144	97	51
280M	-	121	79	37	-	149	107	65	23
	1	213	154	96	37	241	183	124	65
315M	-	147	96	45	-	181	130	79	28
	1	259	187	116	45	293	222	150	79
355M	-	181	118	55	-	224	161	98	35
	1	320	232	143	55	362	274	186	98
400M	-	233	152	71	-	287	206	125	44
	1	411	298	184	71	466	352	239	125
2TKC90M-400M									
Size	Fan pcs	$i_N = 4.0...8.0$				$i_N = 9.0...20.0$			
		20 °C	30 °C	40 °C	50 °C	20 °C	30 °C	40 °C	50 °C
		20 °C	30 °C	40 °C	50 °C	20 °C	30 °C	40 °C	50 °C
90M	-	15	10	4	-	18	13	8	3
	1	26	19	12	-	29	22	15	8
110M	-	22	14	7	-	27	19	12	4
	1	38	28	17	-	43	33	22	12
140M	-	32	21	10	-	40	29	17	6
	1	57	41	26	-	65	49	33	17
180M	-	48	32	15	-	60	43	26	9
	1	85	62	38	-	97	73	50	26
225M	-	72	47	22	-	89	64	39	14
	1	127	92	57	-	144	109	74	39
250M	-	104	68	32	-	128	92	56	20
	1	183	132	82	-	207	157	106	56
280M	-	134	87	41	-	165	119	72	26
	1	236	171	106	-	267	202	137	72
315M	-	164	107	50	-	202	145	88	31
	1	289	209	130	-	328	248	168	88
355M	-	207	135	63	-	256	184	112	40
	1	365	265	164	-	414	313	212	112
400M	-	259	169	79	-	319	229	139	49
	1	457	331	205	-	517	391	265	139

Thermal ratings P_{TH} in kW ($n_1=1500$ 1/min)													
Nominal ratio i_N / Ambient air temperature													
Size	Fan pcs	3KC140-250								5KC140-250			
		$i_N = 20...40$				$i_N = 45...90$				$i_N = 100...400$			
		20 °C	30 °C	40 °C	50 °C	20 °C	30 °C	40 °C	50 °C	20 °C	30 °C	40 °C	50 °C
140	-	24	17	10	4	27	20	13	7	-	-	-	-
	1	38	29	20	10	42	32	23	13	-	-	-	-
160	-	29	21	13	4	33	25	17	8	18	13	8	3
	1	48	36	24	13	51	40	28	17	27	20	13	6
180	-	35	25	15	5	40	30	20	10	21	15	9	3
	1	57	43	29	15	62	48	34	20	32	24	15	7
200	-	46	33	20	7	52	39	26	13	28	20	12	4
	1	75	56	38	20	81	62	44	26	42	31	20	9
225	-	57	41	25	9	64	48	32	16	34	25	15	5
	1	92	69	47	25	99	77	54	32	51	38	25	11
250	-	67	48	29	10	76	57	38	19	41	29	18	6
	1	109	82	56	29	118	91	65	38	61	45	29	13

Thermal ratings

Thermal ratings P _{TH} in kW (n ₁ =1500 1/min) Nominal ratio i _N / Ambient air temperature													
Size	Fan pcs	3TKC140N-250N/3TKCV140N-250N								5TKC140N-250N			
		i _N = 20...40				i _N = 45...90				i _N = 100...1800			
		20 °C	30 °C	40 °C	50 °C	20 °C	30 °C	40 °C	50 °C	20 °C	30 °C	40 °C	50 °C
140N	-	24	17	10	4	27	20	13	7	-	-	-	-
	1	38	29	20	10	42	32	23	13	-	-	-	-
160N	-	29	21	13	4	33	25	17	8	19	15	10	5
	1	48	36	24	13	51	40	28	17	28	21	15	8
180N	-	35	25	15	5	40	30	20	10	23	17	11	5
	1	57	43	29	15	62	48	34	20	34	26	17	9
200N	-	46	33	20	7	52	39	26	13	31	23	15	7
	1	75	56	38	20	81	62	44	26	45	34	23	12
225N	-	57	41	25	9	64	48	32	16	38	28	18	9
	1	92	69	47	25	99	77	54	32	55	41	28	15
250N	-	67	48	29	10	76	57	38	19	45	33	22	10
	1	109	82	56	29	118	91	65	38	65	49	33	17
3TKCV280N-400N													
280N	-	81	58	35	12	92	69	46	23				
	1	132	100	67	35	143	110	78	46				
315N	-	102	73	44	15	116	87	58	29				
	1	166	126	85	44	180	139	99	58				
355N	-	124	89	54	19	140	105	70	35				
	1	201	152	103	54	217	168	119	70				
400N	-	155	111	67	23	176	132	88	44				
	1	252	191	129	67	273	211	150	88				

Thermal ratings P _{TH} in kW (n ₁ =1500 1/min) Nominal ratio i _N / Ambient air temperature																	
Size	Fan pcs	D3R..								D4R..				D5R..			
		Oil surface temperature in the oil sump 90°C / Synthetic oil															
		i _N = 14...45				i _N = 50...80				i _N = 90...135				i _N = 355...1800			
		20 °C	30 °C	40 °C	50 °C	20 °C	30 °C	40 °C	50 °C	20 °C	30 °C	40 °C	50 °C	20 °C	30 °C	40 °C	50 °C
50	-	131	100	69	38	147	116	85	54	91	70	49	28	65	48	31	14
	1	242	194	146	98	257	210	162	114	-	-	-	-	-	-	-	-
60	-	160	123	85	47	180	142	104	66	113	87	61	35	81	60	39	18
	1	296	237	179	120	316	257	198	139	-	-	-	-	-	-	-	-
70	-	194	148	102	56	218	172	126	80	149	115	80	46	106	78	51	23
	1	358	287	216	145	382	311	240	168	-	-	-	-	-	-	-	-
80	-	228	174	120	66	256	202	148	94	172	132	92	53	122	90	59	27
	1	421	337	254	170	449	365	281	198	-	-	-	-	-	-	-	-
90	-	270	206	142	79	303	239	175	111	208	160	112	64	148	109	71	33
	1	499	400	301	202	532	433	333	234	-	-	-	-	-	-	-	-
95	-	273	208	143	78	309	244	179	114	-	-	-	-	-	-	-	-
	1	505	404	304	203	541	440	340	239	-	-	-	-	-	-	-	-

Thermal ratings P_{TH} in kW ($n_1=1500$ 1/min) Nominal ratio i_N / Ambient air temperature									
Size	Fan pcs	D4RS.				D5RS.			
		$i_N = 90...315$				$i_N = 355...1800$			
		20 °C	30 °C	40 °C	50 °C	20 °C	30 °C	40 °C	50 °C
100	-	257	197	135	79	182	135	88	40
110	-	312	240	168	69	222	164	106	49
120	-	341	262	184	105	424	179	116	53
130	-	390	300	210	120	277	205	133	61
140	-	429	330	231	132	305	226	146	67
150	-	487	375	262	150	346	256	166	76
160	-	559	430	301	172	397	294	191	88

Thermal ratings P_{TH} in kW ($n_1=1500$ 1/min) Nominal ratio i_N / Ambient air temperature									
Size	Fan pcs	D4RH.				D5RH.			
		$i_N = 90...315$				$i_N = 355...1800$			
		20 °C	30 °C	40 °C	50 °C	20 °C	30 °C	40 °C	50 °C
100	-	224	172	121	69	159	118	77	35
110	-	266	205	143	82	189	140	91	42
120	-	318	245	171	98	226	168	109	50
130	-	344	265	185	106	245	181	118	54
140	-	465	357	250	143	330	244	159	73
150	-	529	407	285	163	376	279	181	83
160	-	607	467	327	187	432	320	207	95

Thermal ratings P_{TH} in kW ($n_1=1500$ 1/min) Nominal ratio i_N / Ambient air temperature																					
Size	Fan pcs	D2PV					D3PV					D4PV									
		$i_N = 6.3...12.5$			$i_N = 14...18$		$i_N = 20...56$			$i_N = 63...90$		$i_N = 100...400$									
		20 °C	30 °C	40 °C	50 °C	20 °C	30 °C	40 °C	50 °C	20 °C	30 °C	40 °C	50 °C	20 °C	30 °C	40 °C	50 °C				
10	-	70	54	37	21	76	60	43	27	51	41	30	19	56	45	34	23	-	-	-	-
20	-	77	59	41	23	83	65	47	29	56	44	32	20	61	49	37	25	-	-	-	-
30	-	109	83	58	32	118	92	67	41	80	63	46	29	86	69	52	35	-	-	-	-
40	-	134	103	72	40	145	114	82	51	98	77	56	35	106	85	64	43	-	-	-	-
50	-	192	147	102	57	207	162	117	73	140	110	81	51	152	122	92	62	103	80	58	35
60	-	262	201	140	78	283	222	161	99	192	151	110	69	207	166	125	84	140	109	79	48
70	-	307	235	164	92	332	260	188	116	225	177	129	81	242	194	147	99	164	128	92	56
80	-	352	270	187	105	380	298	215	133	257	203	148	93	278	223	168	113	188	147	106	64
90	-	-	-	-	-	-	-	-	-	309	243	177	111	333	267	202	136	226	176	127	77
100	-	-	-	-	-	-	-	-	-	374	295	215	135	406	326	246	166	333	273	213	154
110	-	-	-	-	-	-	-	-	-	454	357	260	163	492	395	298	202	404	331	259	186
120	-	-	-	-	-	-	-	-	-	496	390	284	179	538	432	326	220	442	362	283	203

Thermal ratings P_{TH} in kW ($n_1=1500$ 1/min) Nominal ratio i_N / Ambient air temperature													
Size	Fan pcs	D3RV..						D4RV..					
		$i_N = 14...45$			$i_N = 50...80$			$i_N = 90...315$					
		20 °C	30 °C	40 °C	50 °C	20 °C	30 °C	40 °C	50 °C	20 °C	30 °C	40 °C	50 °C
30	-	65	47	29	11	77	59	41	23	-	-	-	-
30	1	129	101	73	45	141	113	85	57	-	-	-	-
40	-	79	57	35	13	94	72	50	28	-	-	-	-
40	1	158	124	90	56	172	138	104	70	-	-	-	-
50	-	115	83	51	19	136	104	72	40	96	72	48	24
50	1	229	180	130	81	250	201	151	102	-	-	-	-
60	-	155	112	69	26	183	140	97	54	129	97	65	32
60	1	308	242	175	109	336	270	203	137	-	-	-	-
70	-	183	133	82	31	217	166	115	64	153	115	77	38
70	1	366	287	208	129	399	320	241	162	-	-	-	-
80	-	209	151	93	35	247	189	131	73	174	131	87	44
80	1	416	326	236	146	454	364	274	184	-	-	-	-
90	-	252	182	112	42	298	228	158	88	210	158	105	53
90	1	502	393	285	177	548	439	331	223	-	-	-	-

Exact ratios i_{ex}

Size	Exact ratios i_{ex}															
	Nominal ratio i_N															
D1PSF	1.25	1.4	1.6	1.8	2	2.25	2.5	2.8	3.15	3.55	4	4.5	5	5.6	6.3	7.1
20	1.2593	1.3922	1.5957	1.7727	1.9756	2.2105	2.4857	2.8125	3.2069	3.5185	4.0417	4.5000	5.0435	5.6190	6.3158	7.1765
30	1.2321	1.4038	1.5510	1.7778	1.9762	2.2632	2.5429	2.7879	3.1667	3.5926	4.0000	4.4348	4.9524	5.5789	6.3529	7.1364
40	1.2653	1.4130	1.5814	1.7750	2.0000	2.2647	2.5000	2.8276	3.1481	3.5172	4.0455	4.4167	4.9545	5.5000	6.2222	7.1667
50	1.2558	1.3902	1.6216	1.8000	2.0313	2.2333	2.5000	2.7692	3.2174	3.6190	3.9545	4.4500	5.0000	5.6190	6.3158	7.1765
60	1.2500	1.4146	1.6053	1.8286	2.0303	2.3000	2.5357	2.8077	3.1250	3.5000	3.9500	4.5000	4.9500	5.6111	6.3333	7.0952
70	1.2444	1.3810	1.5897	1.7778	2.0303	2.2258	2.4828	2.8462	3.1667	3.5455	4.0000	4.5556	4.9412	5.5556	6.4211	7.3810
80	1.2558	1.4250	1.5526	1.8529	1.9394	2.2333	2.4643	2.7308	3.0833	3.4545	3.9000	4.4444	4.8947	5.5882	6.2778	7.2857
90	1.2381	1.4103	1.6111	1.8182	2.0000	2.2414	2.4815	2.7600	3.0870	3.4762	3.9474	4.5263	4.9500	5.6667	6.3684	7.0526
100	1.2381	1.4103	1.6111	1.8182	2.0323	2.2414	2.4815	2.7600	3.1600	3.5217	3.9524	4.4211	5.0588	5.5000	6.3125	7.2105
110	1.3000	1.4211	1.5556	1.8750	2.0667	2.2857	2.4074	2.6800	3.1818	3.6000	4.1111	4.4118	4.9412	5.6471	6.0556	7.0556
120	1.2500	1.4146	1.6053	1.7500	2.0000	2.1935	2.4138	2.8077	3.1250	3.5000	3.9500	4.5000	5.1111	5.4211	6.1765	7.0588
130	1.3095	1.3659	1.6216	1.7714	2.0313	2.2333	2.4643	2.7308	3.0417	3.6190	4.1053	4.4444	4.9444	5.5000	6.2778	7.1111

Size	Exact ratios i_{ex}										
	Nominal ratio i_N										
2C../2TC..	6.30	7.10	8.00	9.00	10.00	11.20	12.50	14.00	16.00	18.00	20.00
140N	6.3077	7.1425	8.0372	8.9178	9.812	11.019	12.303	14.03	15.642	17.466	19.61
160N	6.1533	6.9964	7.904	8.8029	9.72	10.972	12.337	14.234	16.005	17.748	19.761
180N	6.3333	7.0722	7.8714	8.9933	10.046	11.103	12.315	14.146	16.342	18.284	20.357
200N	6.2222	6.8627	7.8279	8.8889	9.812	11.301	12.691	14.171	15.818	17.466	19.61
225N	6.2934	7.0829	8.1459	8.9858	9.96	11.05	12.473	14.025	15.66	17.366	19.475
250N	6.4211	7.146	8.141	9.0142	10.167	11.083	12.25	14.152	16.387	18.333	20.074

Size	Exact ratios i_{ex}										
	Nominal ratio i_N										
D2P..	5.6	6.3	7.1	8	9	10	11.2	12.5	14	16	18
50	-	6.2857	6.9954	7.9694	8.8242	9.8214	11.189	12.435	13.918	15.85	17.895
60	-	6.1933	7.0968	7.803	8.7302	10.083	11.189	12.435	13.918	15.85	17.471
70	-	6.1523	6.9424	7.9038	8.8811	9.8737	11.143	12.419	14.259	15.952	17.471
80	-	6.2968	7.1057	8.125	9.1667	10.278	11.435	12.94	14.444	16.322	18.056
90	-	6.2074	7.0113	7.8207	8.9654	10.278	11.435	12.457	14.28	16.086	18.056
95	-	6.2647	7.1	7.9569	8.9323	9.9155	11.3327	12.5729	14.0386	15.7975	18.0225
100	5.4899	6.1486	7	7.7656	8.8103	9.7222	11.229	12.568	13.854	15.833	17.813
110	5.711	6.4615	7.1027	8.0471	9.0581	10.055	11.492	12.75	14.236	16.02	18.023
120	5.7037	6.32	7.0435	7.9239	8.8043	10.044	11.129	12.556	14.087	15.688	17.606
130	5.4545	6.3373	7.1284	7.7931	8.8362	9.8913	11.051	12.63	14.013	15.646	17.607
140	5.5857	6.2727	7.0971	7.9796	9.1071	10.119	11.543	12.791	14.255	15.998	17.81
150	5.5328	6.1581	6.8971	7.7838	8.7919	9.807	11.242	12.508	14.005	15.98	17.517
160	5.6	6.2609	7.0476	7.8947	8.7861	10.009	11.235	12.5	13.995	15.79	17.763

Size	Exact ratios i_{ex}												
	Nominal ratio i_N												
3C../3TC..	22.5	25	28	31.5	35.5	40	45	50	56	63	71	80	90
140N	22.756	25.162	27.355	30.744	35.978	39.585	43.633	48.386	54.026	62.64	70.33	77.24	86.113
160N	22.141	24.751	27.565	30.437	34.482	38.944	43.179	49.348	55.733	64.02	69.046	79.312	88.306
180N	22.919	25.429	27.067	31.383	34.821	38.313	44.421	50.817	56.361	64.741	72.179	80.753	89.911
200N	22.652	25.005	27.744	31.156	34.28	39.483	44.086	51.115	57.058	62.664	69.864	77.141	86.611
225N	22.764	25.232	28.101	31.72	35.025	38.858	43.693	49.347	55.1	63.292	70.47	78.145	87.635
250N	22.407	25.271	28.873	31.913	35.648	39.537	43.102	49.51	57.328	66.23	73.74	82.5	90.335

Continuous allowed external loads

Continuous allowed external loads F_R, F_A

Helical and bevel-helical gear units, D.P. 50-160 and D.R. 50-160

Low speed shaft (LSS) end

1. Determining the allowed radial force F_R

$$F_R = \frac{F_{RN}}{F_S} \cdot K_Y$$

F_R = the allowed actual radial force.

F_{RN} = the allowed nominal radial force in the middle of the shaft end.

F_S = service factor (see gear unit selection, page 1.11)

K_Y = the effect of the radial force location.

2. Gear units with horizontal solid LSS (Types: D.PS, D.RS)

2.1 Radial external forces

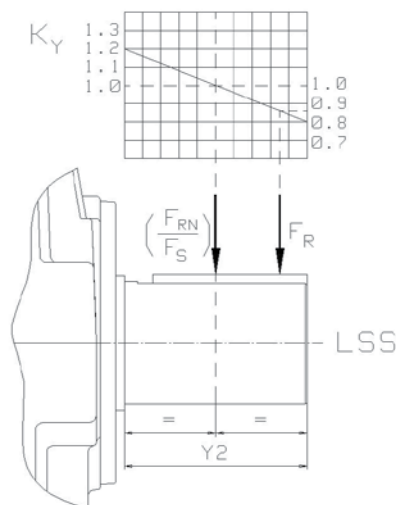

Picture 1: The effect of the radial force location.

Continuous allowed external loads F_R , F_A

Allowed nominal radial forces F when axial force is $F = 0$ kN can be found in the tables 1...3

Table 1: Allowed nominal radial forces F_{RN}

Gear unit type	D2P	D4P	D3P	D3R	D5R
Shaft positions	13,24		14,23	03,04	
Gear unit size	F_{RN} in the middle of the LSS end [kN]				
	LSS speed $LSSn_2$ [1/min]				
	≤10	≤17	≤30	≤60	≤90
50	55	45	38	22	13
60	85	75	50	35	28
70	90	70	33	20	12
80	108	95	61	45	30
90	133	120	72	53	50

Table 2: Allowed nominal radial forces F_{RN}

Gear unit type	D2P	D4P	D3P	D4R	
Shaft positions	13,24		13,24	03,04	
Gear unit size	F_{RN} in the middle of the LSS end [kN]				
	LSS speed $LSSn_2$ [1/min]				
	≤10	≤17	≤30	≤60	≤90
50	100	90	78	58	34
60	141	130	103	84	70
70	150	100	90	54	32
80	192	170	138	116	80
90	241	220	170	144	140

Table 3: Allowed nominal radial forces F_{RN}

Gear unit type	D2P, D3P, D4P, D5P			D4R, D5R	
Shaft positions	13,24,14,23			03,04	
Gear unit size	F_{RN} in the middle of the LSS end [kN]				
	LSS speed $LSSn_2$ [1/min]				
	≤10	≤17	≤30	≤60	≤90
100	244	244	244	241	212
110	275	275	275	275	262
120	309	309	303	290	279
130	338	338	328	291	316
140	367	367	367	367	367
150	391	391	372	351	349
160	264	419	410	385	415

F_{RN} is the allowed radial force to the most unfavourable direction on the LSS end

2.2 Allowed radial force directions for foot mounted gear unit with horizontal solid LSS

Ensure that the gear unit is rigidly mounted in order not to be moved by the external forces.

When the radial force is pointing upwards in the area of segment A as shown in Picture 2, please refer to Santasalo.

High speed shaft (HSS) end

Gear units are dimensioned to take radial forces in the middle of the HSS end. No axial forces F_A are permitted.

V-belt pulley pitch diameter must be greater than 6 times the shaft end diameter.

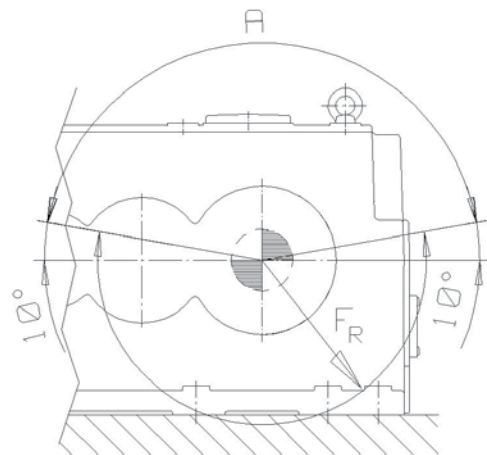

Picture 2: Allowed radial load directions

Continuous allowed external loads

Continuous allowed external loads F_R, F_A

Helical and bevel-helical gear units, D.PV.. 10-90 and D.RV.. 10-90

Low Speed Shaft (LSS) end

1. Determining the allowed radial force F_R and axial force F_A

$$F_R = \frac{F_{RN}}{F_S} \cdot K_Y, \quad F_A = \frac{F_{AN}}{F_S}$$

F_R = the allowed actual radial force.

F_A = the allowed actual axial force.

F_{RN} = the allowed nominal radial force in the middle of the shaft end.

F_{AN} = the allowed nominal axial force on the shaft end

F_S = service factor (see gear unit selection, page 1.10)

K_Y = the effect of the radial force location.

2. Gear units with vertical solid LSS (Types: D.PVS, D.RVS)

2.1 Radial external forces (Picture 1)

Table 1:

Allowed nominal radial forces F when axial force is $F = 0$ kN can be found in the table 1

Table 1: Allowed nominal radial forces F_{RN}

Gear unit size	F_{RN} in the middle of the LSS end [kN]				
	LSS speed $LSSn_2$ [1/min]				
	≤10	≤17	≤30	≤60	≤90
10	50	48	45	31	23
20	59	57	55	51	47
30	89	87	85	82	75
40	112	111	110	100	89
50	153	151	149	134	124
60	189	187	185	182	171
70	258	256	236	209	201
80	311	300	276	255	236
90	397	370	343	315	292
100	Ask	Ask	Ask	Ask	Ask
110	Ask	Ask	Ask	Ask	Ask
120	Ask	Ask	Ask	Ask	Ask

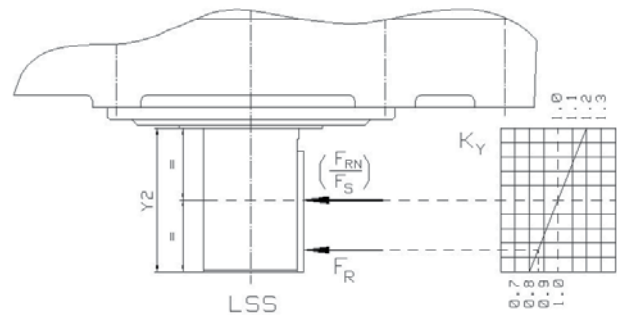

Picture 1: The effect of the radial force location

F_{RN} is the allowed radial force to the most unfavourable direction on the LSS.

Continuous allowed external loads F_R , F_A

2.2 External axial and radial forces (Picture 2)

Table 2: Allowed nominal axial and radial forces F_{AN} and F_{RN} calculated with LSS speed of 50 1/min.

Gear unit size	F_{AN} [kN]	F_{RNL} [kN]	L [m]
10	3	1.3	1.4
20	14	4.9	1.6
30	19	8.4	1.6
40	31	9.6	1.7
50	38	15	1.8
60	50	18	2
70	52	23	2
80	68	34	2
90	70	42	2

Table 2

$$F_R = \frac{F_{RNL}}{F_S}$$

$$F_A = \frac{F_{AN}}{F_S}$$

F_{RNL} = the allowed nominal radial force at the distance L from the shaft end.

Picture 2: Radial and axial forces

Ensure that the gear unit is rigidly mounted in order not to be moved by the external forces.

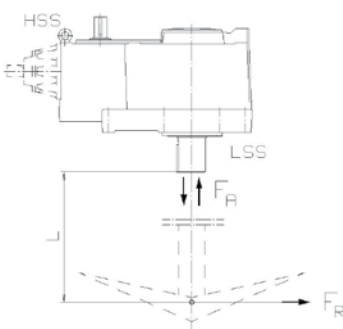

High speed shaft (HSS) end

Gear units are dimensioned to take radial forces in the middle of the HSS end. No axial forces F_A are permitted.

V-belt pulley pitch diameter must be greater than 6 times the shaft end diameter.

Allowed rotational speed

Size	Allowed rotational speed n_{max} in r/min (with splash lubrication)															
	Nominal ratio i_N															
D1PSF	1.25	1.4	1.6	1.8	2	2.25	2.5	2.8	3.15	3.55	4	4.5	5	5.6	6.3	7.1
20	2588	2741	2974	3000	3000	3000	3000	3000	3000	3000	3000	3000	3000	3000	3000	3000
30	1998	2152	2283	2486	2664	2921	3000	3000	3000	3000	3000	3000	3000	3000	3000	3000
40	1622	1728	1848	1987	2148	2338	2506	2741	2800	2800	2800	2800	3000	3000	3000	3000
50	1292	1369	1502	1604	1736	1852	2005	2159	2200	2200	2200	2400	2400	2400	2400	2400
60	1056	1134	1223	1328	1423	1549	1660	1788	1800	1800	1800	1900	1900	1900	1900	1900
70	893	947	1030	1105	1205	1283	1382	1530	1657	1700	1700	1800	1800	1800	1800	1800
80	807	868	914	1021	1052	1157	1240	1335	1462	1500	1500	1700	1700	1700	1700	1700
90	745	802	869	938	999	1079	1159	1252	1300	1300	1300	1400	1400	1400	1400	1400
100	667	719	779	840	904	967	1038	1122	1200	1200	1200	1300	1300	1300	1300	1300
110	633	666	703	791	844	905	938	1013	1100	1100	1100	1100	1100	1100	1100	1100
120	575	617	666	703	767	816	873	950	950	950	950	1100	1100	1100	1100	1100
130	551	564	625	661	723	771	827	850	850	850	850	950	950	950	950	950
D2P...	5.6	6.3	7.1	8	9	10	11.2	12.5	14	16	18					
50	-	2096	2253	2470	2660	2882	3000	3000	3000	3000	3000					
60	-	1810	1985	2122	2302	2565	2779	2800	2800	2800	2800					
70	-	1580	1580	1725	1873	2023	2215	2400	2400	2400	2400					
80	-	1491	1491	1633	1778	1933	2094	2200	2200	2200	2200					
90	-	1368	1485	1604	1771	1771	1900	1900	1900	1900	1900					
95	-	1164	1263	1365	1481	1598	1766	1800	1800	1800	1800					
100	1070	1070	1164	1249	1365	1466	1500	1500	1500	1500	1500					
110	1013	1013	1078	1173	1275	1375	1400	1400	1400	1400	1400					
120	994	994	994	1077	1160	1277	1300	1300	1300	1300	1300					
130	941	941	941	941	1024	1109	1202	1300	1300	1300	1300					
140	879	879	879	879	961	1035	1139	1200	1200	1200	1200					
150	823	823	823	823	893	964	1065	1100	1100	1100	1100					
160	757	757	757	757	814	893	950	950	950	950	950					
D3P..	20	22.5	25	28	31.5	35.5	40	45	50	56	63	71	80	90		
50	2790	3000	3000	3000	3000	3000	3000	3000	3000	3000	3000	3000	3000	3000		
60	2747	2778	2778	2778	2778	2778	2778	2778	2778	2778	2778	2778	2778	2778		
70	2253	2253	2350	2350	2350	2350	2350	2350	2350	2350	2350	2350	2350	2350		
80	2096	2182	2182	2182	2182	2182	2182	2182	2182	2182	2182	2182	2182	2182		
90	1810	1910	1910	1910	1910	1910	1910	1910	1910	1910	1910	1910	1910	1910		
100	1608	1608	1608	1608	1608	1608	1608	1608	1608	1608	1608	1608	1608	1608		
110	1528	1528	1528	1528	1528	1528	1528	1528	1528	1528	1528	1528	1528	1528		
120	1389	1389	1389	1389	1389	1389	1389	1389	1389	1389	1389	1389	1389	1389		
130	1273	1273	1273	1273	1273	1273	1273	1273	1273	1273	1273	1273	1273	1273		
140	1175	1175	1175	1175	1175	1175	1175	1175	1175	1175	1175	1175	1175	1175		
150	1091	1091	1091	1091	1091	1091	1091	1091	1091	1091	1091	1091	1091	1091		
160	1018	1018	1018	1018	1018	1018	1018	1018	1018	1018	1018	1018	1018	1018		
D4P..	100	112	125	140	160	180	200	225	250	280	315	355	400			
50	3000	3000	3000	3000	3000	3000	3000	3000	3000	3000	3000	3000	3000	3000		
60	3000	3000	3000	3000	3000	3000	3000	3000	3000	3000	3000	3000	3000	3000		
70	3000	3000	3000	3000	3000	3000	3000	3000	3000	3000	3000	3000	3000	3000		
80	3000	3000	3000	3000	3000	3000	3000	3000	3000	3000	3000	3000	3000	3000		
90	2546	2546	2546	2546	2546	2546	2546	2546	2546	2546	2546	2546	2546	2546		
100	2182	2182	2182	2182	2182	2182	2182	2182	2182	2182	2182	2182	2182	2182		
110	1910	1910	1910	1910	1910	1910	1910	1910	1910	1910	1910	1910	1910	1910		
120	1797	1797	1797	1797	1797	1797	1797	1797	1797	1797	1797	1797	1797	1797		
130	1697	1697	1697	1697	1697	1697	1697	1697	1697	1697	1697	1697	1697	1697		
140	1608	1608	1608	1608	1608	1608	1608	1608	1608	1608	1608	1608	1608	1608		
150	1528	1528	1528	1528	1528	1528	1528	1528	1528	1528	1528	1528	1528	1528		
160	1389	1389	1389	1389	1389	1389	1389	1389	1389	1389	1389	1389	1389	1389		
	450	500	560	630	710	800	900	1000	1120	1250	1400	1600	1800			
100	2778	2778	2778	2778	2778	2778	2778	2778	2778	2778	2778	2778	2778	2778		
110	2546	2546	2546	2546	2546	2546	2546	2546	2546	2546	2546	2546	2546	2546		
120	2350	2350	2350	2350	2350	2350	2350	2350	2350	2350	2350	2350	2350	2350		
130	2182	2182	2182	2182	2182	2182	2182	2182	2182	2182	2182	2182	2182	2182		
140	2037	2037	2037	2037	2037	2037	2037	2037	2037	2037	2037	2037	2037	2037		
150	1910	1910	1910	1910	1910	1910	1910	1910	1910	1910	1910	1910	1910	1910		
160	1797	1797	1797	1797	1797	1797	1797	1797	1797	1797	1797	1797	1797	1797		

Allowed rotational speed

Size	Allowed rotational speed n_{max} in r/min (with splash lubrication)															
	Nominal ratio i_N															
D3R..	14	16	18	20	22.5	25	28	31.5	35.5	40	45	50	56	63	71	80
50	2059	2059	2059	22059	2297	2297	2297	2297	2297	2474	2474	2474	2474	3000	3000	3000
60	1845	1845	1845	1845	1845	2010	2010	2010	2010	2010	2144	2144	2144	2680	2680	2680
70	1517	1517	1517	1517	1694	1787	1787	1787	1787	2010	2010	2010	2010	2474	2474	2474
80	1517	1517	1517	1517	1517	1694	1787	1787	1787	1787	2010	2010	2010	2010	2474	2474
90	1340	1340	1340	1340	1340	1340	1340	1340	1340	1340	1340	1462	1462	1462	2010	2010
95	983	983	983	983	983	983	1224	1224	1224	1224	1462	1462	1462	1462	1462	1462
D4R..	90	100	112	125	140	160	180	200	225	250	280	315				
50	2924	2924	2924	2924	2924	3000	3000	3000	3000	3000	3000	3000	3000	3000	3000	3000
60	2924	2924	2924	2924	2924	3000	3000	3000	3000	3000	3000	3000	3000	3000	3000	3000
70	2297	2297	2297	2297	2297	2474	2474	2474	2474	2474	2474	2474	2474	3000	3000	3000
80	2297	2297	2297	2297	2297	2297	2474	2474	2474	2474	2474	2474	2474	3000	3000	3000
90	2010	2010	2144	2144	2144	2144	2144	2144	2144	2144	2144	2144	2144	2680	2680	2680
100	1892	1892	1892	1892	1892	1892	1892	1892	2144	2144	2144	2144	2144	2474	2474	2474
110	1831	1831	1892	1892	1892	1892	1892	1892	2144	2144	2144	2144	2144	2680	2680	2680
120	1462	1462	1608	1608	1608	1608	1608	1608	1608	1608	2010	2010	2010	2010	2010	2010
130	1340	1340	1462	1462	1462	1462	1462	1462	1462	1462	1892	1892	1892	1892	1892	1892
140	1224	1224	1340	1340	1340	1340	1340	1340	1340	1340	1787	1787	1787	1787	1787	1787
150	1148	1224	1224	1224	1224	1224	1224	1224	1224	1224	1608	1608	1608	1608	1608	1608
160	1072	1072	1148	1148	1148	1148	1148	1148	1148	1148	1462	1462	1462	1462	1462	1462
D5R..	355	400	450	500	560	630	710	800	900	1000	1120	1250	1400	1600	1800	
50	3000	3000	3000	3000	3000	3000	3000	3000	3000	3000	3000	3000	3000	3000	3000	3000
60	3000	3000	3000	3000	3000	3000	3000	3000	3000	3000	3000	3000	3000	3000	3000	3000
70	3000	3000	3000	3000	3000	3000	3000	3000	3000	3000	3000	3000	3000	3000	3000	3000
80	3000	3000	3000	3000	3000	3000	3000	3000	3000	3000	3000	3000	3000	3000	3000	3000
90	2924	2924	3000	3000	3000	3000	3000	3000	3000	3000	3000	3000	3000	3000	3000	3000
100	2680	2680	2680	2680	2924	2924	2924	2924	3000	3000	3000	3000	3000	3000	3000	3000
110	2297	2297	2297	2297	2474	2474	2474	2474	3000	3000	3000	3000	3000	3000	3000	3000
120	2010	2010	2010	2010	2297	2297	2297	2297	2680	2680	2680	2680	2680	2680	2680	2680
130	1892	1892	1892	1892	2144	2144	2144	2144	2474	2474	2474	2474	2474	2474	2474	2474
140	1892	1892	1892	2144	2144	2144	2144	2680	2680	2680	2680	2680	2680	2680	2680	2680
150	1787	1787	1787	1787	2010	2010	2010	2474	2474	2474	2474	2474	2474	2474	2474	2474
160	1608	1608	1608	1608	1608	1608	1608	2010	2010	2010	2010	2010	2010	2010	2010	2010
Size	Allowed rotational speed n_{max} in r/min (with splash lubrication)															
	Nominal ratio i_N															
D2PV..	6.3	7.1	8	9	10	11.2	12.5	14	16	18						
10	1469	1581	1729	1860	2049	2213	2448	2448	2652	2652						
20	1469	1581	1729	1860	1860	2049	2213	2213	2448	2652						
30	1116	1200	1315	1416	1534	1534	1702	1844	2029	2213						
40	1017	1098	1180	1285	1421	1421	1539	1679	1850	1850						
50	838	901	988	1064	1152	1274	1385	1517	1517	1676						
60	724	794	849	921	1026	1111	1208	1323	1323	1451						
70	632	632	690	749	809	886	963	1074	1176	1268						
80	596	596	653	711	773	837	921	1005	1109	1206						
D3PV..	20	22.5	25	28	31.5	35.5	40	45	50	56	63	71	80	90		
10	3000	3000	3000	3000	3000	3000	3000	3000	3000	3000	3000	3000	3000	3000	3000	3000
20	2705	2920	3000	3000	3000	3000	3000	3000	3000	3000	3000	3000	3000	3000	3000	3000
30	2305	2305	2305	2481	2732	2732	2732	2951	3000	3000	3000	3000	3000	3000	3000	3000
40	1958	2108	2305	2481	2481	2732	2732	2951	3000	3000	3000	3000	3000	3000	3000	3000
50	1488	1753	1888	1888	1888	2046	2270	2459	2705	2705	2705	2951	2951	2951	2951	2951
60	1465	1573	1714	1714	1714	1895	2053	2239	2467	2467	2467	2691	2691	2691	2691	2691
70	1202	1202	1317	1418	1418	1537	1699	1847	2022	2022	2022	2235	2235	2235	2235	2235
80	1117	1317	1418	1537	1537	1699	1847	2022	2022	2022	2182	2182	2182	2182	2182	2182
90	965	1132	1228	1228	1228	1482	1611	1611	1611	1611	1764	1910	1910	1910	1910	1910
100	1389	1389	1389	1389	1389	1389	1389	1389	1389	1389	1389	1389	1389	1389	1389	1389
110	1273	1273	1273	1273	1273	1273	1273	1273	1273	1273	1273	1273	1273	1273	1273	1273
120	1175	1175	1175	1175	1175	1175	1175	1175	1175	1175	1175	1175	1175	1175	1175	1175
D4PV..	100	112	125	140	160	180	200	225	250	280	315	355	400			
50	2951	3000	3000	3000	3000	3000	3000	3000	3000	3000	3000	3000	3000	3000	3000	3000
60	2732	2732	2732	2951	3000	3000	3000	3000	3000	3000	3000	3000	3000	3000	3000	3000
70	2270	2459	2459	2459	2459	2459	2705	2705	2705	2951	2951	2951	2951	2951	2951	2951
80	2046	2046	2270	2459	2459	2705	2705	2705	2705	2951	2951	2951	2951	2951	2951	2951
90	2053	2239	2239	2239	2467	2239	2467	2467	2546	2546	2546	2546	2546	2546	2546	2546
100	1910	1910	1910	1910	1910	1910	1910	1910	1910	1910	1910	1910	1910	1910	1910	1910
110	1528	1528	1528	1528	1528	1528	1528	1528	1528	1528	1528	1528	1528	1528	1528	1528
120	1389	1389	1389	1389	1389	1389	1389	1389	1389	1389	1389	1389	1389	1389	1389	1389

Allowed rotational speed

Size	Allowed rotational speed n_{lmax} in r/min (with splash lubrication)															
	Nominal ratio i_N															
D3RV..	14	16	18	20	22.5	25	28	31.5	35.5	40	45	50	56	63	71	80
30	1799	1799	1799	1799	2367	2367	2517	2821	2821	3000	3000	3000	3000	3000	3000	3000
40	1799	1799	1799	1799	1799	1799	2367	2367	2517	2821	2821	3000	3000	3000	3000	3000
50	1373	1373	1373	1373	1781	1781	1781	1946	2184	2388	2388	2474	2474	3000	3000	3000
60	1230	1230	1230	1230	1230	1394	1592	1592	1758	1948	2141	2141	2141	2680	2680	2680
70	1011	1011	1011	1011	1129	1291	1433	1580	1580	1731	1957	1957	1957	2197	2451	2451
80	1011	1011	1011	1011	1011	1129	1291	1433	1580	1580	1731	1731	1957	1957	2197	2451
90	943	943	943	943	943	1041	1203	1203	1303	1303	1340	1462	1462	1462	2010	2010
D4RV..	90	100	112	125	140	160	180	200	225	250	280	315				
50	2821	2821	2821	2821	3000	3000	3000	3000	3000	3000	3000	3000	3000	3000	3000	3000
60	2367	2367	2517	2517	3000	3000	3000	3000	3000	3000	3000	3000	3000	3000	3000	3000
70	1946	2184	2184	2184	2474	2474	2474	2474	2474	2474	2474	2474	2474	3000	3000	3000
80	1946	1946	1946	2184	2184	2388	2474	2474	2474	2474	2474	2474	2474	3000	3000	3000
90	1758	1948	2141	2141	2141	2141	2141	2141	2141	2141	2141	2141	2680	2680	2680	2680

Allowed rotational speed

Size	Allowed rotational speed n_{Imax} in r/min (Pressure lubrication)															
	Nominal ratio i_N															
D1PSF	1.25	1.4	1.6	1.8	2	2.25	2.5	2.8	3.15	3.55	4	4.5	5	5.6	6.3	7.1
20	4000	4000	4000	4000	4000	4000	4000	4000	4000	4000	4000	4000	4000	4000	4000	4000
30	4000	4000	4000	4000	4000	4000	4000	4000	4000	4000	4000	4000	4000	4000	4000	4000
40	3897	3920	3920	3920	3920	3920	3920	3920	3920	3920	3920	3920	4000	4000	4000	4000
50	3080	3080	3080	3080	3080	3080	3080	3080	3080	3080	3080	3360	3360	3360	3360	3360
60	2520	2520	2520	2520	2520	2520	2520	2520	2520	2520	2520	2660	2660	2660	2660	2660
70	2380	2380	2380	2380	2380	2380	2380	2380	2380	2380	2380	2520	2520	2520	2520	2520
80	2100	2100	2100	2100	2100	2100	2100	2100	2100	2100	2100	2380	2380	2380	2380	2380
90	1820	1820	1820	1820	1820	1820	1820	1820	1820	1820	1820	1960	1960	1960	1960	1960
100	1680	1680	1680	1680	1680	1680	1680	1680	1680	1680	1680	1820	1820	1820	1820	1820
110	1540	1540	1540	1540	1540	1540	1540	1540	1540	1540	1540	1540	1540	1540	1540	1540
120	1330	1330	1330	1330	1330	1330	1330	1330	1330	1330	1330	1540	1540	1540	1540	1540
130	1190	1190	1190	1190	1190	1190	1190	1190	1190	1190	1190	1330	1330	1330	1330	1330
D2P...	5.6	6.3	7.1	8	9	10	11.2	12.5	14	16	18					
50	-	4000	4000	4000	4000	4000	4000	4000	4000	4000	4000					
60	-	3621	3920	3920	3920	3920	3920	3920	3920	3920	3920					
70	-	3161	3161	3360	3360	3360	3360	3360	3360	3360	3360					
80	-	2983	2983	3080	3080	3080	3080	3080	3080	3080	3080					
90	-	2660	2660	2660	2660	2660	2660	2660	2660	2660	2660					
95	-	2329	2520	2520	2520	2520	2520	2520	2520	2520	2520					
100	2100	2100	2100	2100	2100	2100	2100	2100	2100	2100	2100					
110	1960	1960	1960	1960	1960	1960	1960	1960	1960	1960	1960					
120	1820	1820	1820	1820	1820	1820	1820	1820	1820	1820	1820					
130	1820	1820	1820	1820	1820	1820	1820	1820	1820	1820	1820					
140	1680	1680	1680	1680	1680	1680	1680	1680	1680	1680	1680					
150	1540	1540	1540	1540	1540	1540	1540	1540	1540	1540	1540					
160	1330	1330	1330	1330	1330	1330	1330	1330	1330	1330	1330					
D3P..	20	22.5	25	28	31.5	35.5	40	45	50	56	63	71	80	90		
50	3820	3820	3820	3820	3820	3820	3820	3820	3820	3820	3820	3820	3820	3820		
60	3472	3472	3472	3472	3472	3472	3472	3472	3472	3472	3472	3472	3472	3472		
70	2938	2938	2938	2938	2938	2938	2938	2938	2938	2938	2938	2938	2938	2938		
80	2728	2728	2728	2728	2728	2728	2728	2728	2728	2728	2728	2728	2728	2728		
90	2387	2387	2387	2387	2387	2387	2387	2387	2387	2387	2387	2387	2387	2387		
100	2010	2010	2010	2010	2010	2010	2010	2010	2010	2010	2010	2010	2010	2010		
110	1910	1910	1910	1910	1910	1910	1910	1910	1910	1910	1910	1910	1910	1910		
120	1736	1736	1736	1736	1736	1736	1736	1736	1736	1736	1736	1736	1736	1736		
130	1591	1591	1591	1591	1591	1591	1591	1591	1591	1591	1591	1591	1591	1591		
140	1469	1469	1469	1469	1469	1469	1469	1469	1469	1469	1469	1469	1469	1469		
150	1364	1364	1364	1364	1364	1364	1364	1364	1364	1364	1364	1364	1364	1364		
160	1273	1273	1273	1273	1273	1273	1273	1273	1273	1273	1273	1273	1273	1273		
D4P..	100	112	125	140	160	180	200	225	250	280	315	355	400			
50	4000	4000	4000	4000	4000	4000	4000	4000	4000	4000	4000	4000	4000			
60	4000	4000	4000	4000	4000	4000	4000	4000	4000	4000	4000	4000	4000			
70	3820	3820	3820	3820	3820	3820	3820	3820	3820	3820	3820	3820	3820			
80	3820	3820	3820	3820	3820	3820	3820	3820	3820	3820	3820	3820	3820			
90	3183	3183	3183	3183	3183	3183	3183	3183	3183	3183	3183	3183	3183			
100	2728	2728	2728	2728	2728	2728	2728	2728	2728	2728	2728	2728	2728			
110	2387	2387	2387	2387	2387	2387	2387	2387	2387	2387	2387	2387	2387			
120	2247	2247	2247	2247	2247	2247	2247	2247	2247	2247	2247	2247	2247			
130	2122	2122	2122	2122	2122	2122	2122	2122	2122	2122	2122	2122	2122			
140	2010	2010	2010	2010	2010	2010	2010	2010	2010	2010	2010	2010	2010			
150	1910	1910	1910	1910	1910	1910	1910	1910	1910	1910	1910	1910	1910			
160	1736	1736	1736	1736	1736	1736	1736	1736	1736	1736	1736	1736	1736			
D5P..	450	500	560	630	710	800	900	1000	1120	1250	1400	1600	1800			
100	2778	3472	3472	3472	3472	3472	3472	3472	3472	3472	3472	3472	3472			
110	2546	3183	3183	3183	3183	3183	3183	3183	3183	3183	3183	3183	3183			
120	2350	2938	2938	2938	2938	2938	2938	2938	2938	2938	2938	2938	2938			
130	2182	2728	2728	2728	2728	2728	2728	2728	2728	2728	2728	2728	2728			
140	2037	2546	2546	2546	2546	2546	2546	2546	2546	2546	2546	2546	2546			
150	1910	2387	2387	2387	2387	2387	2387	2387	2387	2387	2387	2387	2387			
160	1797	2247	2247	2247	2247	2247	2247	2247	2247	2247	2247	2247	2247			

Allowed rotational speed

Size	Allowed rotational speed n_{max} in r/min (Pressure lubrication)															
	Nominal ratio i_N															
D3R..	14	16	18	20	22.5	25	28	31.5	35.5	40	45	50	56	63	71	80
50	2872	2872	2872	2872	2872	2872	2872	2872	2872	3093	3093	3093	3093	4000	4000	4000
60	2513	2513	2513	2513	2513	2513	2513	2513	2513	2513	2680	2680	2680	3350	3350	3350
70	2233	2233	2233	2233	2233	2233	2233	2233	2233	2233	2513	2513	2513	3093	3093	3093
80	2233	2233	2233	2233	2233	2233	2233	2233	2233	2233	2233	2233	2233	2513	3093	3093
90	1668	1668	1668	1668	1668	1668	1668	1668	1668	1668	1668	1668	1827	1827	1827	2513
95	1493	1493	1493	1493	1493	1493	1493	1493	1493	1493	1493	1827	1827	1827	1827	1827
D4R..	90	100	112	125	140	160	180	200	225	250	280	315				
50	3655	3655	3655	3655	4000	4000	4000	4000	4000	4000	4000	4000				
60	3655	3655	3655	3655	4000	4000	4000	4000	4000	4000	4000	4000				
70	2872	2872	2872	2872	3093	3093	3093	3093	3093	3093	4000	4000				
80	2872	2872	2872	2872	3093	3093	3093	3093	3093	3093	4000	4000				
90	2513	2513	2680	2680	2680	2680	2680	2680	2680	2680	2680	3350				
100	2365	2365	2365	2365	2365	2365	2365	2680	2680	2680	2680	3093				
110	2365	2365	2365	2365	2365	2365	2365	2680	2680	2680	2680	3350				
120	1827	1827	2010	2010	2010	2010	2010	2010	2010	2513	2513	2513				
130	1668	1668	1827	1827	1827	1827	1827	1827	1827	2365	2365	2365				
140	1493	1493	1668	1668	1668	1668	1668	1668	2233	2233	2233	2233				
150	1405	1493	1493	1493	1493	1493	1493	1493	2010	2010	2010	2010				
160	1317	1317	1405	1405	1405	1405	1405	1405	1405	1827	1827	1827				
D5R..	355	400	450	500	560	630	710	800	900	1000	1120	1250	1400	1600	1800	
50	4000	4000	4000	4000	4000	4000	4000	4000	4000	4000	4000	4000	4000	4000	4000	
60	4000	4000	4000	4000	4000	4000	4000	4000	4000	4000	4000	4000	4000	4000	4000	
70	4000	4000	4000	4000	4000	4000	4000	4000	4000	4000	4000	4000	4000	4000	4000	
80	4000	4000	4000	4000	4000	4000	4000	4000	4000	4000	4000	4000	4000	4000	4000	
90	3655	3655	4000	4000	4000	4000	4000	4000	4000	4000	4000	4000	4000	4000	4000	
100	3350	3350	3350	3350	3655	3655	3655	3655	4000	4000	4000	4000	4000	4000	4000	
110	2872	2872	2872	2872	3093	3093	3093	3093	4000	4000	4000	4000	4000	4000	4000	
120	2513	2513	2513	2513	2872	2872	2872	2872	3350	3350	3350	3350	3350	3350	3350	
130	2365	2365	2365	2365	2680	2680	2680	3093	3093	3093	3093	3093	3093	3093	3093	
140	2365	2365	2365	2680	2680	2680	2680	3350	3350	3350	3350	3350	3350	3350	3350	
150	2233	2233	2233	2233	2513	2513	2513	3093	3093	3093	3093	3093	3093	3093	3093	
160	2010	2010	2010	2010	2010	2010	2010	2513	2513	2513	2513	2513	2513	2513	2513	

Size	Allowed rotational speed n_{max} in r/min (Pressure lubrication)													
	Nominal ratio i_N													
D2PV..	6.3	7.1	8	9	10	11.2	12.5	14	16	18				
10	4000	4000	4000	4000	4000	4000	4000	4000	4000	4000				
20	4000	4000	4000	4000	4000	4000	4000	4000	4000	4000				
30	3820	3820	3820	3820	3820	3820	3820	3820	3820	3820				
40	3472	3472	3472	3472	3472	3472	3472	3472	3472	3472				
50	2728	2728	2728	2728	2728	2728	2728	2728	2728	2728				
60	2387	2387	2387	2387	2387	2387	2387	2387	2387	2387				
70	2010	2010	2010	2010	2010	2010	2010	2010	2010	2010				
80	1910	1910	1910	1910	1910	1910	1910	1910	1910	1910				
D3PV..	20	22.5	25	28	31.5	35.5	40	45	50	56	63	71	80	90
10	4000	4000	4000	4000	4000	4000	4000	4000	4000	4000	4000	4000	4000	4000
20	4000	4000	4000	4000	4000	4000	4000	4000	4000	4000	4000	4000	4000	4000
30	4000	4000	4000	4000	4000	4000	4000	4000	4000	4000	4000	4000	4000	4000
40	4000	4000	4000	4000	4000	4000	4000	4000	4000	4000	4000	4000	4000	4000
50	3820	3820	3820	3820	3820	3820	3820	3820	3820	3820	3820	3820	3820	3820
60	3472	3472	3472	3472	3472	3472	3472	3472	3472	3472	3472	3472	3472	3472
70	2938	2938	2938	2938	2938	2938	2938	2938	2938	2938	2938	2938	2938	2938
80	2728	2728	2728	2728	2728	2728	2728	2728	2728	2728	2728	2728	2728	2728
90	2387	2387	2387	2387	2387	2387	2387	2387	2387	2387	2387	2387	2387	2387
100	1736	1736	1736	1736	1736	1736	1736	1736	1736	1736	1736	1736	1736	1736
110	1591	1591	1591	1591	1591	1591	1591	1591	1591	1591	1591	1591	1591	1591
120	1469	1469	1469	1469	1469	1469	1469	1469	1469	1469	1469	1469	1469	1469
D4PV..	100	112	125	140	160	180	200	225	250	280	315	355	400	
50	4000	4000	4000	4000	4000	4000	4000	4000	4000	4000	4000	4000	4000	
60	4000	4000	4000	4000	4000	4000	4000	4000	4000	4000	4000	4000	4000	
70	3820	3820	3820	3820	3820	3820	3820	3820	3820	3820	3820	3820	3820	
80	3820	3820	3820	3820	3820	3820	3820	3820	3820	3820	3820	3820	3820	
90	3183	3183	3183	3183	3183	3183	3183	3183	3183	3183	3183	3183	3183	
100	2387	2387	2387	2387	2387	2387	2387	2387	2387	2387	2387	2387	2387	
110	1910	1910	1910	1910	1910	1910	1910	1910	1910	1910	1910	1910	1910	
120	1736	1736	1736	1736	1736	1736	1736	1736	1736	1736	1736	1736	1736	

Allowed rotational speed

Size	Allowed rotational speed n_{imax} in r/min (Pressure lubrication)															
	Nominal ratio i_N															
D3RV..	14	16	18	20	22.5	25	28	31.5	35.5	40	45	50	56	63	71	80
30	3655	3655	3655	3655	3655	3655	3655	3655	3655	4000	4000	4000	4000	4000	4000	4000
40	3655	3655	3655	3655	3655	3655	3655	3655	3655	3655	3655	4000	4000	4000	4000	4000
50	2872	2872	2872	2872	2872	2872	2872	2872	2872	3093	3093	3093	3093	4000	4000	4000
60	2513	2513	2513	2513	2513	2513	2513	2513	2513	2513	2680	2680	2680	3350	3350	3350
70	2233	2233	2233	2233	2233	2233	2233	2233	2233	2513	2513	2513	2513	3093	3093	3093
80	2233	2233	2233	2233	2233	2233	2233	2233	2233	2233	2513	2513	2513	2513	3093	3093
90	1668	1668	1668	1668	1668	1668	1668	1668	1668	1668	1668	1827	1827	1827	2513	2513
D4RV..	90	100	112	125	140	160	180	200	225	250	280	315				
50	3655	3655	3655	3655	4000	4000	4000	4000	4000	4000	4000	4000	4000	4000	4000	4000
60	3655	3655	3655	3655	4000	4000	4000	4000	4000	4000	4000	4000	4000	4000	4000	4000
70	2872	2872	2872	2872	3093	3093	3093	3093	3093	3093	3093	3093	3093	4000	4000	4000
80	2872	2872	2872	2872	2872	3093	3093	3093	3093	3093	3093	3093	3093	4000	4000	4000
90	2513	2513	2680	2680	2680	2680	2680	2680	2680	2680	2680	2680	2680	3350	3350	3350

1-stage helical gear units

Gear unit dimensions, type D1PSF20-130

Foot mounting face machined for foot mounting

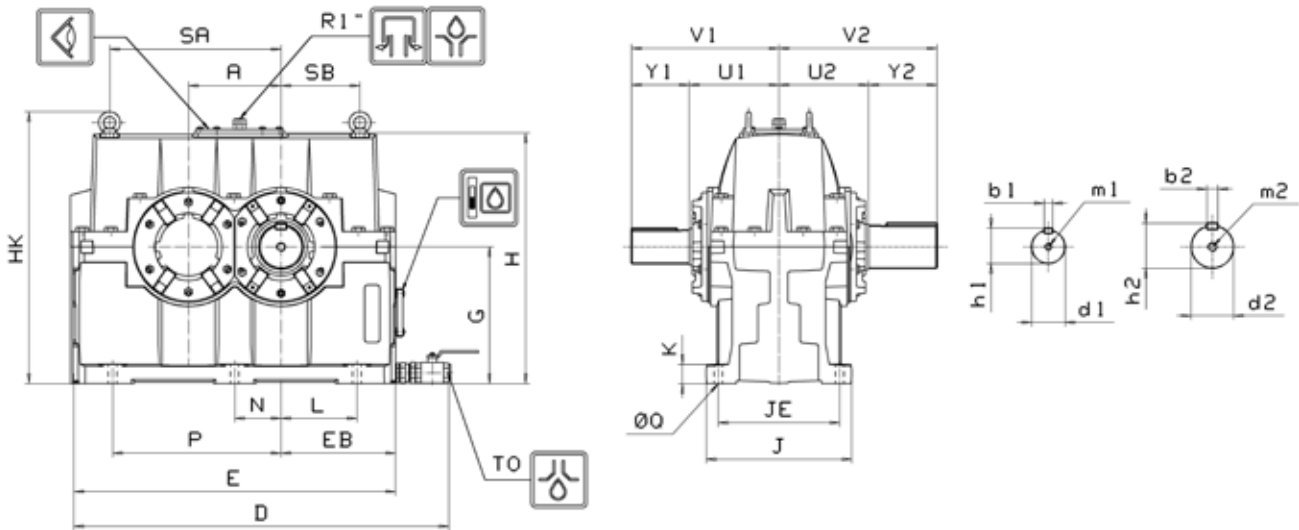

Size	Gear dimensions in mm																	
	A	D	E	EB	G	H	HK	SA	SB	SE	J	JE	K	L	N	P	ØQ	TO
20	125	561	446	158	200	360	405	220	95	74	230	190	23	117	-	243	15	3/4"
30	160	682	567	200	250	460	513	284	124	104	280	235	34	150	-	310	19	3/4"
40	200	847	707	250	300	580	642	362	163	130	350	300	43	195	-	395	24	1"
50	250	1118	943	342	375	720	790	480	230	160	430	360	43	225	-	475	28	1 1/2"
60	305	1247	1072	379	450	825	895	565	260	200	480	400	63	250	-	555	28	1 1/2"
70	360	1380	1205	418	500	930	1020	650	290	200	540	450	63	280	-	640	35	1 1/2"
80	400	1556	1381	485	530	1000	1090	740	340	230	590	480	63	330	200	730	42	1 1/2"
90	430	1657	1482	520	560	1065	1174	792	362	254	630	520	72	355	215	785	42	1 1/2"
100	480	1798	1623	565	630	1205	1314	870	390	270	670	560	73	400	240	880	42	1 1/2"
110	520	1897	1722	601	670	1265	1374	935	415	290	730	620	70	440	260	960	42	1 1/2"
120	560	1997	1822	631	710	1335	1463	990	430	300	770	630	70	450	280	1010	48	1 1/2"
130	600	2082	1922	660	750	1415	-	-	-	-	790	660	65	530	300	1130	48	1 1/2"

Shaft Positions

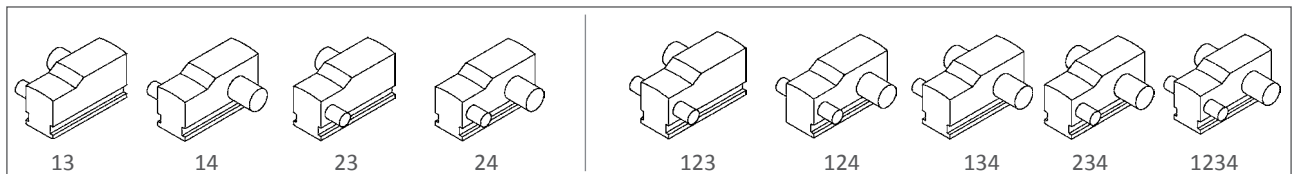

1-stage helical gear units

Size	Shaft dimensions in mm																		
	Input shaft																		U1
	$i_N=1.0...3.55$						$i_N=4.0...4.5$						$i_N=5.0...7,1$						
Y1	V1	d1	b1	h1	m1	Y1	V1	d1	b1	h1	m1	Y1	V1	d1	b1	h1	m1		
20	150	95	245	45k6	14h9	48.5	M16	70	220	35k6	10h9	38	M12	60	210	25k6	8h9	28	M10
30	175	125	300	60m6	18h9	64	M20	95	270	50k6	14h9	53.5	M16	70	245	35k6	10h9	38	M12
40	209	125	334	75m6	20h9	79.5	M20	125	334	65m6	18h9	69	M20	95	304	45k6	14h9	48.5	M16
	$i_N=1.0...4.0$						$i_N=4.5...5.0$						$i_N=5.6...7.1$						
50	259	150	409	90m6	25h9	95	M24	150	409	85m6	22h9	90	M20	125	384	60m6	18h9	64	M20
60	296	190	486	110m6	28h9	116	M24	190	486	100m6	28h9	106	M24	150	446	80m6	22h9	85	M20
70	311	190	501	120m6	32h9	127	M24	190	501	110m6	28h9	116	M24	150	461	90m6	25h9	95	M24
80	340	225	565	130m6	32h9	137	M24	190	530	120m6	32h9	127	M24	190	530	100m6	28h9	106	M24
90	370	225	595	150m6	36h9	158	M30	225	595	140m6	36h9	148	M30	190	560	120m6	32h9	127	M24
100	390	270	660	170m6	40h9	179	M30	270	660	160m6	40h9	169	M30	225	615	135m6	36h9	143	M30
110	421	315	736	190m6	45h9	200	M20(1)	270	691	180m6	45h9	190	M30	225	646	150m6	36h9	158	M30
120	440	315	755	210m6	50h9	221	M20(1)	315	755	190m6	45h9	200	M20(1)	270	710	160m6	40h9	169	M30
130	460	315	775	230m6	50h9	241	M24(1)	315	775	210m6	50h9	221	M20(1)	270	730	170m6	40h9	179	M30

1) 2X180° distance 0,6 x d1

Size	Shaft dimensions in mm							Weight	Splash lubrication Quantity of oil
	Output shaft								
	U2	Y2	V2	d2	b2	h2	m2	kg	l
20	150	95	245	45k6	14h9	48.5	M16	95	7.2
30	175	125	300	60m6	18h9	64	M20	181	13.8
40	211	150	361	90m6	25h9	95	M24	342	26.2
50	261	190	451	110m6	28h9	116	M24	647	54
60	296	225	521	140m6	36h9	148	M30	1038	86
70	313	225	538	150m6	36h9	158	M30	1334	112
80	338	270	608	170m6	40h9	179	M30	1749	143
90	376	315	691	190m6	45h9	200	M20(1)	2233	184
100	396	315	711	210m6	50h9	221	M20(1)	2901	240
110	422	315	737	230m6	50h9	241	M24(1)	3480	248
120	441	370	811	250m6	56h9	262	M24(1)	4234	295
130	461	425	886	290m6	63h9	302	M24(1)	5206	339

1) 2X180° distance 0,6 x d1

Size	Quantity of oil (l), pressure lubrication							
	Nominal ratio i_N							
D1PSF	1.4	1.8	2.25	2.8	3.55	4.5	5.6	7.1
20	6.2	5.6	5.4	5.1	4.7	4.6	4.4	4.0
30	12.1	11.1	10.6	10.0	9.1	9.0	8.5	7.9
40	23.1	21.2	20.2	18.9	17.4	16.8	15.9	14.7
50	47.2	43.1	41.1	38.6	35.3	34.1	32.5	30.2
60	76.6	69.5	65.8	61.8	57.3	55.0	51.9	48.5
70	103	90.6	85.0	78.2	72.0	67.7	64.3	59
80	125	112	106	98.0	89.1	83.0	77.4	70.4
90	162	146	136	125	114	105	97.6	90.1
100	214	193	180	167	151	141	132	120
110	221	199	183	172	153	142	129	121
120	271	248	226	205	187	170	158	145
130	316	283	257	234	208	192	176	168

2-stage helical gear units

Gear unit dimensions, type 2C140N-250N

Torque arm mounting bracket with unmachined foot plane

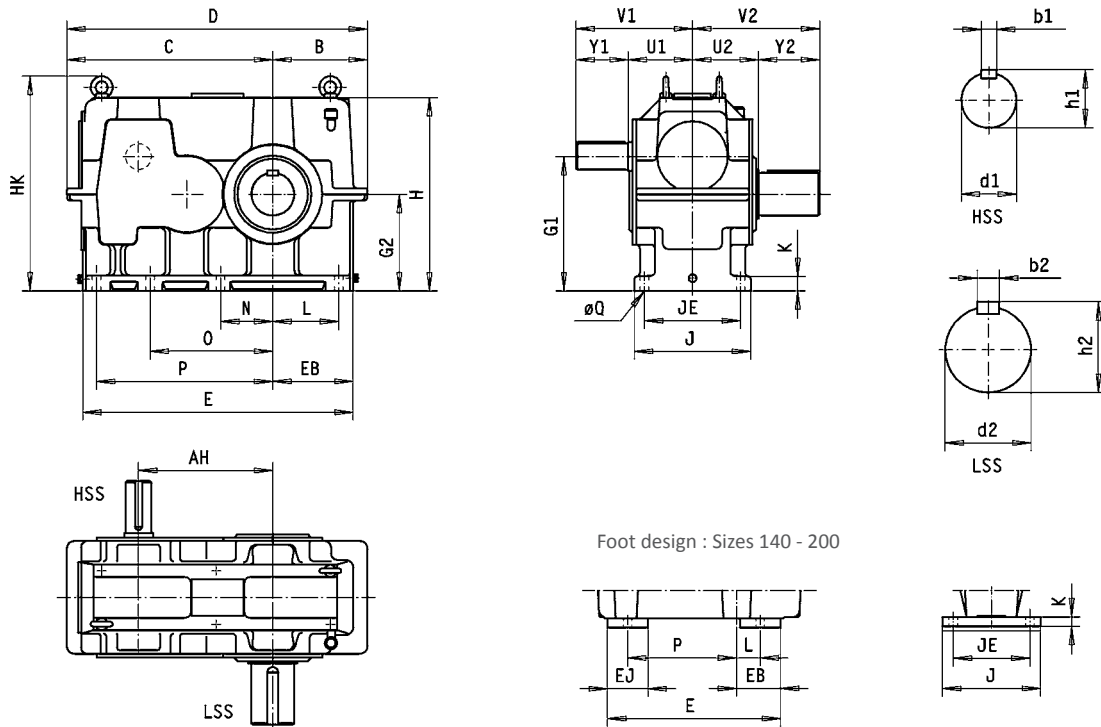

Foot design : Sizes 140 - 200

Size	Gear dimensions in mm																		
	AH	B	C	D	E	EB	EJ	G1	G2	H	HK	J	JE	K	L	N	O	P	Q
140N	211.4	160	355	515	409	104	114	270.1	200	380	433	220	182	20	46	-	-	248	19
160N	238.5	175	404	579	468	113	125	302.1	225	425	478	260	210	25	50	-	-	292	24
180N	270.1	205	450	655	521	131	140	336.7	250	475	537	280	225	25	60	-	-	320	24
200N	310.0	225	500	725	582	152	150	366.6	280	530	592	320	250	30	77	-	-	355	28
225N	352.5	255	555	810	692	200	-	376.7	280	560	631	325	265	40	165	135	-	455	28
250N	391.9	281	606	887	771	225	-	390.7	280	560	631	355	286	45	192	145	-	510	28

Size	Shaft dimensions in mm																	Weight kg	Quantity of oil l
	Input shaft								Output shaft										
	$i_N=5.6...13$				$i_N=13...21$														
	U1	Y1	V1	d1	b1	h1	Y1 1)	V1	d1	b1	h1	U2	Y2	V2	d2	b2	h2		
140N	136	80	216	35k6	10h9	38	80	216	30k6	8h9	33	120	105	225	65m6	18h9	69	100	4.5
160N	150	110	260	40k6	12h9	43	80	230	35k6	10h9	38	140	105	245	75m6	20h9	79.5	140	6.5
180N	157	110	267	50k6	14h9	53.5	110	267	40k6	12h9	43	145	130	275	85m6	22h9	90	190	8.5
200N	167	110	277	55m6	16h9	59	110	277	50k6	14h9	53.5	155	130	285	95m6	25h9	100	260	12
225N	184	140	324	65m6	18h9	69	110	294	55m6	16h9	59	175	165	340	110m6	28h9	116	360	22
250N	200	140	340	75m6	20h9	79.5	140	340	65m6	18h9	69	195	165	360	120m6	32h9	127	490	30

1) Shaft end length for fan on opposite side of motor

Shaft Positions

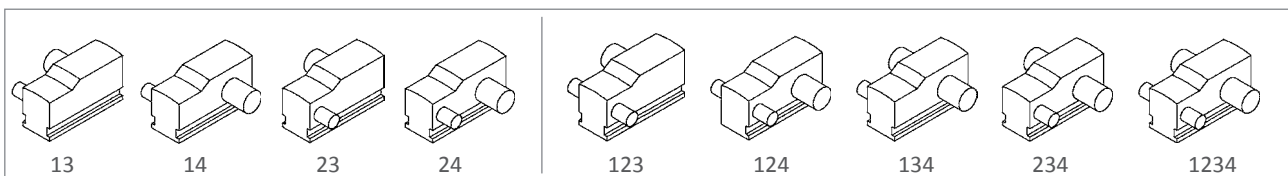

2-stage helical gear units

Gear unit dimensions, type 2TC140N-250N

Torque arm mounting bracket with unmachined foot plane

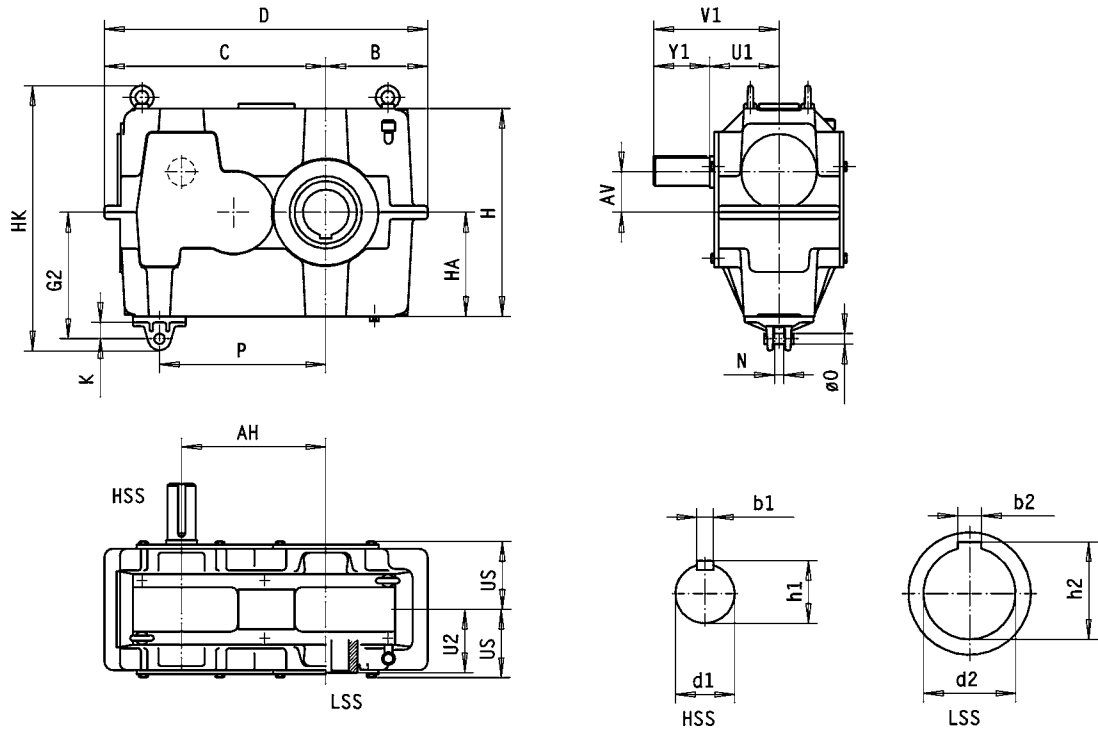

The dimensions of the hollow shaft hole: Page 12.01

Size	Gear dimensions in mm													
	AH	AV	B	C	D	G2	H	HA	HK	K	N	O	P	US
140N	211.4	70.1	160	355	515	223	360	180	481	28	20	22h9	250	114
160N	238.5	77.1	175	404	579	243	400	200	521	28	20	22h9	285	131
180N	270.1	86.7	205	450	655	273	450	225	585	28	20	22h9	320	139
200N	310	86.6	225	500	725	298	500	250	635	28	20	22h9	360	149
225N	352.5	96.7	255	555	810	343	560	280	729	38	32	32h9	405	167
250N	391.9	110.7	281	606	887	346	560	280	729	38	32	32h9	450	187

Size	Shaft dimensions in mm														Weight kg	Quantity of oil l	
	Input shaft								Hollow shaft								
	$i_N=5.6...13$				$i_N=14...21$				U2	d2	b2	h2					
	U1	Y1	V1	d1	b1	h1	Y1	V1	d1	b1	h1	U2	d2	b2	h2		
140N	136	80	216	35k6	10h9	38	80	216	30k6	8h9	33	100	70H8	20JS9	74.9	100	4.5
160N	150	110	260	40k6	12h9	43	80	230	35k6	10h9	38	118	80H8	22JS9	85.4	140	6.6
180N	157	110	267	50k6	14h9	53.5	110	267	40k6	12h9	43	125	90H8	25JS9	95.4	190	8.5
200N	167	110	277	55m6	16h9	59	110	277	50k6	14h9	53.5	135	100H8	28JS9	106.4	260	12
225N	184	140	324	65m6	18h9	69	110	294	55m6	16h9	59	154	110H8	28JS9	116.4	360	15
250N	200	140	340	75m6	20h9	79.5	140	340	65m6	18h9	69	172	120H8	32JS9	127.4	490	17

Shaft Positions

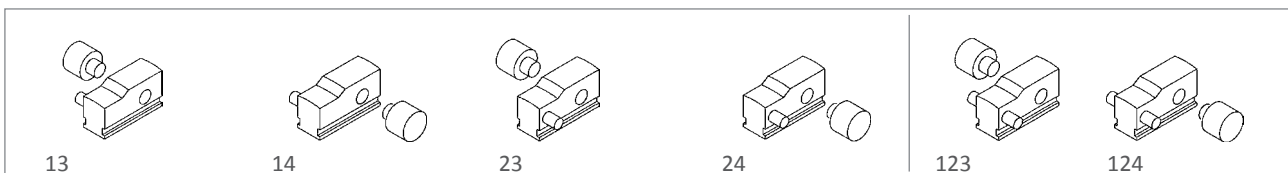

2-stage helical gear units, horizontal LSS

Gear unit dimensions, type D2PSF D2PHF D2PHT

Foot mounting face machined for foot mounting, type D2PSF D2PHF

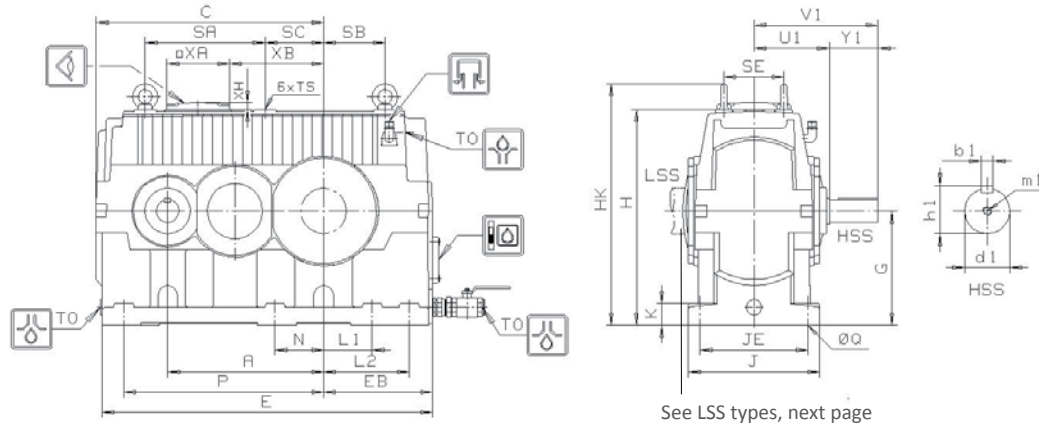

See LSS types, next page

Torque arm mounting bracket with unmachined foot plane, type D2PHT

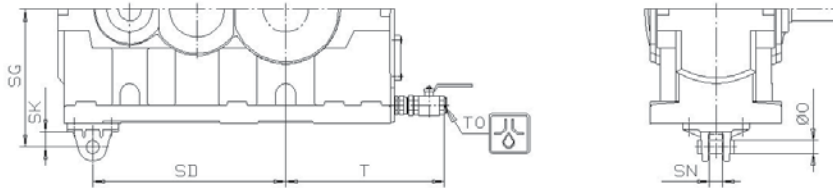

Size	Housing dimensions in mm																			Torque arm mounting bracket Type D2PHT				Foot mounting Type D2PSF D2PHF						
	A	C	E	EB	G	H	HK	J	K	SA	SB	SC	SE	TS	TO	T	XA	XB	XH	O	SD	SG	SK	SN	JE	L1	L2	N	P	Q
50	474	687	994	325	350	660	731	396	65	376	190	175	188	M20x35	R1 1/2	500	220	253	30	32	580	418	38	32	330	148	245	148	600	28
60	546	799	1149	373	400	755	845	460	76	420	215	205	216	M24x42	R1 1/2	548	220	305	30	45	676	482	52	45	378	170	300	170	700	35
70	623	922	1320	427	460	870	960	506	82	460	276	270	250	M24x42	R1 1/2	602	260	370	30	45	795	542	52	45	416	194	322	194	800	35
80	673	972	1418	470	505	955	1045	552	90	490	300	280	250	M24x42	R1 1/2	645	260	390	30	45	845	587	52	45	454	209	369	209	853	42
90	737	1071	1551	512	550	1040	1149	584	97	588	346	291	280	M30x53	R1 1/2	687	260	455	30	45	945	632	52	45	480	228	418	228	945	42

Size	HSS dimensions in mm																			Weight kg	Oil capacity	
	D2PSF						D2PHF, D2PHT						D2PHF, D2PHT						Splash lubrication l		Pressure lubrication l	
	$i_N=6.3...18$						$i_N=6.3...14$						$i_N=14...18$									
	U1	Y1	V1	d1	b1	h1	m1	Y1	V1	d1	b1	h1	m1	Y1	V1	d1	b1	h1	m1			
50	238	125	363	75m6	20h9	79.5	M20	125	363	75m6	20h9	79.5	M20	125	363	60m6	18h9	64	M20	770	44	38
60	255	150	405	80m6	22h9	85	M20	150	405	80m6	22h9	85	M20	125	380	70m6	20h9	74.5	M20	1150	48	41
70	287	150	437	95m6	25h9	100	M24	150	437	95m6	25h9	100	M24	150	437	80m6	22h9	85	M20	1695	74	64
80	307	190	497	100m6	28h9	106	M24	190	497	100m6	28h9	106	M24	150	457	85m6	22h9	90	M20	2150	89	79
90	330	190	520	110m6	28h9	116	M24	190	520	110m6	28h9	116	M24	150	480	95m6	25h9	100	M24	2830	118	105

Shaft Positions

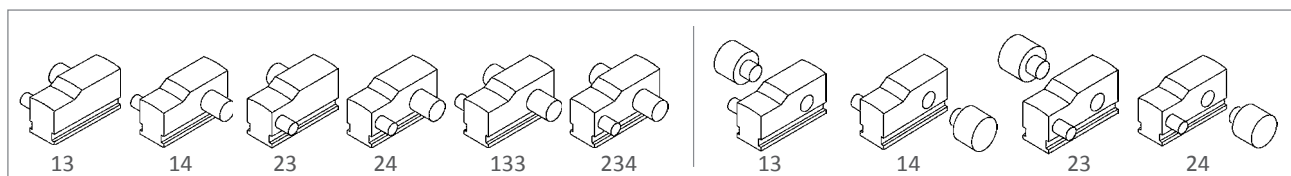

2-stage helical gear units, horizontal LSS

LLS types

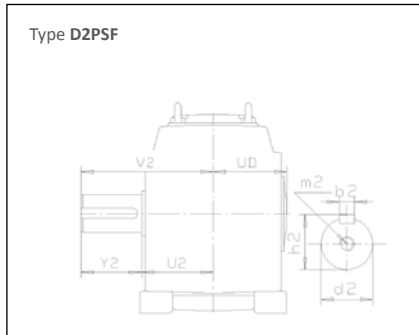

Solid shaft

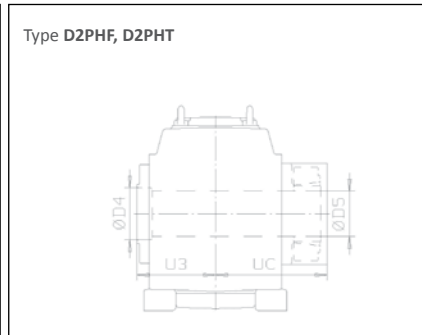

Hollow shaft, shrink disk, page 12.07

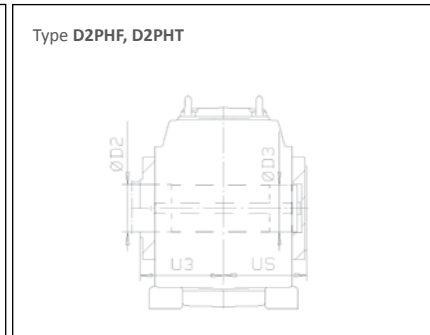

Hollow shaft, key connection, page 12.10

Common accessories, see section 12

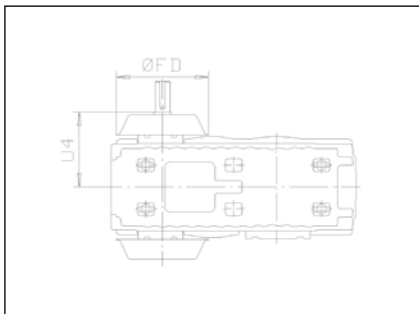

Fan, page 12.21

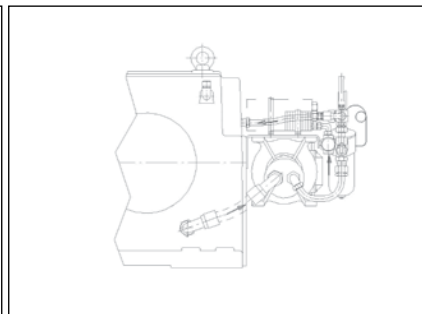

Lubrication unit, page 12.23

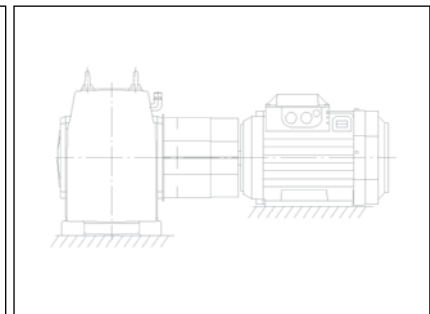

Coupling guard, page 12.31

Size	LSS dimensions in mm															Common accessories	
	Solid shaft					Hollow shaft										U4	FD
	d2	b2	h2	m2	Y2	U2	V2	UD	U3	UC	D4	D5	US	D2	D3		
50	140m6	36h9	148	M30	200	232	432	216	228	336	155	154	232	150	149	355	443
60	160m6	40h9	169	M30	240	261	501	243	255	386	180	179	259	170	169	372	443
70	180m6	45h9	190	M30	240	281	521	272	284	422	190	189	288	190	189	423	547
80	200m6	45h9	210	+))	280	315	595	290	302	453	210	209	306	210	209	443	547
90	220m6	50h9	231	+))	280	337	617	312	324	501	250	249	328	240	239	466	547

In case of through going LSS, same dimensions apply.

+) M20,2x180° distance 0.6xd2

Other available accessories, see section 12

Accessories	Page
Lubrication and cooling	Page
Cooling coil system	12.22
Shaft end pump	12.24
Central lubrication systems connections	12.25
Oil heating system	12.27
Optional seal arrangements	12.30
Lip seal on HSS and LSS	2)

Accessories	Page
Through going HSS	12.16
Coupled equipment	Page
Couplings	*)
Torque arm	12.31
Belt drive	12.32
Back stop	12.33

2) Standard solution for this gear unit type
*) Contact Santasalo

When bath lubrication (+) is used, lip seal is required

See also modifications, page 12.35-12.37

2-stage helical gear units, horizontal LSS

Gear unit dimensions, type D2PSF

Foot mounting face machined for foot mounting, type D2PSF

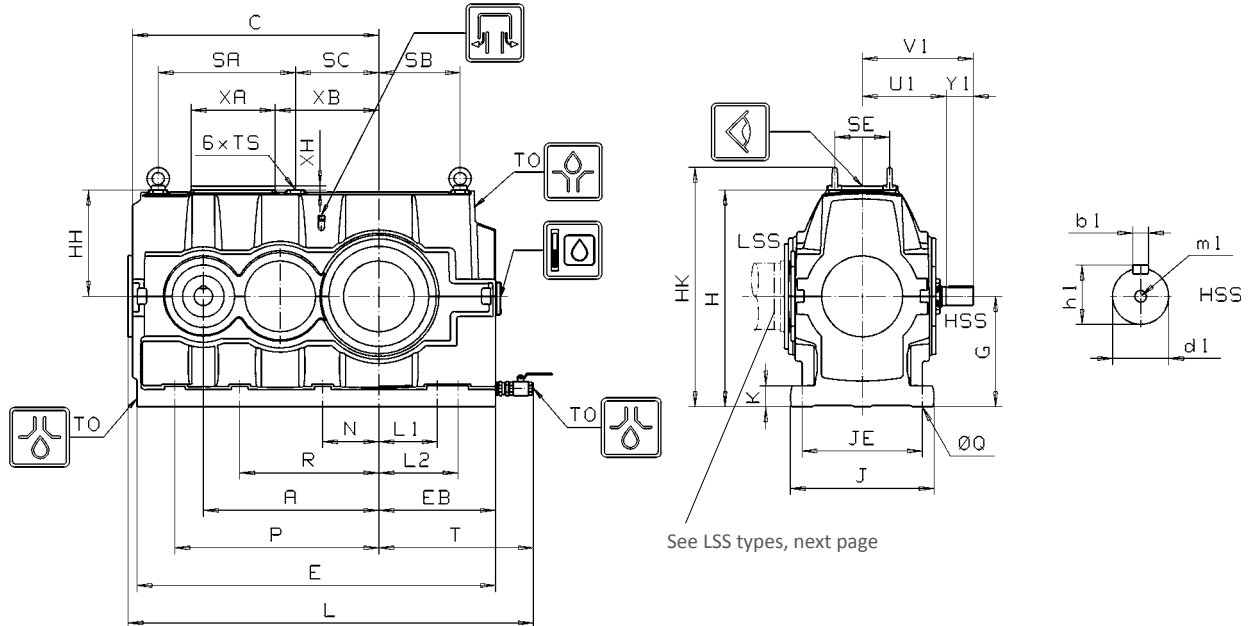

Size	Housing dimensions in mm																			Foot mounting Type D2PSF D2PHF								
	A	C	E	EB	G	H	HH	HK	J	K	L	SA	SB	SC	SE	T	TO	TS	XA	XB	XH	JE	L1	L2	N	P	Q	R
95	808	1073	1573	500	500	980	480	1090	640	75	1772	0	360	995	265	861.5	1 1/2"	M30	403	438.5	32	535	0	410	335	655	42	0
100	874	1216	1753	560	540	1050	510	1159	690	100	1951	741	390	350	265	735	1 1/2"	M30	403	498.5	32	580	300	420	300	1030	48	710
110	965	1310	1870	620	570	1120	560	1130	750	95	2105	0	0	0	795	1 1/2"	0	403	550	32	640	340	480	340	1150	54	770	
120	1072	1554	2234	680	610	1210	600	1357	812	101	2409	970	300	380	320	855	1 1/2"	M42	403	478	32	690	340	540	340	1340	54	856
130	1152	1650	2356	730	680	1330	650	1477	858	103	2555	1070	300	380	360	905	1 1/2"	M42	403	467	32	740	390	590	390	1450	54	935
140	1244	1756	2560	830	730	1430	700	1577	924	110	2761	1120	280	420	400	1005	1 1/2"	M42	403	898	32	794	300	575	394	1500	54	1002
150	1328	1825	2595	809	770	1510	740	1678	952	110	2809	1070	255	535	420	984	1 1/2"	M48	403	818	32	822	300	620	428	1600	54	1070
160	1435	1946	2793	850	820	1600	780	1768	993	110	2971	1190	275	535	450	1025	1 1/2"	M48	403	1018	32	862	300	670	470	1700	54	1150

Size	Housing dimensions in mm								Weight	Oil Capacity	
	D2PSF									kg	l
	U1	Y1	V1	d1	b1	h1	m1	i _N =5.6...18	Splash lubrication		
95	384	190	574	120m6	32h9	127	M24	3400	155	125	
100	380	225	605	130m6	32h9	137	M24	3900	190	153	
110	405	225	630	140m6	36h9	148	M30	5150	237	212	
120	436	225	661	150m6	36h9	158	M30	6690	325	298	
130	468	270	738	160m6	40h9	169	M30	8110	447	415	
140	507	270	777	170m6	40h9	179	M30	9990	571	530	
150	531	270	801	180m6	45h9	190	M30	11480	682	637	
160	561	315	876	210m6	50h9	221	M20(1	13590	788	727	

1) 2 x 180°, distance 0,6 x d2

Shaft Positions

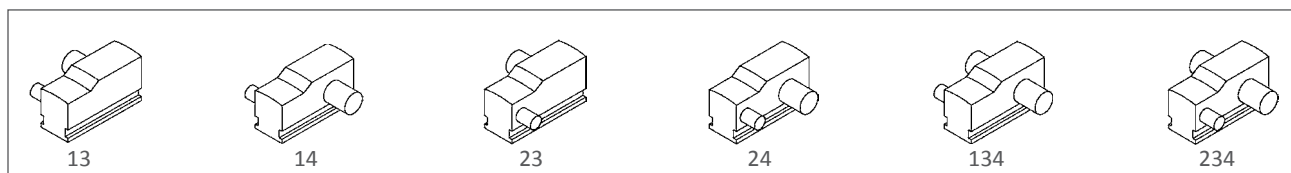

2-stage helical gear units, horizontal LSS

LSS types

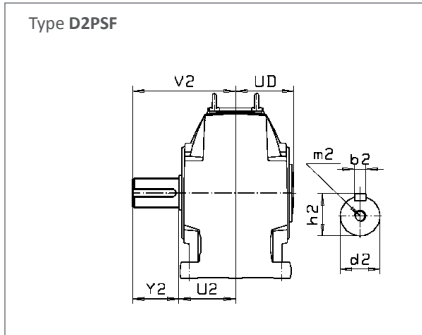

Solid shaft

Common accessories, see section 12

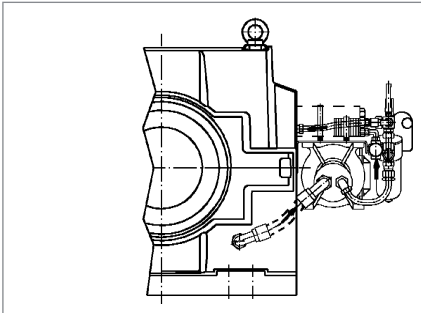

Lubrication unit, page 12.23

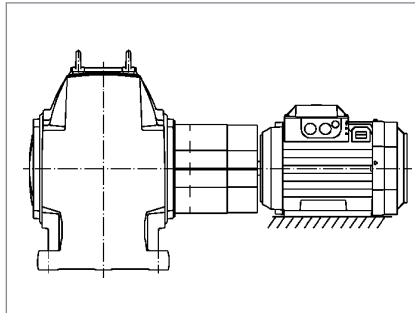

Coupling guard, page 12.31

Size	LSS dimensions in mm							
	Solid shaft							
	d2	b2	h2	m2 1)	Y2	U2	V2	US
100	310m6	70h9	324	M24	380	391	771	361
110	330m6	70h9	344	M30	380	416	796	386
120	350m6	80h9	365	M30	450	447	897	416
130	370m6	80h9	385	M30	450	479	929	451
140	390m6	90h9	407	M30	540	510	1050	482
150	410m6	90h9	427	M30	540	534	1074	495
160	430m6	90h9	447	M30	540	564	1104	525

In case of through going LSS, same dimensions apply.

1) 2 x 180°, distance 0,6 x d2

Other available accessories, see section 12

Accessories	Page
Lubrication and cooling	Page
Shaft end pump	12.24
Oil heating system	12.27
Optional seal arrangements	12.30
Labyrinth seal on HSS and LSS	2)

Through going HSS	12.16
Coupled equipment	Page
Couplings	*)
Torque arm	12.31

2) Standard solution for this gear unit type
*) Contact Santasalo

When bath lubrication (+) is used, lip seal is required

See also modifications, page 12.35-12.37

2-stage helical gear units, horizontal LSS

Gear unit dimensions, type D2PHT

Torque arm mounting bracket with unmachined foot plane, type D2PHT

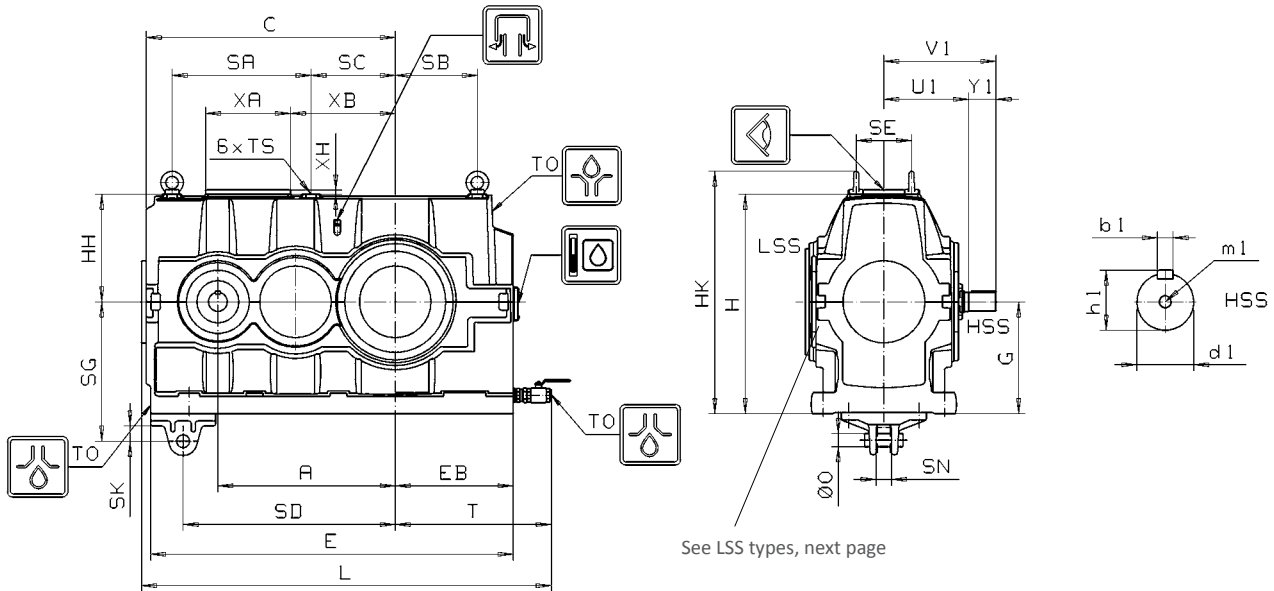

Size	Housing dimensions in mm																		Torque arm mounting bracket					
	A	C	E	EB	G	H	HH	HK	L	SA	SB	SC	SE	T	TO	TS	XA	XB	XH	O	SD	SG	SK	SN
100	874	1216	1753	560	540	1050	510	1159	1951	741	390	350	265	735	1 1/2"	M30	403	498.5	32	63	1000	645	75	70
110	965	1310	1870	620	550	1100	560	1110	2105	0	0	0	0	795	1 1/2"	0	403	550	32	63	1080	670	75	70

Size	HSS dimensions in mm															Oil capacity	
	D2PHT								D2PHT							Splash lubrication	Pressure lubrication
	$i_N=6.3...12.5$								$i_N=14...18$								
U1	Y1	V1	d1	b1	h1	m1	Weight	Y1	V1	d1	b1	h1	m1	Weight	l	l	
100	380	225	605	130	32h9	137	M24	3620	190	570	120	32h9	127	M24	3370	190	153
110	405	225	630	140	36h9	148	M30	4550	225	630	130	32h9	137	M24	4300	237	212

Shaft Positions

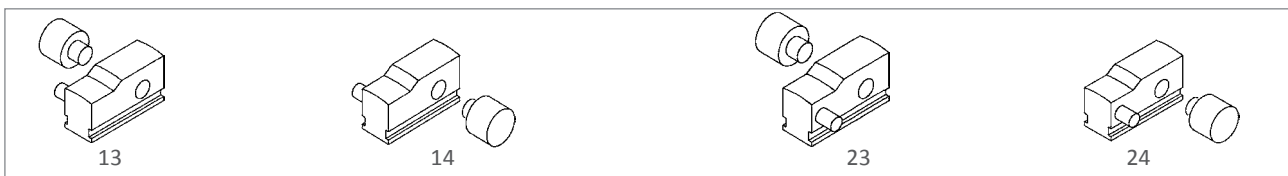

2-stage helical gear units, horizontal LSS

LSS types

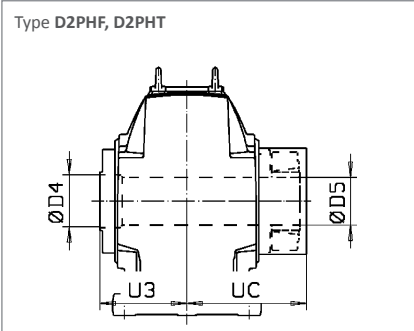

Hollow shaft, shrink disk, page 12.08

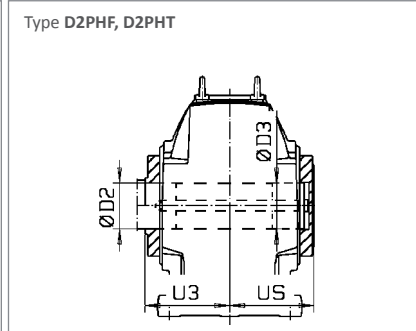

Hollow shaft, key connection, page 12.11

Common accessories, see section 12

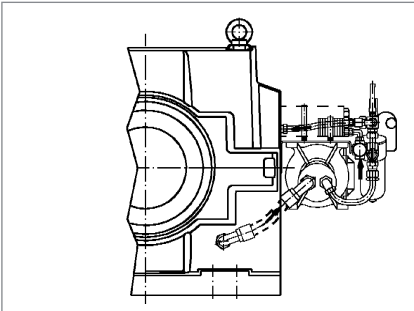

Lubrication unit, page 12.23

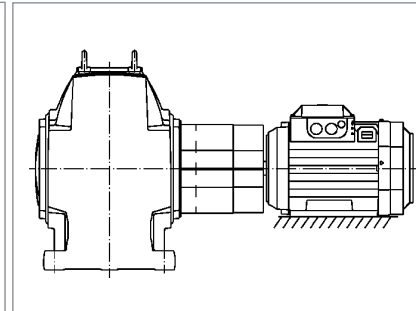

Coupling guard, page 12.31

Size	LSS dimensions in mm						
	Hollow shaft					ØD2	ØD3
	U3	UC	ØD4	ØD5	US		
100	376	570	300	299	361	280	279
110	401	600	320	319	388	290	289

In case of through going LSS, same dimensions apply.

Other available accessories, see section 12

Lubrication and cooling	Page
Shaft end pump	12.24
Oil heating system	12.27
Optional seal arrangements	12.30
Labyrinth seal on HSS and LSS	2)

Through going HSS	12.16
Coupled equipment	Page
Couplings	*)
Torque arm	12.31

See also modifications, page 12.35-12.37

2) Standard solution for this gear unit type
*) Contact Santasalo

When bath lubrication (+) is used, lip seal is required

3-stage helical gear units

Gear unit dimensions, type 3C140N-250N

Foot mounting face machined for foot mounting

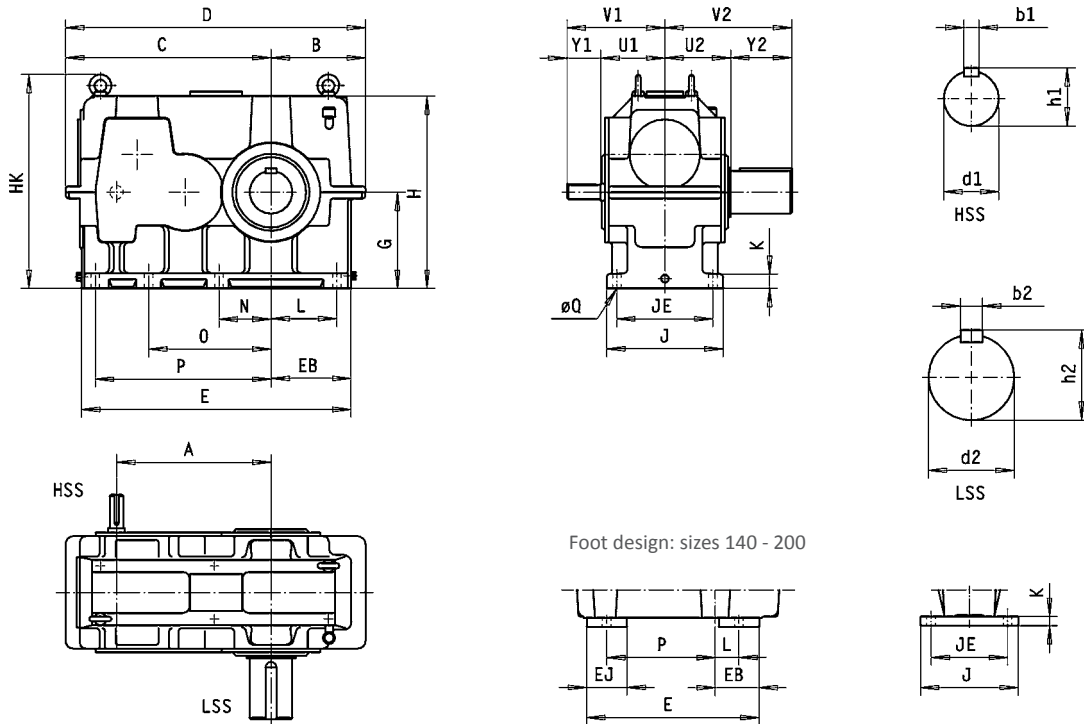

Foot design: sizes 140 - 200

Size	Gear dimensions in mm																	
	A	B	C	D	E	EB	EJ	G	H	HK	J	JE	K	L	N	O	P	Q
140N	250	160	355	515	409	104	114	200	380	433	220	182	20	46	-	-	248	19
160N	285	175	404	579	468	113	125	225	425	478	260	210	25	50	-	-	292	24
180N	320	205	450	655	521	131	140	250	475	537	280	225	25	60	-	-	320	24
200N	360	225	500	725	582	152	150	280	530	592	320	250	30	77	-	-	355	28
225N	405	255	555	810	692	200	-	280	560	631	325	265	40	165	135	-	455	28
250N	450	281	606	887	771	225	-	280	560	631	355	286	45	192	145	-	510	28

Size	Shaft dimensions in mm																		Weight kg	Quantity of oil l
	Input shaft											Output shaft								
	U1	Y1	$i_N=21...47$				$i_N=47...95$				U2	Y2	V2	d2	b2	h2				
140N	117	60	177	25k6	8h9	28	50	167	22k6	6h9	24.5	120	105	225	65m6	18h9	69	105	6.5	
160N	135	60	195	28k6	8h9	31	60	195	25k6	8h9	28	140	105	245	75m6	20h9	79.5	145	9	
180N	143	80	223	30k6	8h9	33	60	203	28k6	8h9	31	145	130	275	85m6	22h9	90	200	12	
200N	153	80	233	32k6	10h9	35	80	233	30k6	8h9	33	155	130	285	95m6	25h9	100	280	17	
225N	172	80	252	35k6	10h9	38	80	252	32k6	10h9	35	175	165	340	110m6	28h9	116	380	30	
250N	190	110	300	40k6	12h9	43	80	270	35k6	10h9	38	195	165	360	120m6	32h9	127	510	40	

Shaft Positions

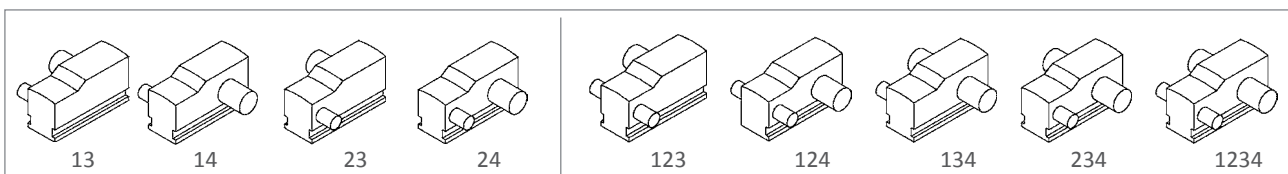

3-stage helical gear units

Gear unit dimensions, type 3TC140N-250N

Torque arm mounting bracket with unmachined foot plane

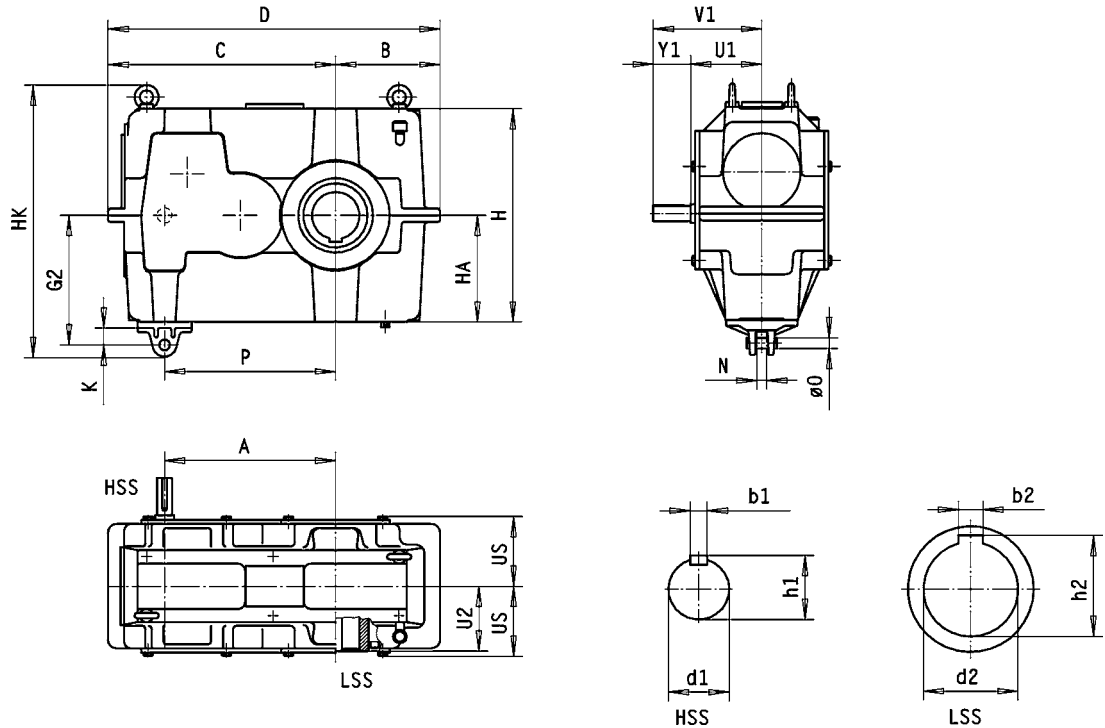

The dimensions of the hollow shaft hole: Page 12.01

Size	Gear dimensions in mm												
	A	B	C	D	G2	H	HA	HK	K	N	O	P	US
140N	250	160	355	515	223	360	180	481	28	20	22h9	250	114
160N	285	175	404	579	243	400	200	521	28	20	22h9	285	131
180N	320	205	450	655	273	450	225	585	28	20	22h9	320	139
200N	360	225	500	725	298	500	250	635	28	20	22h9	360	149
225N	405	255	555	810	343	560	280	729	38	32	32h9	405	167
250N	450	281	606	887	346	560	280	729	38	32	32h9	450	187

Size	Shaft dimensions in mm														Weight kg	Quantity of oil l	
	Input shaft							Hollow shaft									
	$i_N=21...47$							$i_N=47...95$									
	U1	Y1	V1	d1	b1	h1	Y1	V1	d1	b1	h1	U2	d2	b2	h2		
140N	117	60	177	25k6	8h9	28	50	167	22k6	6h9	24.5	100	70H8	20JS9	74.9	105	6.5
160N	135	60	195	28k6	8h9	31	60	195	25k6	8h9	28	118	80HB	22JS9	85.4	145	9
180N	143	80	223	30k6	8h9	33	60	203	28k6	8h9	31	125	90H8	25JS9	95.4	200	12
200N	153	80	233	32k6	10h9	35	80	233	30k6	8h9	33	135	100HB	28JS9	106.4	280	17
225N	172	80	252	35k6	10h9	38	80	252	32k6	10h9	35	154	110H8	28JS9	116.4	380	23
250N	190	110	300	40k6	12h9	43	80	270	35k6	10h9	38	172	120H8	32JS9	127.4	510	26

Shaft Positions

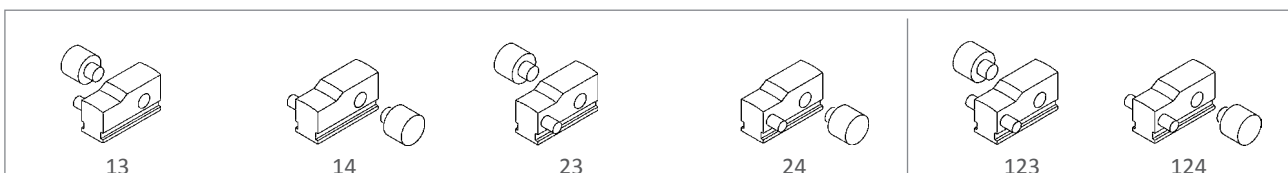

3-stage helical gear units, horizontal LSS

Gear unit dimensions, type D3PSF D3PHF D3PHT

Foot mounting face machined for foot mounting, type D3PSF D3PHF

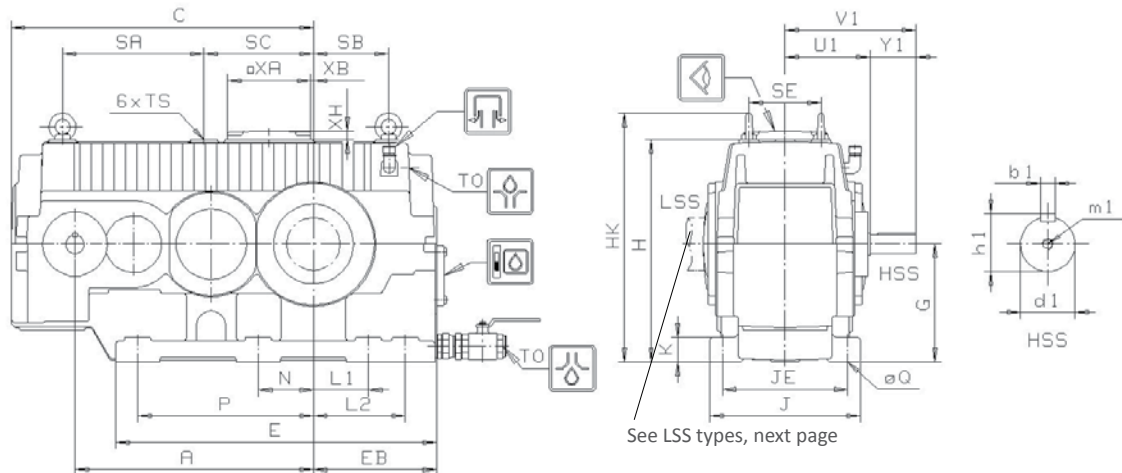

Torque arm mounting bracket with unmachined foot plane, type D3PHT

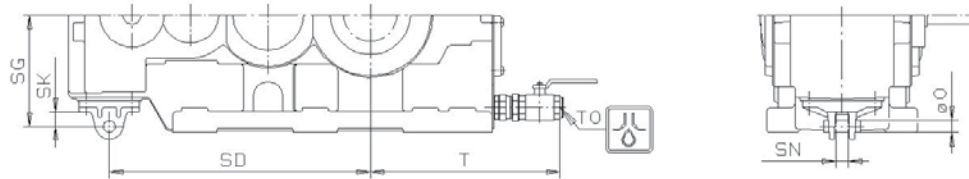

Size	Housing dimensions in mm																			Foot mounting Type D3PSF D3PHF					
	A	C	E	EB	G	H	HK	J	K	SA	SB	SC	SE	TS	TO	T	XA	XB	XH	JE	L1	L2	N	P	Q
50	628	796	846	325	310	585	656	396	65	373	198	288	188	M20x35	R1 1/2	500	220	7	30	330	148	245	145	463	28
60	715	884	974	373	350	665	755	460	73	420	245	325	216	M24x42	R1 1/2	548	220	40	30	378	170	300	168	533	35
70	828	1038	1135	427	400	760	850	506	82	475	292	418	250	M24x42	R1 1/2	602	260	92	30	416	194	322	190	633	35
80	878	1089	1230	470	440	835	944	552	90	541	328	395	280	M30x53	R1 1/2	645	260	62	30	454	209	369	209	666	42
90	972	1217	1324	512	480	910	1019	584	97	531	361	525	305	M20x53	R1 1/2	687	260	192	30	480	228	418	228	719	42

Size	Housing dimensions in mm								Torque arm mounting bracket Type D3PHT					Weight kg	Oil Capacity	
	D2PSF				$i_n=20...90$				O	SD	SG	SK	SN		Splash lubrication	Pressure lubrication
	U1	Y1	V1	d1	b1	h1	m1	l						l		
50	226	95	321	50k6	14h9	53.5	M16	32	693	294	38	32	835	57	32	
60	251	95	346	55m6	16h9	59	M20	45	775	308	52	45	1200	83	50	
70	280	125	405	65m6	18h9	69	M20	45	928	380	52	45	1675	125	73	
80	300	125	425	70m6	20h9	74.5	M20	45	978	380	52	45	2100	160	97	
90	322	150	472	80m6	22h9	85	M20	45	1107	389	52	45	2770	208	123	

Shaft Positions

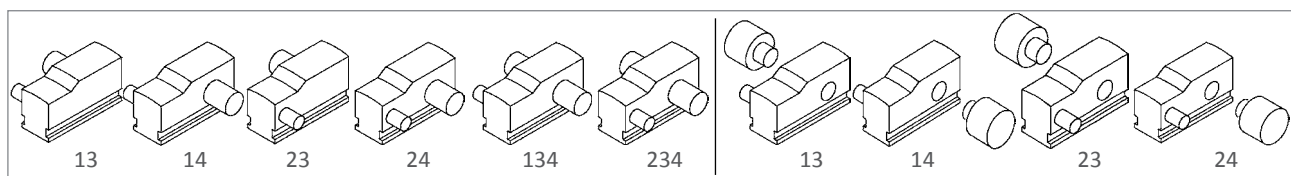

3-stage helical gear units, horizontal LSS

LSS types

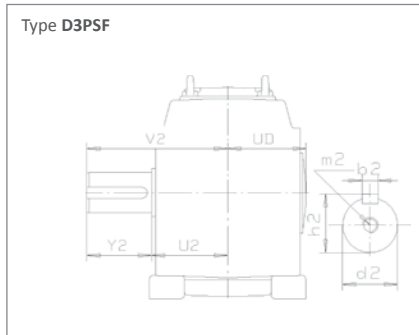

Solid shaft

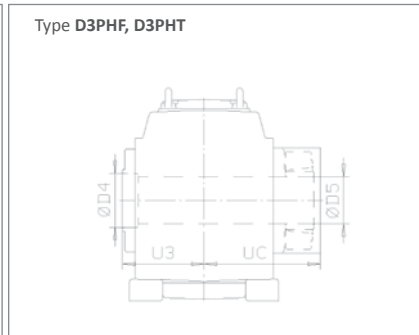

Hollow shaft, shrink disk, page 12.07

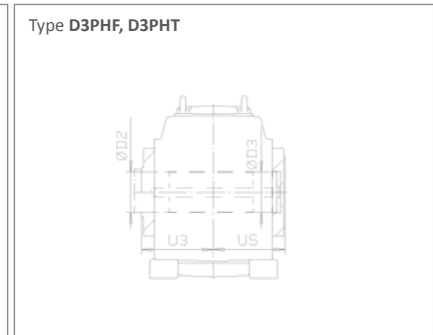

Hollow shaft, key connection, page 12.10

Common accessories, see section 12

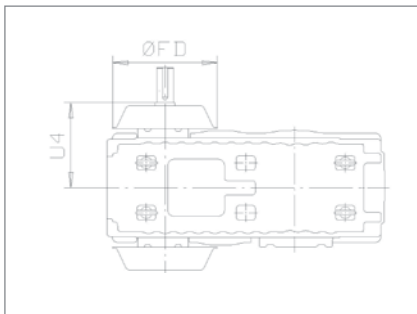

Fan, page 12.21

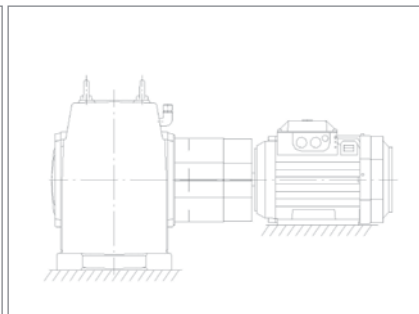

Coupling guard, page 12.31

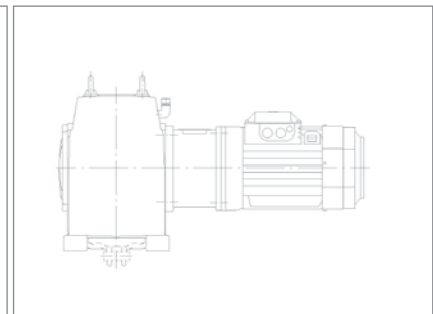

Motor flange, page 12.32

Size	LSS dimensions in mm															Common accessories	
	d2	b2	h2	m2	Y2	U2	V2	UD	U3	UC	D4	D5	US	D2	D3	U4	FD
50	140m6	36h9	148	M30	200	232	432	216	228	336	155	154	232	150	149	343	443
60	160m6	40h9	169	M30	240	261	501	245	255	386	180	179	259	170	169	367	443
70	180m6	45h9	190	M30	240	281	521	274	284	422	190	189	288	190	189	417	547
80	200m6	45h9	210	*)	280	315	595	290	302	453	210	209	306	210	209	435	547
90	220m6	50h9	231	*)	280	337	617	314	324	501	250	249	328	240	239	457	547

Other available accessories, see section 12

Lubrication and cooling	Page
Cooling coil system	12.22
Lubrication unit	12.23
Shaft end pump	12.24
Central lubrication system connections	12.25
Oil heating system	12.27
Optional seal arrangements	12.30
Labyrinth seal on HSS and LSS	2)

Through going HSS	12.16
Coupled equipment	Page
Couplings	*)
Torque arm	12.31
Belt drive	12.32
Back stop	12.33

See also modifications, page 12.35-12.37

2) Standard solution for this gear unit type
*) Contact Santasalo

3-stage helical gear units, horizontal LSS

Gear unit dimensions, type D3PSF D3PHF

Foot mounting face machined for foot mounting

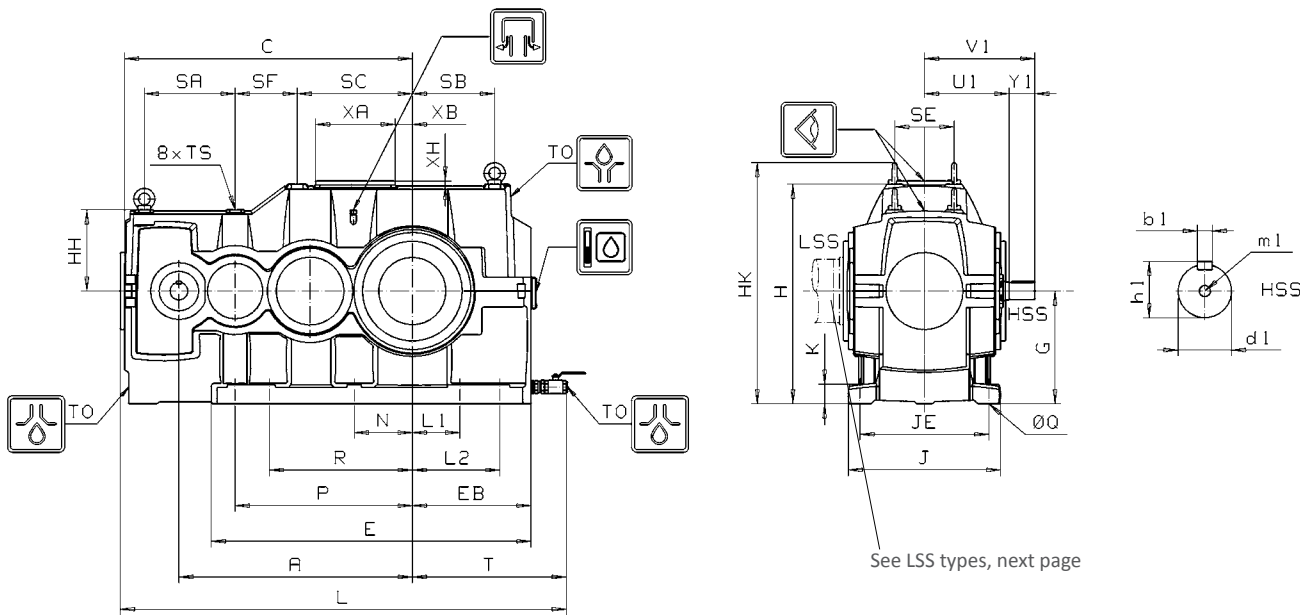

Size	Housing dimensions in mm																						
	A	C	E	EB	G	H	HH	HK	J	JX	K	L	SA	SB	SC	SE	SF	T	TO	TS	XA	XB	XH
100	1116	1386	1496	560	540	1050	375	1159	690	380	100	2121	435	391	570	265	281	735	1 1/2	M30	403	58	32
110	1233	1510	1658	620	570	1130	410	1258	750	418	100	2305	480	440	640	290	290	795	1 1/2	M36	403	86	32
120	1366	1700	1836	680	610	1200	465	1328	810	450	103	2555	535	485	695	320	355	855	1 1/2	M36	403	129	32
130	1475	1815	1984	730	680	1330	489	1477	860	506	103	2720	580	530	760	360	360	905	1 1/2	M42	403	129	32
140	1593	1973	2115	780	730	1440	520	1587	914	554	110	2928	630	580	810	420	410	955	1 1/2	M42	403	129	32
150	1707	2052	2357	750	770	1525	755	1557	942	-	95	2977	0	0	0	0	0	925	1 1/2	0	403	608	32
160	1840	2230	2540	800	820	1630	810	1662	1002	-	95	3205	0	0	0	0	0	975	1 1/2	0	403	665	32

Size	HSS dimensions in mm								Foot mounting								Weight D3PSF/D3PHF kg	Oil Capacity	
	$i_n=20...90$																	Splash lubrication l	Pressure lubrication l
	U1	Y1	V1	d1	b1	h1	m1		JE	L1	L2	N	P	Q	R				
100	374	150	524	90m6	25h9	95	M24	580	300	420	300	850	48	730	4260/3730	285	130		
110	399	150	549	95m6	25h9	100	M24	640	340	480	340	950	54	770	5410/4800	370	155		
120	430	190	620	100m6	28h9	106	M24	690	340	540	340	1060	54	880	7110/6400	490	195		
130	462	190	652	110m6	28h9	116	M24	740	390	590	390	1135	54	935	8770/8130	635	235		
140	504	190	694	120m6	32h9	127	M24	794	440	660	394	1234	54	1234	10880/9810	830	290		
150	528	225	753	130m6	32h9	137	M24	822	300	620	428	1476	54	1156	13180/12340	1010	320		
160	558	225	783	140m6	36h9	148	M30	862	300	670	470	1610	54	1240	15350/14400	1220	380		

Shaft Positions

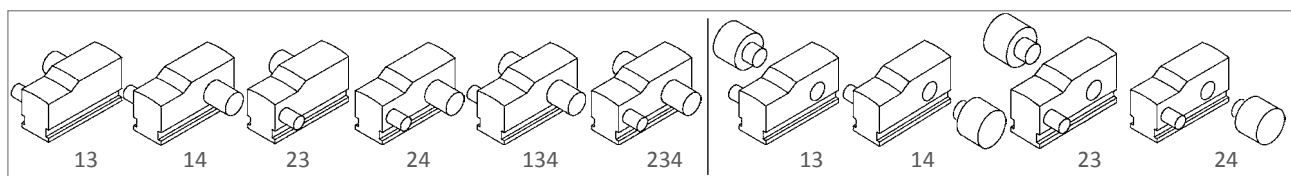

3-stage helical gear units, horizontal LSS

LSS types

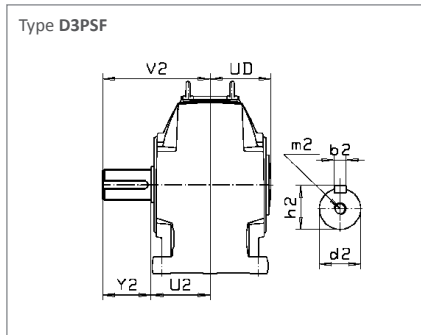

Solid shaft

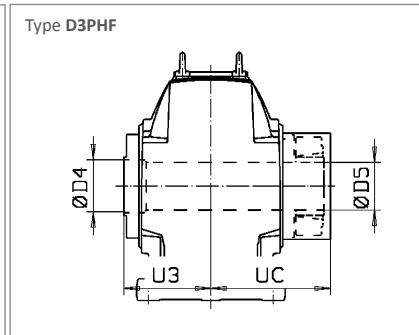

Hollow shaft, shrink disk, page 12.08

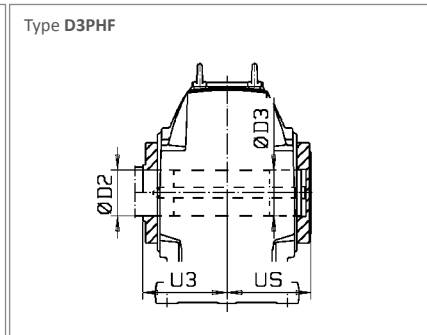

Hollow shaft, key connection, page 12.11

Common accessories, see section 12

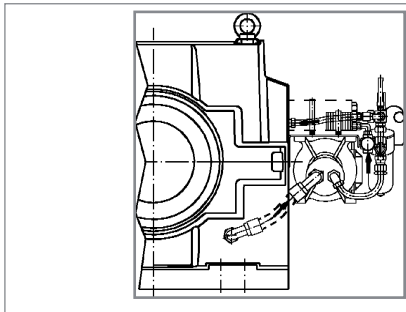

Lubrication unit, page 12.23

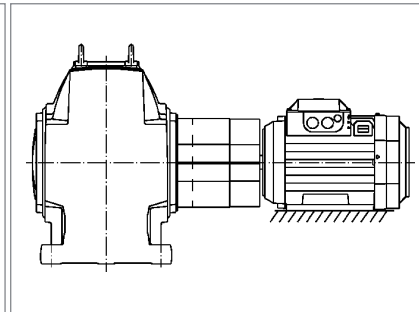

Coupling guard, page 12.31

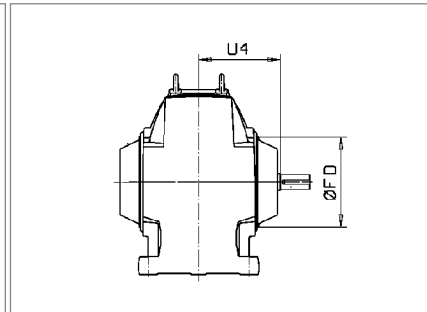

Fan, page 12.21

Size	LSS dimensions in mm																
	Solid shaft						Hollow shaft										
	d2	b2	h2	m2 (t)	Y2	U2	V2	UD	U3	UC	ØD4	ØD5	US	ØD2	ØD3	ØD6	ØD7
100	310m6	70h9	324	M24	380	391	771	361	376	570	300	299	361	280	279	315	279
110	330m6	70h9	344	M30	380	416	796	386	401	600	320	319	386	290	289	325	289
120	350m6	80h9	365	M30	450	447	897	416	432	650	330	329	416	300	299	340	299
130	370m6	80h9	385	M30	450	479	929	451	464	690	380	379	446	340	339	385	339
140	390m6	90h0	407	M30	540	510	1050	482	495	745	400	399	481	360	359	400	359
150	410m6	90h9	427	M30	540	534	1074	506	519	800	450	449	501	400	399	450	399
160	430m6	90h9	447	M30	540	564	1104	536	549	830	460	459	531	420	419	465	419

In case of through going LSS, same dimensions apply.

1) 2x180° distance 0.6 x d2

Other available accessories, see section 12

Lubrication and cooling	Page
Shaft end pump	12.24
Oil heating system	12.27
Optional seal arrangements	12.31
Labyrinth seal on HSS and LSS	2)

Through going HSS	12.16
Coupled equipment	Page
Couplings	*)

See also modifications, page 12.35-12.37

2) Standard solution for this gear unit type
*) Contact Santasalo

When bath lubrication (+) is used, lip seal is required

3-stage helical gear units, horizontal LSS

Gear unit dimensions, type D3PHT

Torque arm mounting bracket with unmachined foot plane

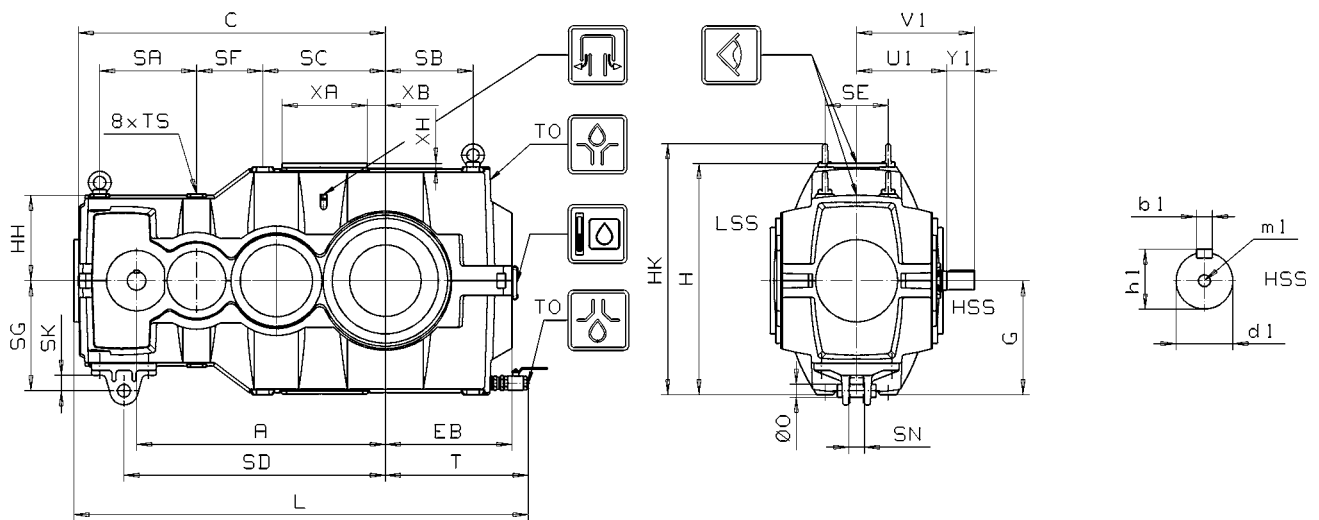

Size	Housing dimensions in mm																		
	A	C	EB	G	H	HH	HK	L	SA	SB	SC	SE	SF	T	TO	TS	XA	XB	XH
100	1116	1386	560	510	1020	375	1129	2016	435	391	570	265	281	630	1 1/2"	M30	403	58	32
110	1233	1510	620	560	1120	410	1248	2200	480	440	640	290	290	690	1 1/2"	M36	403	86	32
120	1366	1700	680	590	1180	465	1308	2445	535	485	695	320	355	745	1 1/2"	M36	403	129	32
130	1475	1815	730	650	1300	489	1447	2610	580	530	760	360	360	795	1 1/2"	M42	403	129	32
140	1593	1973	780	710	1420	520	1567	2818	630	580	810	420	410	845	1 1/2"	M42	403	129	32
150	1707	2052	750	750	1505	755	1537	2977	0	0	0	0	0	925	1 1/2"	0	403	608	32
160	1840	2230	800	800	1610	810	1642	3205	0	0	0	0	0	975	1 1/2"	0	403	665	32

Size	HSS dimensions in mm							Torque arm mounting bracket						Weight	Oil Capacity	
	$i_n=20...90$							O	SD	SG	SK	SN	kg		Splash	lubrication
	U1	Y1	V1	d1	b1	h1	m1							I	I	
100	374	150	524	90m6	25h9	95	M24	63	1190	470	75	70	3590	210	130	
110	399	150	549	95m6	25h9	100	M24	63	1310	500	75	70	4670	275	155	
120	430	190	620	100m6	28h9	106	M24	63	1475	555	75	70	6230	355	195	
130	462	190	652	110m6	28h9	116	M24	63	1550	586	75	70	7900	560	235	
140	504	190	694	120m6	32h9	127	M24	80	1650	675	120	90	9300	700	250	
150	528	225	753	130m6	32h9	137	M24	80	1767	650	120	90	11790	860	280	
160	558	225	783	140m6	36h9	148	M30	80	1910	700	120	90	13790	1030	320	

Shaft Positions

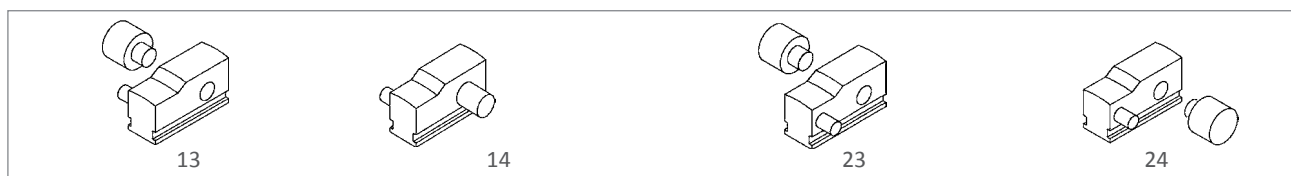

3-stage helical gear units, horizontal LSS

LSS types

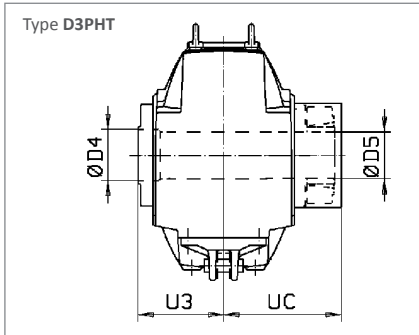

Hollow shaft, shrink disk, page 12.08

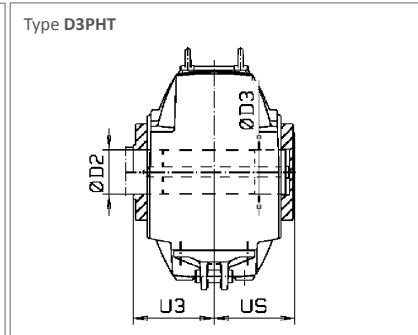

Hollow shaft, key connection, page 12.11

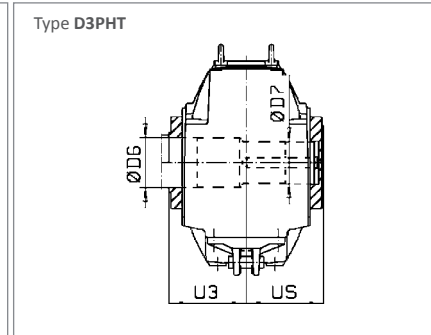

Hollow shaft, special key connection, page 12.12

Common accessories, see section 12

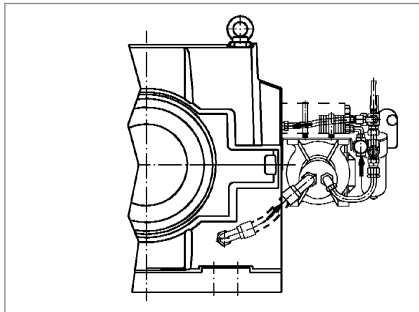

Lubrication unit, page 12.23

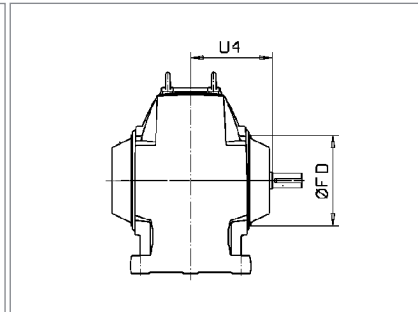

Fan, page 12.21

Size	LSS dimensions in mm								
	Hollow shaft								
	U3	UC	ØD4	ØD5	US	ØD2	ØD3	ØD6	ØD7
100	376	570	300	299	361	280	279	315	279
110	401	600	320	319	386	290	289	325	289
120	432	650	330	329	416	300	299	340	299
130	464	690	380	379	446	340	339	385	339
140	495	745	400	399	481	360	359	400	359
150	519	800	450	449	501	400	399	450	399
160	549	830	460	459	531	420	419	465	419

In case of through going LSS, same dimensions apply.

Other available accessories, see section 12

Lubrication and cooling	Page
Shaft end pump	12.24
Oil heating system	12.27
Optional seal arrangements	12.30
Labyrinth seal on HSS and LSS	2)

Coupled equipment	Page
Couplings	*)
Torque arm	12.31
V-Belt drive	12.32

See also modifications, page 12.35-12.37

2) Standard solution for this gear unit type
*) Contact Santasalo
When bath lubrication (+) is used, lip seal is required

4-stage helical gear units

Gear unit dimensions, type 4C140N-250N

Foot mounting face machined for foot mounting

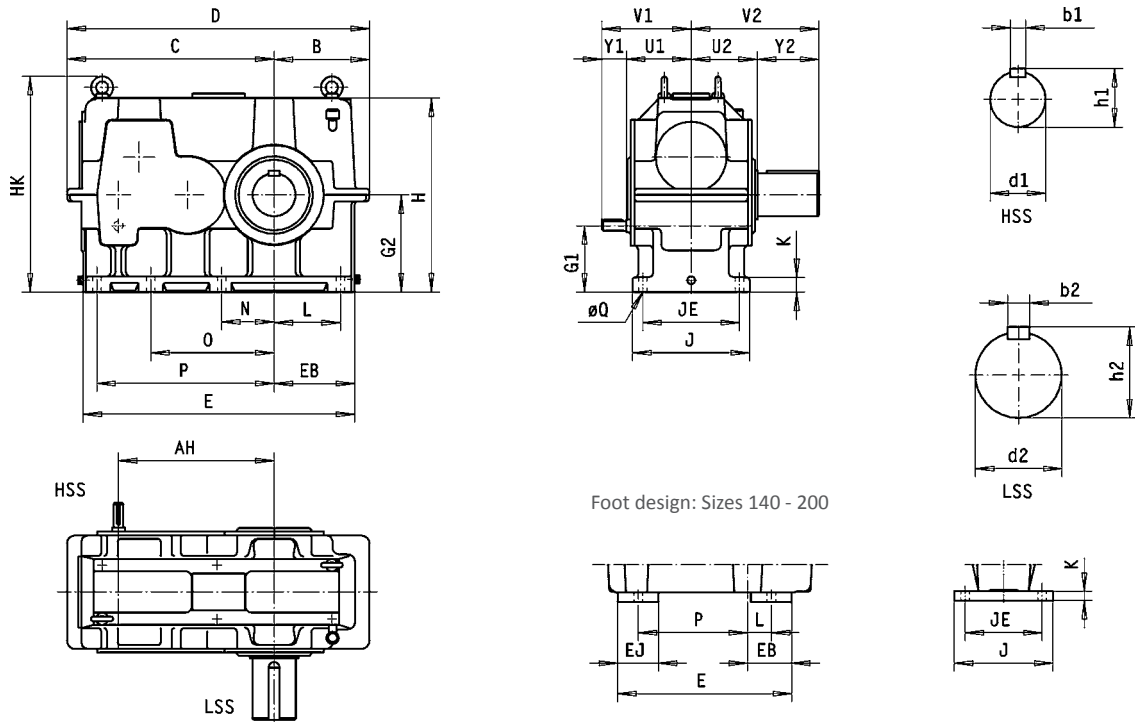

Foot design: Sizes 140 - 200

Size	Gear dimensions in mm													
	AH	AV	B	C	D	G2	H	HA	HK	K	N	O	P	US
140N	250	71	160	355	515	223	360	180	481	28	20	22h9	250	114
160N	285	80	175	404	579	243	400	200	521	28	20	22h9	285	131
180N	320	80	205	450	655	273	450	225	585	28	20	22h9	320	139
200N	360	80	225	500	725	298	500	250	635	28	20	22h9	360	149
225N	405	80	255	555	810	343	560	280	729	38	32	32h9	405	167
250N	450	90	281	606	887	346	560	280	729	38	32	32h9	450	187

Size	Shaft dimensions in mm										Weight kg	Quantity of oil l
	Input shaft					Hollow shaft						
	U1	Y1	V1	d1	b1	h1	U2	d2	b2	h2		
140N	117	40	157	18k6	6h9	20.5	100	70H8	20JS9	74.9	110	6.5
160N	135	50	185	20k6	6h9	22.5	118	80H8	22JS9	85.4	150	9
180N	143	50	193	22k6	6h9	24.5	125	90H8	25JS9	95.4	210	12
200N	153	60	213	25k6	8h9	28	135	100H8	28JS9	106.4	290	17
225N	172	60	232	28k6	8h9	31	154	110H8	28JS9	116.4	390	23
250N	190	80	270	30k6	8h9	33	172	120H8	32JS9	127.4	530	26

Shaft Positions

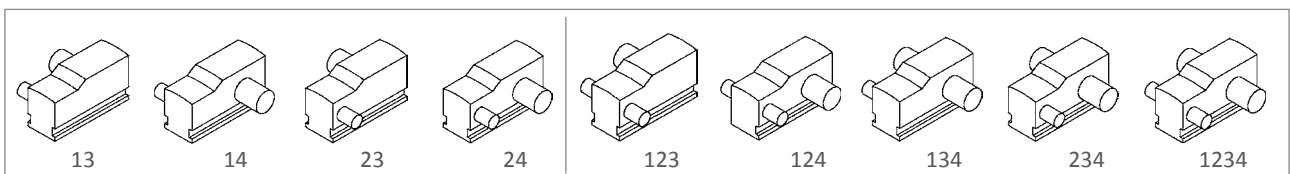

4-stage helical gear units

Gear unit dimensions, type 4TC140N-250N

Torque arm mounting bracket with unmachined foot plane

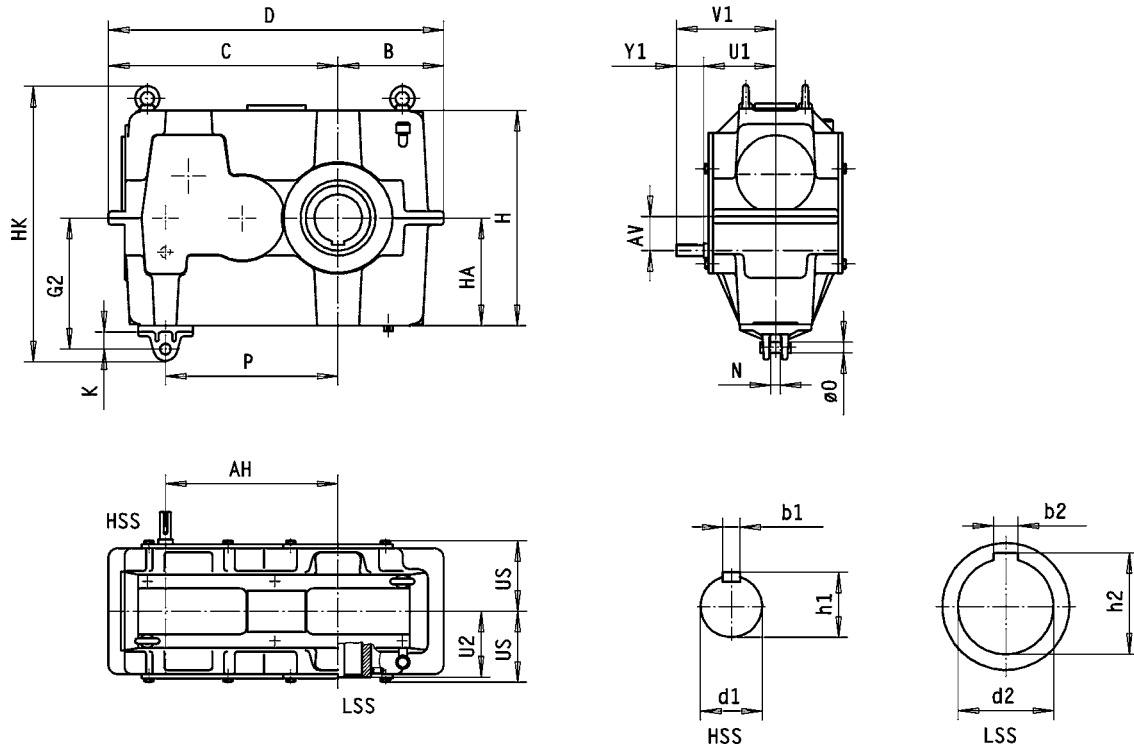

The dimensions of the hollow shaft hole: Page 12.01

Size	Gear dimensions in mm													
	AH	AV	B	C	D	G2	H	HA	HK	K	N	O	P	US
140N	250	71	160	355	515	223	360	180	481	28	20	22h9	250	114
160N	285	80	175	404	579	243	400	200	521	28	20	22h9	285	131
180N	320	80	205	450	655	273	450	225	585	28	20	22h9	320	139
200N	360	80	225	500	725	298	500	250	635	28	20	22h9	360	149
225N	405	80	255	555	810	343	560	280	729	38	32	32h9	405	167
250N	450	90	281	606	887	346	560	280	729	38	32	32h9	450	187

Size	Shaft dimensions in mm										Weight kg	Quantity of oil l
	Input shaft					Hollow shaft						
	U1	Y1	V1	d1	b1	h1	U2	d2	b2	h2		
140N	117	40	157	18k6	6h9	20.5	100	70H8	20JS9	74.9	110	6.5
160N	135	50	185	20k6	6h9	22.5	118	80H8	22JS9	85.4	150	9
180N	143	50	193	22k6	6h9	24.5	125	90H8	25JS9	95.4	210	12
200N	153	60	213	25k6	8h9	28	135	100H8	28JS9	106.4	290	17
225N	172	60	232	28k6	8h9	31	154	110H8	28JS9	116.4	390	23
250N	190	80	270	30k6	8h9	33	172	120H8	32JS9	127.4	530	26

Shaft Positions

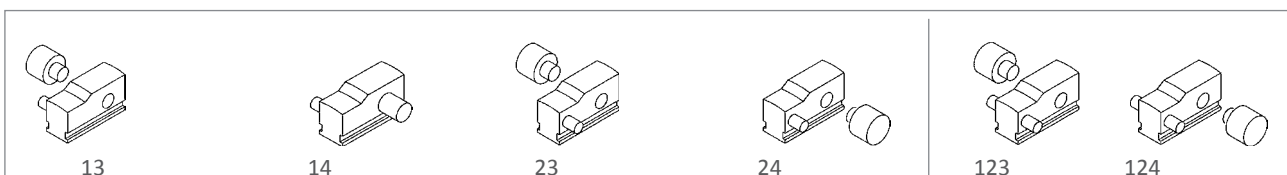

4-stage helical gear units, horizontal LSS

Gear unit dimensions, type D4PSF D4PHF D4PHT

Foot mounting face machined for foot mounting, type D4PSF D4PHF

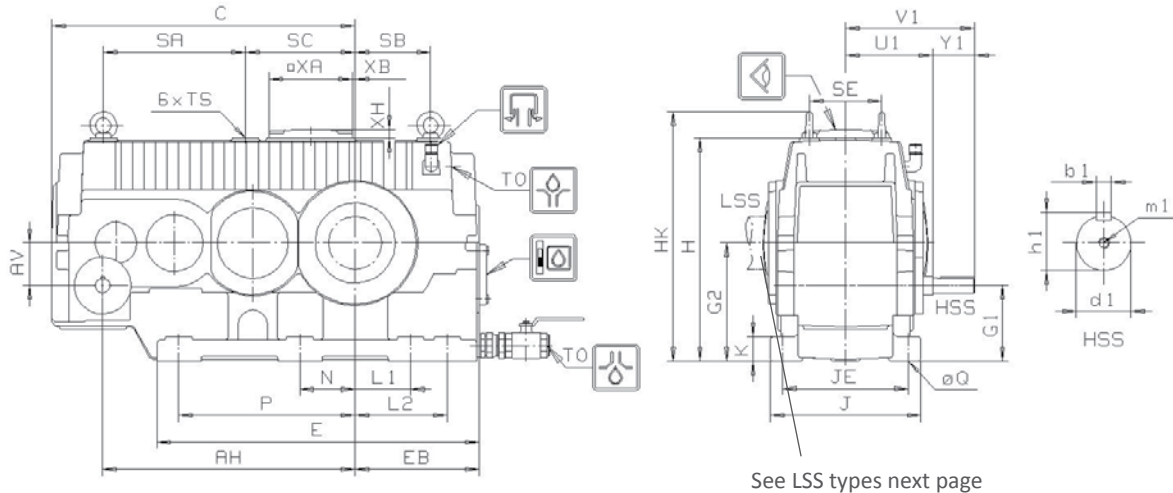

See LSS types next page

Torque arm mounting bracket with unmachined foot plane, type D4PHT

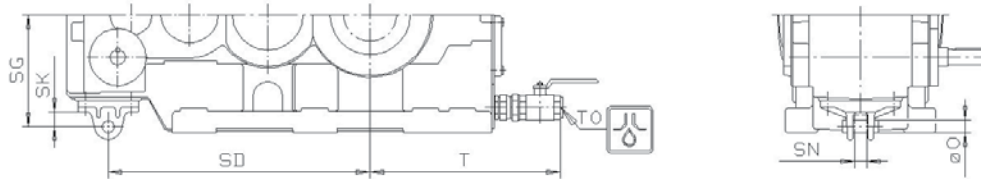

Size	Housing dimensions in mm																				Torque arm mounting bracket Type D4PHT					Foot mounting Type D4PSF D4PHF						
	AH	AV	C	E	EB	G1	G2	H	HK	J	K	SA	SB	SC	SE	TS	TO	T	XA	XB	XH	O	SD	SG	SK	SN	JE	L1	L2	N	P	Q
50	663	111.6	796	846	325	198.4	310	585	656	396	65	373	198	288	188	M20x35	R1 1/2	500	220	7	30	32	693	294	38	32	330	148	245	145	463	28
60	750	111.6	884	974	373	238.4	350	665	755	460	73	420	245	325	216	M24x42	R1 1/2	548	220	40	30	45	775	308	52	45	378	170	300	168	533	35
70	868	148.7	1038	1135	427	251.3	400	760	850	506	82	475	292	418	250	M24x42	R1 1/2	602	260	92	30	45	928	380	52	45	416	194	322	190	633	35
80	918	148.7	1089	1230	470	291.3	440	835	944	552	90	541	328	395	280	M30x53	R1 1/2	645	260	62	30	45	978	380	52	45	454	209	369	209	666	42
90	1047	151.4	1217	1324	512	328.6	480	910	1019	584	97	531	361	525	305	M30x53	R1 1/2	687	260	192	30	45	1107	389	52	45	480	228	418	228	719	42

Size	HSS dimensions in mm																				Oil capacity	
	D4PSF					D4PHF, D4PHT					D4PHF, D4PHT					Weight	Splash lubrication	Pressure lubrication				
	$i_N=100...400$					$i_N=100...225$					$i_N=250...400$											
U1	Y1	V1	d1	b1	h1	m1	Y1	V1	d1	b1	h1	m1	Y1	V1	d1	b1	h1	m1	kg	l	l	
50	217	70	287	35k6	10h9	38	M12	70	287	35k6	10h9	38	M12	70	287	30k6	8h9	33	M10	845	57	57
60	244	95	339	40k6	12h9	43	M16	95	339	40k6	12h9	43	M16	95	339	40k6	12h9	43	M16	1215	83	83
70	273	95	368	45k6	14h9	48.5	M16	95	368	45k6	14h9	48.5	M16	95	368	45k6	14h9	48.5	M16	1700	125	125
80	291	95	386	50k6	14h9	53.5	M16	95	386	50k6	14h9	53.5	M16	95	386	50k6	14h9	53.5	M16	2125	160	160
90	313	125	438	60m6	18h9	64	M20	125	438	60m6	18h9	64	M20	125	438	60m6	18h9	64	M20	2800	208	208

Shaft Positions

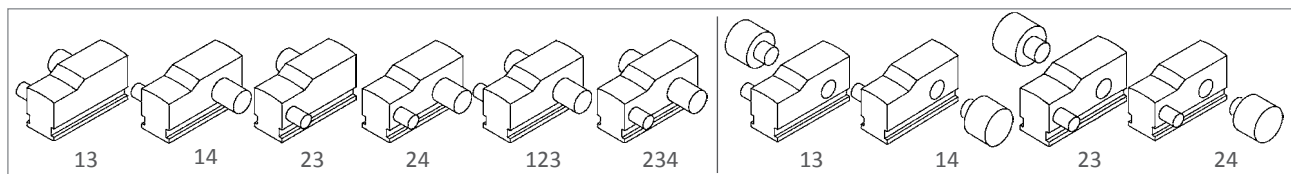

4-stage helical gear units, horizontal LSS

LSS types

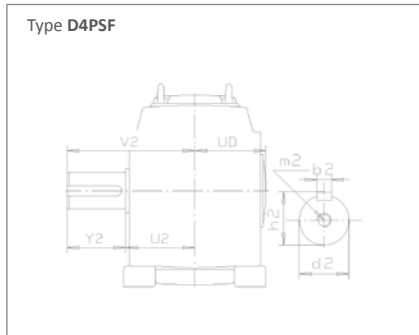

Solid shaft

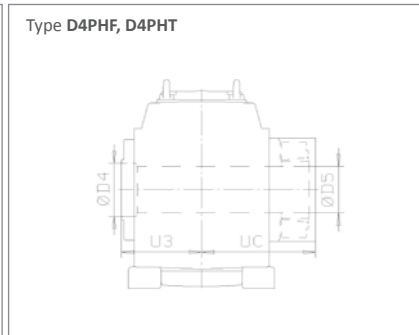

Hollow shaft, shrink disk, page 12.07

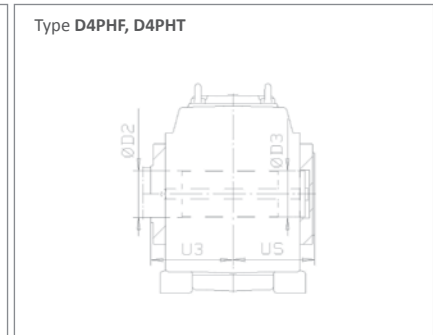

Hollow shaft, key connection, page 12.10

Common accessories, see section 12

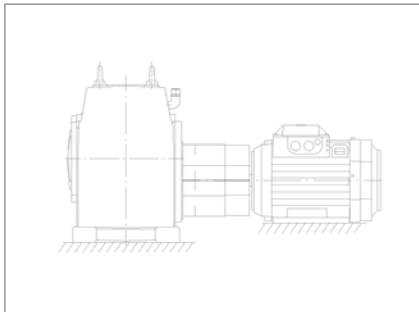

Coupling guard, page 12.31

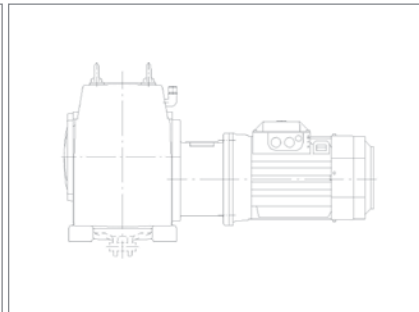

Motor flange, page 12.32

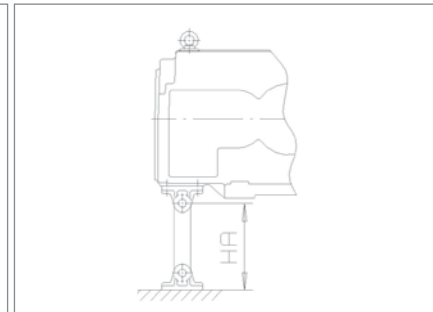

Torque arm, page 12.31

Size	LSS dimensions in mm															Common accessories	
	Solid shaft							Hollow shaft								H Amin	H Max
	d2	b2	h2	m2	Y2	U2	V2	UD	U3	UC	D4	D5	US	D2	D3		
50	140m6	36h9	148	M30	200	232	432	216	228	336	155	154	232	150	149	125	950
60	160m6	40h9	169	M30	240	261	501	245	255	386	180	179	259	170	169	175	1070
70	180m6	45h9	190	M30	240	281	521	274	284	422	190	189	288	190	189	175	1070
80	200m6	45h9	210	+))	280	315	595	290	302	453	210	209	306	210	209	175	1070
90	220m6	50h9	231	+))	280	337	617	314	324	501	250	249	328	240	239	175	1070

In case of through going LSS, same dimensions apply.

+) M20,2x180° distance 0.6xd2

Other available accessories, see section 12

Accessory	Page
Lubrication and cooling	Page
Lubrication unit	12.23
Shaft end pump	12.24
Central lubrication system connections	12.25
Oil heating system	12.27
Optional seal arrangements	12.31
Labyrinth seal on HSS and LSS	2)

Accessory	Page
Through going HSS	12.16
Coupled equipment	Page
Couplings	*)
Belt drive	12.32
Back stop	12.33

2) Standard solution for this gear unit type
*) Contact Santasalo

See also modifications, page 12.35-12.37

4-stage helical gear units, horizontal LSS

Gear unit dimensions, type D4PSF D4PHF

Foot mounting face machined for foot mounting

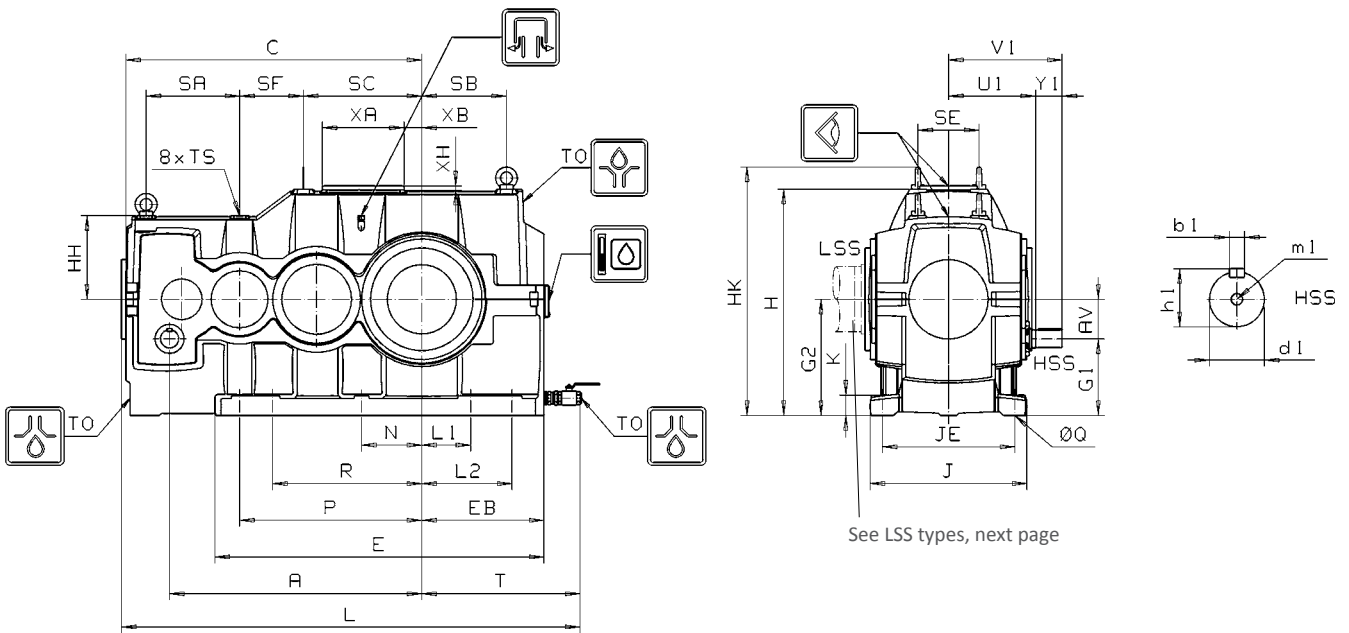

See LSS types, next page

Size	Housing dimensions in mm																							
	A	AV	C	E	EB	G1	G2	H	HH	HK	J	K	L	SA	SB	SC	SE	SF	T	TO	TS	XA	XB	XH
100	1186	176.6	1386	1496	560	363.4	540	1050	375	1159	690	100	2121	435	391	570	265	281	735	1 1/2"	M30	403	58	32
110	1293	193.9	1510	1658	620	376.1	570	1130	410	1258	750	100	2305	480	440	640	290	290	795	1 1/2"	M36	403	86	32
120	1446	202.8	1700	1836	680	407.2	610	1200	465	1328	810	103	2555	535	485	695	320	355	855	1 1/2"	M36	403	129	32
130	1545	224.3	1815	1984	730	453.7	680	1330	489	1477	860	103	2720	580	530	760	360	360	905	1 1/2"	M42	403	129	32
140	1693	230.2	1973	2115	780	499.8	730	1440	520	1587	914	110	2928	630	580	810	420	410	955	1 1/2"	M42	403	129	32
150	1767	264.3	2052	2357	750	505.7	770	1525	755	1557	942	95	2977	0	0	0	0	0	925	1 1/2"	0	403	608	32
160	1910	289.7	2230	2540	800	530.3	820	1630	810	1662	1002	95	3205	0	0	0	0	0	975	1 1/2"	0	403	665	32

Size	HSS dimensions in mm										Weight kg	Oil capacity					
	$i_v=100...400$							Foot mounting				l	l				
	U1	Y1	V1	d1	b1	h1	m1	JE	L1	L2				N	P	Q	R
100	375	125	500	65m6	18h9	69	M20	580	300	420	300	850	48	730	4300/3770	290	130
110	400	125	525	75m6	20h9	79.5	M20	640	340	480	340	950	54	770	5450/4850	380	155
120	431	150	581	80m6	22h9	85	M20	690	340	540	340	1060	54	880	7110/6410	510	195
130	463	150	613	85m6	22h9	90	M20	740	390	590	390	1135	54	935	8840/8210	650	235
140	494	150	644	90m6	25h9	95	M24	794	440	660	394	1234	54	1035	10900/9770	830	290
150	518	150	668	95m6	25h9	100	M24	822	300	620	428	1476	54	1156	13440/12550	1010	320
160	548	190	738	100m6	28h9	106	M24	862	300	670	470	1610	54	1240	15650/14650	1220	380

Shaft Positions

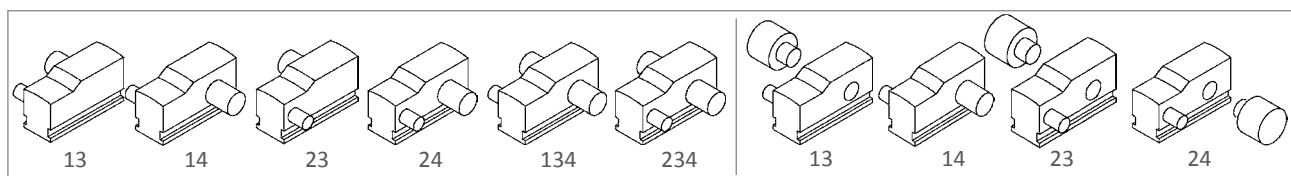

4-stage helical gear units, horizontal LSS

LSS types

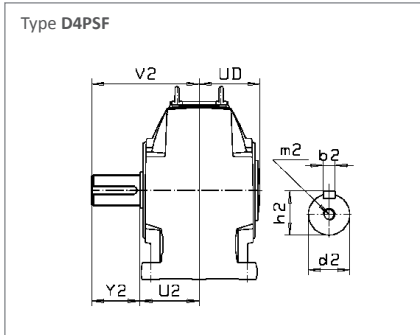

Solid shaft

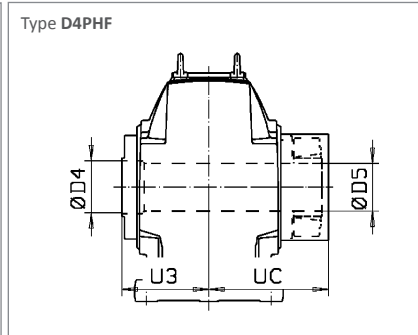

Hollow shaft, shrink disk, page 12.08

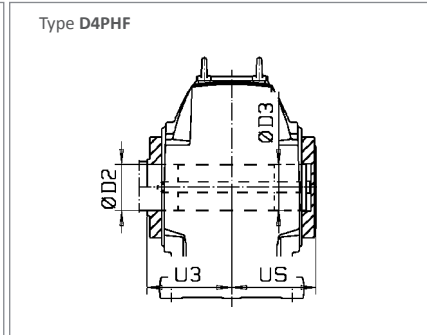

Hollow shaft, key connection, page 12.11

Common accessories, see section 12

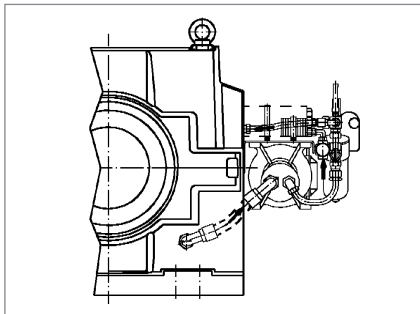

Lubrication unit, page 12.23

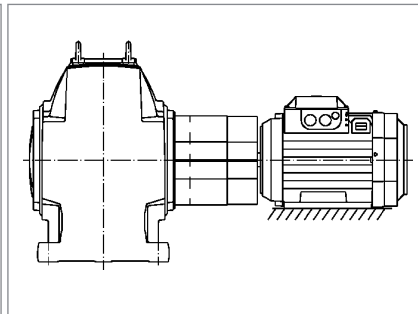

Coupling guard, page 12.31

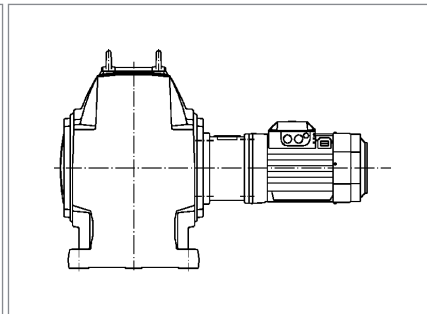

Motor flange, page 12.32

Size	LSS dimensions in mm																
	Solid shaft							Hollow shaft									
	d2	b2	h2	m2 (1)	Y2	U2	V2	UD	U3	UC	ØD4	ØD5	US	ØD2	ØD3	ØD4	ØD6
100	310m6	70h9	324	M24	380	391	771	361	376	570	300	299	361	280	279	315	279
110	330m6	70h9	344	M30	380	416	796	386	401	600	320	319	386	290	289	325	289
120	350m6	80h9	365	M30	450	447	897	416	432	650	330	329	416	300	299	340	299
130	370m6	80h9	385	M30	450	479	929	451	464	690	380	379	446	340	339	385	339
140	390m6	90h9	407	M30	540	510	1050	482	495	745	400	399	481	360	359	400	359
150	410m6	90h9	427	M30	540	534	1074	506	519	800	450	449	501	400	399	450	399
160	430m6	90h9	447	M30	540	564	1104	536	549	830	460	459	531	420	419	465	419

In case of through going LSS, same dimensions apply.

1) 2x180° distance 0.6 x d2

Other available accessories, see section 12

Lubrication and cooling	Page
Shaft end pump	12.24
Oil heating system	12.27
Optional seal arrangements	12.30
Labyrinth seal on HSS and LSS	2)

Through going HSS	12.16
Coupled equipment	Page
Couplings	*)
Belt drive	12.32

2) Standard solution for this gear unit type
*) Contact Santasalo

See also modifications, page 12.35-12.37

4-stage helical gear units, horizontal LSS

Gear unit dimensions, type D4PHT

Torque arm mounting bracket with unmachined foot plane

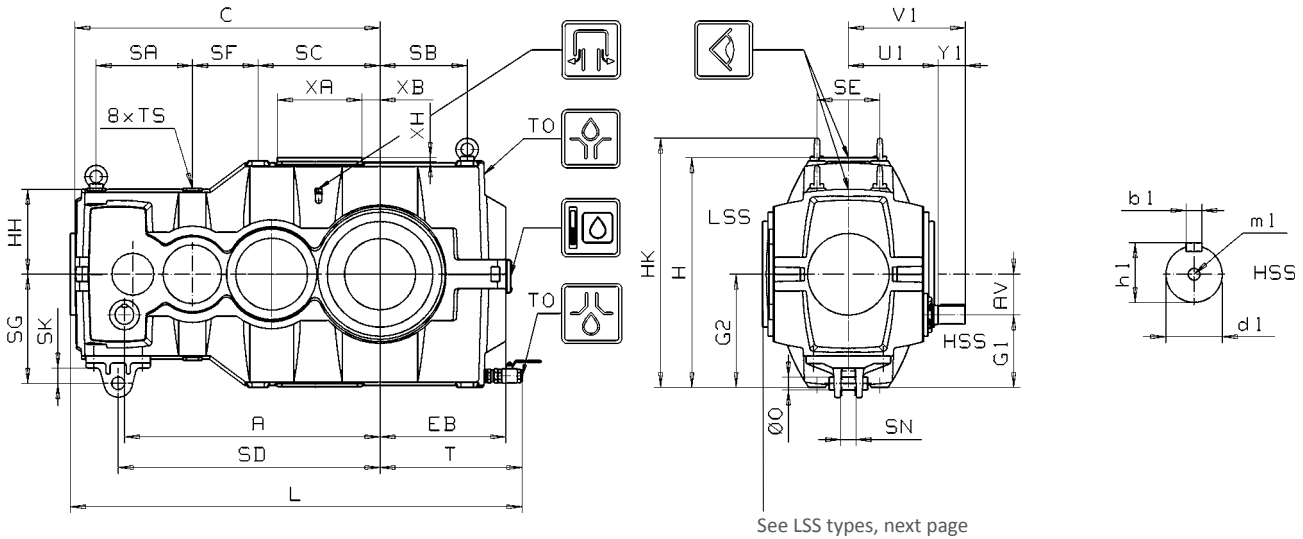

Size	Housing dimensions in mm																				
	A	AV	C	EB	G1	G2	H	HH	HK	L	SA	SB	SC	SE	SF	T	TO	TS	XA	XB	XH
100	1186	176.6	1386	560	333.4	510	1020	375	1129	2016	435	391	570	265	281	630	1 1/2"	M30	403	58	32
110	1293	193.9	1510	620	366.1	560	1120	410	1248	2200	480	440	640	290	290	690	1 1/2"	M36	403	86	32
120	1446	202.8	1700	680	387.2	590	1180	465	1308	2445	535	485	695	320	355	745	1 1/2"	M36	403	129	32
130	1545	224.3	1815	730	425.7	650	1300	489	1447	2610	580	530	760	360	360	795	1 1/2"	M42	403	129	32
140	1693	230.2	1973	780	479.8	710	1420	520	1567	2818	630	580	810	420	410	845	1 1/2"	M42	403	129	32
150	1767	264.3	2052	750	485.7	750	1505	755	1537	2977	0	0	0	0	0	925	1 1/2"	0	403	608	32
160	1910	289.7	2230	800	510.3	800	1610	810	1642	3205	0	0	0	0	0	975	1 1/2"	0	403	665	32

Size	HSS dimensions in mm							Torque arm mounting bracket					Weight	Oil capacity	
	$i_n=100...400$							O	SD	SG	SK	SN		kg	Splash lubrication
	U1	Y1	V1	d1	b1	h1	m1						l		l
100	375	125	500	65m6	18h9	69	M20	63	1190	470	75	70	3630	210	130
110	400	125	525	75m6	20h9	79.5	M20	63	1310	500	75	70	4720	275	155
120	431	150	581	80m6	22h9	85	M20	63	1475	555	75	70	6240	355	195
130	463	150	613	85m6	22h9	90	M20	63	1550	586	75	70	7970	560	235
140	494	150	644	90m6	25h9	95	M24	80	1650	675	120	90	9280	700	250
150	518	150	668	95m6	25h9	100	M24	80	1767	650	120	90	11990	860	280
160	548	190	738	100m6	28h9	106	M24	80	1910	700	120	90	14050	1030	320

Shaft Positions

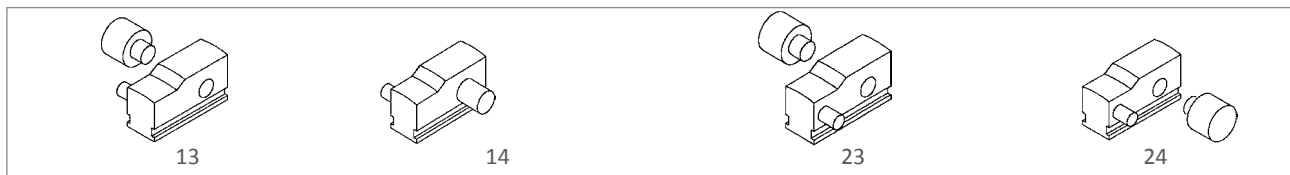

4-stage helical gear units, horizontal LSS

LSS types

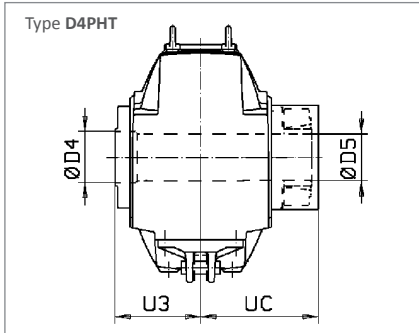

Hollow shaft, shrink disk, page 12.08

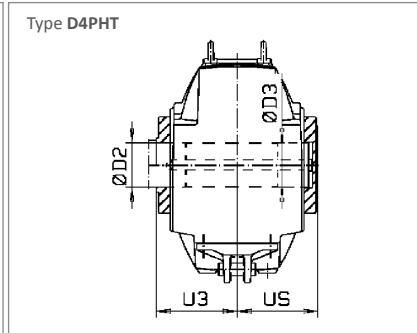

Hollow shaft, key connection, page 12.11

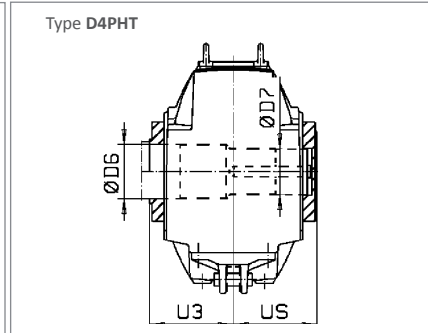

Hollow shaft, special key connection, page 12.12

Common accessories, see section 12

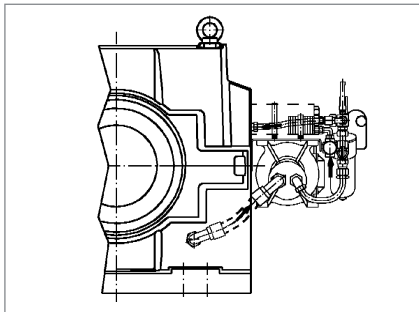

Lubrication unit, page 12.23

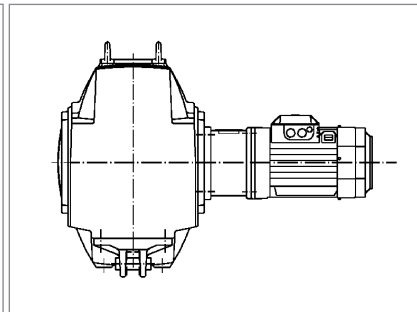

Motor flange, page 12.32

Size	LSS dimensions in mm								
	Hollow shaft								
	U3	UC	ØD4	ØD5	US	ØD2	ØD3	ØD6	ØD7
100	376	570	300	299	361	280	279	315	279
110	401	600	320	319	386	290	289	325	289
120	432	650	330	329	416	300	299	340	299
130	464	690	380	379	446	340	339	385	339
140	495	745	400	399	481	360	359	400	359
150	519	800	450	449	501	400	399	450	399
160	549	830	460	459	531	420	419	465	419

In case of through going LSS, same dimensions apply.

Other available accessories, see section 12

Lubrication and cooling	Page
Shaft end pump	12.24
Oil heating system	12.27
Optional seal arrangements	12.30
Labyrinth seal on HSS and LSS	2)

Coupled equipment	Page
Couplings	*)
Torque arm	12.31
Belt drive	12.32

2) Standard solution for this gear unit type
*) Contact Santasalo

See also modifications, page 12.35-12.37

5-stage helical gear units, horizontal LSS

Gear unit dimensions, type D5PSF D5PHF

Foot mounting face machined for foot mounting

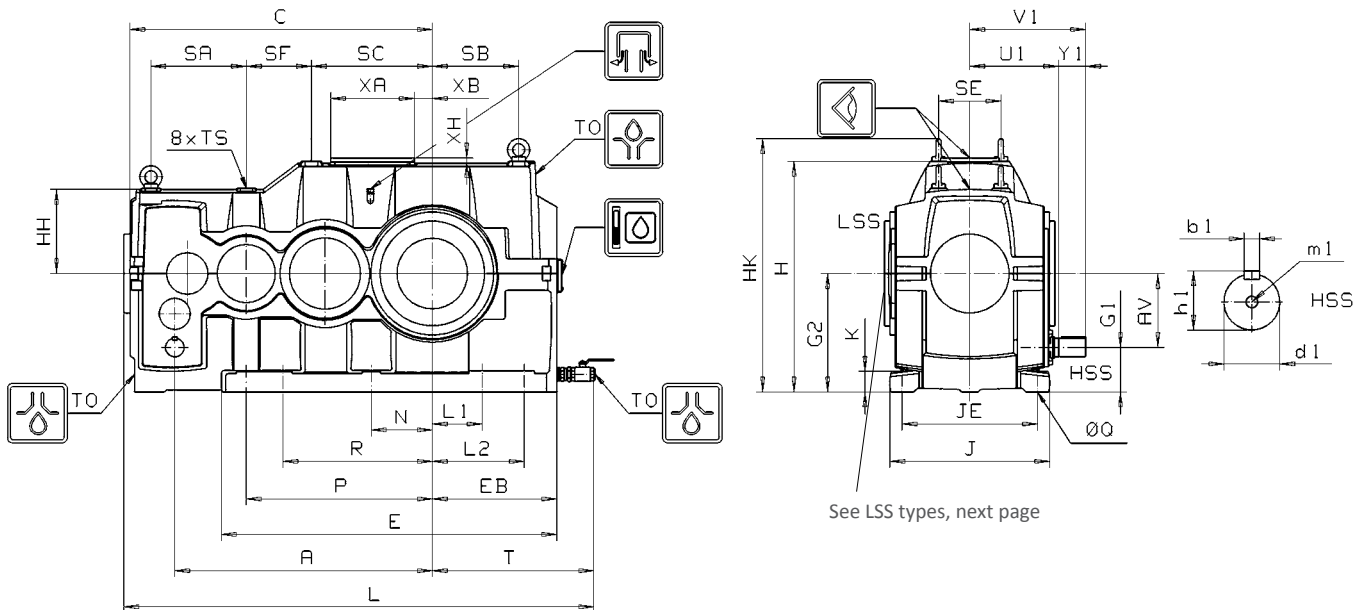

See LSS types, next page

Size	Housing dimensions in mm																							
	A	AV	C	E	EB	G1	G2	H	HH	HK	J	K	L	SA	SB	SC	SE	SF	T	TO	TS	XA	XB	XH
100	1186	328.6	1386	1496	560	211.4	540	1050	375	1159	690	100	2121	435	391	570	265	281	735	1 1/2"	M30	403	58	32
110	1293	355.9	1510	1658	620	214.1	570	1130	410	1258	750	100	2305	480	440	640	290	290	795	1 1/2"	M36	403	86	32
120	1446	378.8	1700	1836	680	231.2	610	1200	465	1328	810	103	2555	535	485	695	320	355	855	1 1/2"	M36	403	129	32
130	1545	224.3	1815	1984	730	263.7	680	1330	489	1477	860	103	2720	580	530	760	360	360	905	1 1/2"	M42	403	129	32
140	1693	433.2	1973	2115	780	296.8	730	1440	520	1587	914	110	2928	630	580	810	420	410	955	1 1/2"	M42	403	129	32
150	1767	482.3	2052	2357	750	287.7	770	1525	755	1557	942	95	2977	0	0	0	0	0	925	1 1/2"	0	403	608	32
160	1910	524.7	2230	2540	800	295.3	820	1630	810	1662	1002	95	3205	0	0	0	0	0	975	1 1/2"	0	403	665	32

Size	HSS dimensions in mm										Weight D5PSF/D5PHF kg	Oil capacity					
	$i_n=450...1800$							Foot mounting				Splash lubrication l	Pressure lubrication l				
	U1	Y1	V1	d1	b1	h1	m1	JE	L1	L2				N	P	Q	R
100	383	95	478	50k6	14h9	53.5	M16	580	300	420	300	850	48	730	4420/3880	290	130
110	408	95	503	55m6	16h9	59	M20	640	340	480	340	950	540	770	5490/4880	390	155
120	439	125	564	60m6	18h9	64	M20	690	340	540	340	1060	540	880	7170/6450	510	195
130	471	125	596	65m6	18h9	69	M20	740	390	590	390	1135	54	935	8900/8250	650	235
140	502	125	627	70m6	20h9	74.5	M20	794	440	660	394	1234	54	1035	10980/9850	830	290
150	526	125	651	75m6	20h9	79.5	M20	822	300	620	428	1476	54	1156	13420/12520	1010	320
160	556	150	706	80m6	22h9	85	M20	862	300	670	470	1610	54	1240	15640/14630	1220	380

Shaft Positions

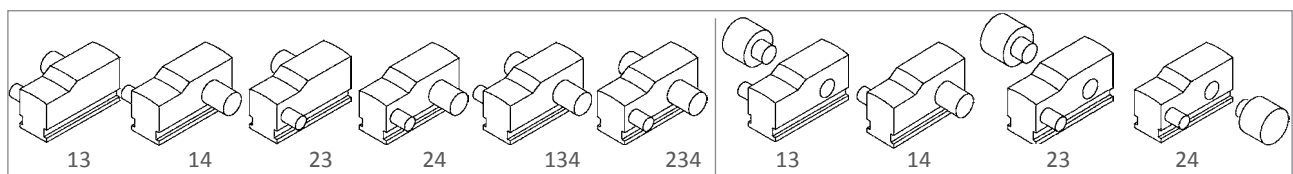

5-stage helical gear units, horizontal LSS

LSS types

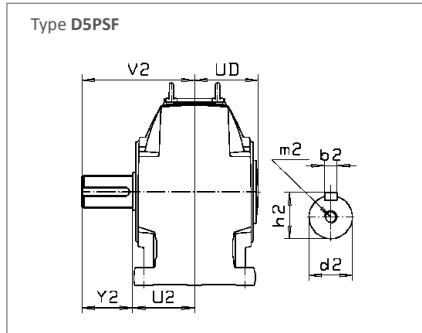

Solid shaft

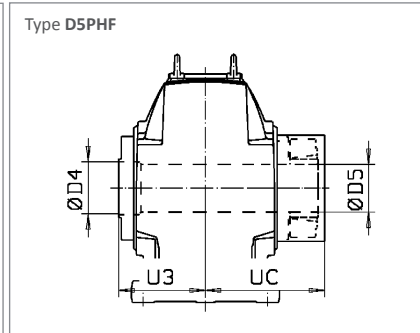

Hollow shaft, shrink disk, page 12.08

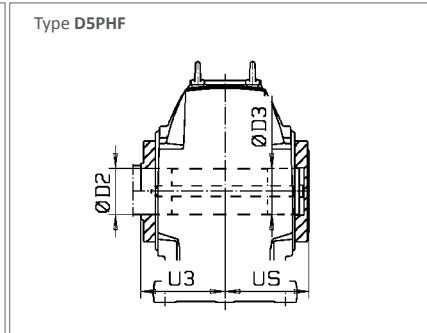

Hollow shaft, key connection, page 12.11

Common accessories, see section 12

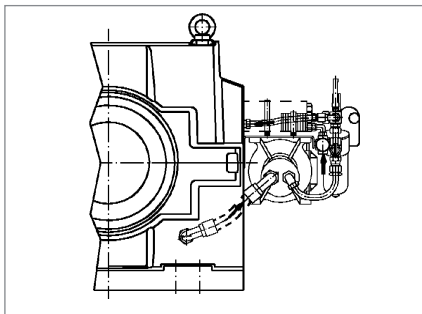

Lubrication unit, page 12.23

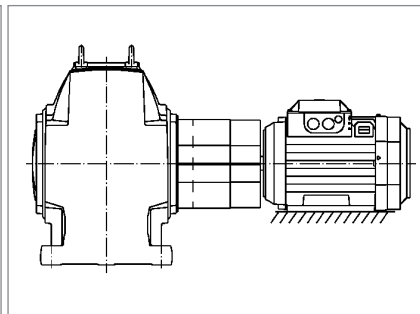

Coupling guard, page 12.31

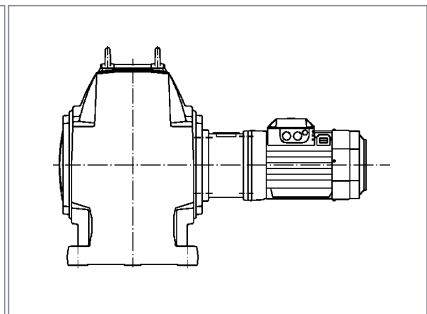

Motor flange, page 12.32

Size	LSS dimensions in mm																
	Solid shaft								Hollow shaft								
	d2	b2	h2	m2 (t)	Y2	U2	V2	UD	U3	UC	ØD4	ØD5	US	ØD2	ØD3	ØD4	ØD6
100	310m6	70h9	324	M24	380	391	771	361	376	570	300	299	361	280	279	315	279
110	330m6	70h9	344	M30	380	416	796	386	401	600	320	319	386	290	289	325	289
120	350m6	80h9	365	M30	450	447	897	416	432	650	330	329	416	300	299	340	299
130	370m6	80h9	385	M30	450	479	929	451	464	690	380	379	446	340	339	385	339
140	390m6	90h9	407	M30	540	510	1050	482	495	745	400	399	481	360	359	400	359
150	410m6	90h9	427	M30	540	534	1074	506	519	800	450	449	501	400	399	450	399
160	430m6	90h9	447	M30	540	564	1104	536	549	830	460	459	531	420	419	465	419

In case of through going LSS, same dimensions apply.

1) 2x180° distance 0.6 x d2

Other available accessories, see section 12

Lubrication and cooling	Page
Shaft end pump	12.24
Oil heating system	12.27

Optional seal arrangements	12.30
Labyrinth seal on HSS and LSS	2)

Coupled equipment	Page
Couplings	*)
Belt drive	12.32

See also modifications, page 12.35-12.37

2) Standard solution for this gear unit type
*) Contact Santasalo

2-stage bevel-helical gear units

Gear unit dimensions, type 2KC90M-225M

Foot mounting face machined for foot mounting

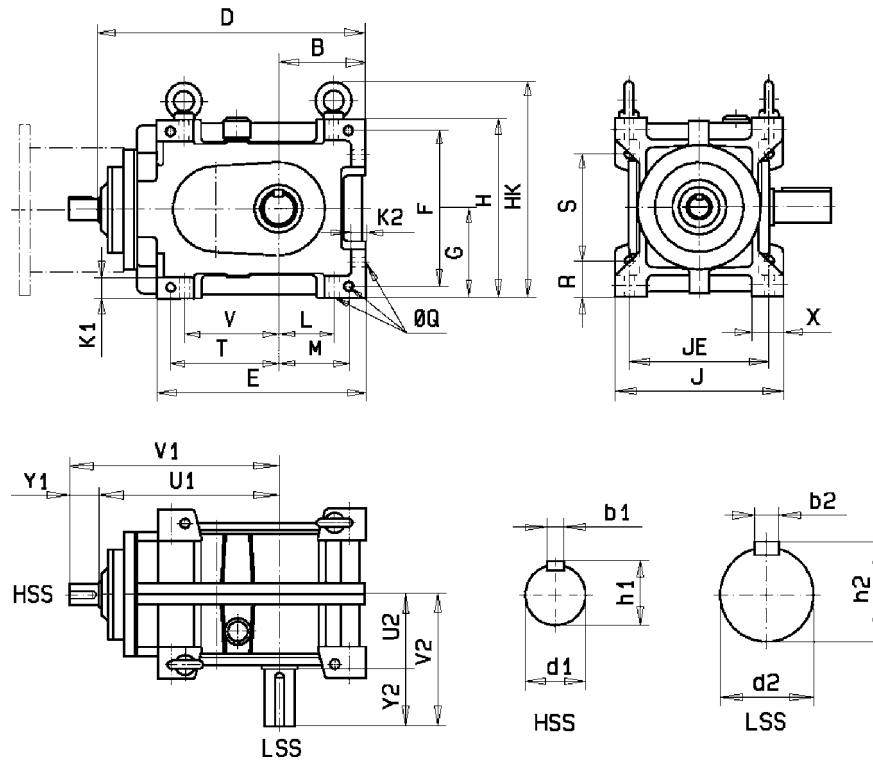

Size	Gear case dimensions in mm																		Weight	Quantity of oil	
	B	D	E	F	G	H	HK	J	JE	K1	K2	L	M	Q	R	S	T	V	X	kg	l
90M	125	385	303	220	125	250	303	240	200	30	20	80	100	14.5	50	150	155	135	50	65	2
110M	160	482	393	290	160	320	373	276	235	30	20	114	134	14.5	50	220	203	183	50	100	3.5
140M	180	585	489	365	200	400	462	340	294	35	25	127	150	18.5	58	284	280	255	60	150	6
180M	225	740	629	460	250	500	571	416	360	40	35	143	175	24	66	368	362	330	70	300	10
225M	280	930	804	580	315	630	720	560	480	55	45	185	235	28	95	440	460	410	100	580	18

Size	Shaft dimensions in mm																					
	Input shaft															Output shaft						
	$i_N=3.8...10.6$					$i_N=10.6...15$					$i_N=15..21$					U2	Y2	V2	d2	b2	h2	
	U1	Y1	V1	d1	b1	h1	Y1	V1	d1	b1	h1	Y1	V1	d1	b1	h1						
90M	260	42	302	28k6	8h9	31	36	296	20k6	6h9	22.5	25	285	14k6	5h9	16	100	82	182	45k6	14h9	48.5
110M	322	58	380	35k6	10h9	38	42	364	25k6	8h9	28	28	350	18k6	6h9	20.5	125	82	207	55m6	16h9	59
140M	405	82	487	45k6	14h9	48.5	58	463	35k6	10h9	38	36	441	22k6	6h9	24.5	150	105	255	65m6	18h9	69
180M	515	82	597	55m6	16h9	59	82	597	45k6	14h9	48.5	58	573	30k6	8h9	33	185	130	315	85m6	22h9	90
225M	650	105	755	65m6	18h9	69	82	732	55m6	16h9	59	82	732	40k6	12h9	43	225	165	390	110m6	28h9	116

Shaft positions

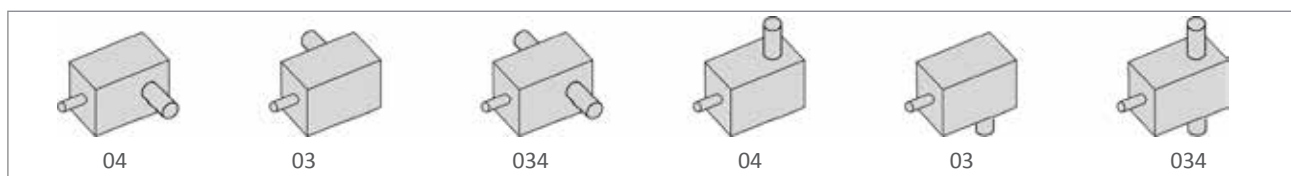

2-stage bevel-helical gear units

Gear unit dimensions, type 2KC250M-400M

Foot mounting face machined for foot mounting

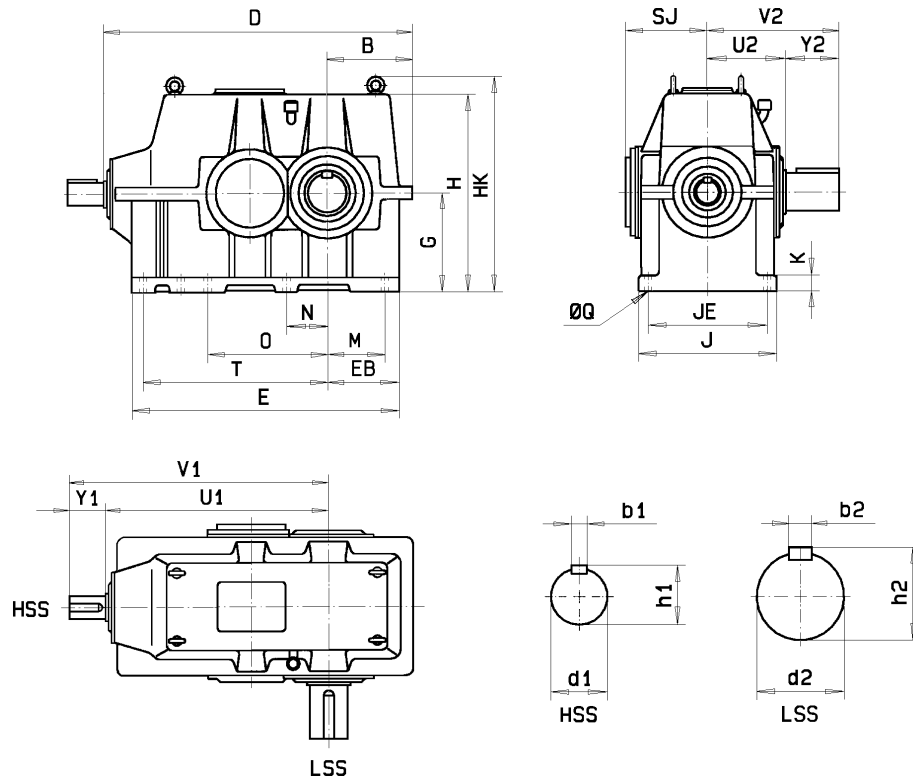

Size	Gear dimensions in mm																Weight kg	Quality of Oil	
	B	D	E	EB	G	H	HK	J	JE	K	M	N	O	SJ	T	Q		Splash lubrication l	Pressure lubrication l
250M	285	1010	874	237	315	630	701	460	390	50	185	130	-	277	580	28	680	56	27
280M	310	1120	975	262	355	710	780	500	430	56	215	150	465	314	660	28	930	78	47
315M	355	1260	1080	300	400	800	890	580	490	63	240	165	510	356	720	35	1340	110	56
355M	400	1420	1230	340	450	900	990	630	540	70	280	190	590	395	830	35	1810	160	80
400M	450	1600	1400	380	500	1000	1090	720	620	80	300	210	640	455	930	42	2420	220	110

Size	Shaft dimensions in mm																							
	Input shaft															Output shaft								
	$i_N=3.8...10.6$					$i_N=10.6...15$					$i_N=15...21$					U2	Y2	V2	d2	b2	h2			
	U1	Y1	V1	d1	b1	h1	Y1	V1	d1	b1	h1	Y1	V1	d1	b1	h1	U2	Y2	V2	d2	b2	h2		
250M	725	105	830	70m6	20h9	74.5	105	830	60m6	18h9	64	82	807	45k6	14h9	48.5	245	165	410	120m6	32h9	127		
280M	810	130	940	80m6	22h9	85	105	915	65m6	18h9	69	82	892	50k6	14h9	53.5	280	200	480	140m6	36h9	148		
	$i_N=4...7.1$					$i_N=7.6...12$					$i_N=12...21$													
315M	905	165	1070	100m6	28h9	106	130	1035	80m6	22h9	85	105	1010	65m6	18h9	69	315	200	515	150m6	36h9	158		
355M	1020	165	1185	110m6	28h9	116	130	1150	90m6	25h9	95	105	1125	70m6	20h9	74.5	350	240	590	170m6	40h9	179		
400M	1150	165	1315	120m6	32h9	127	165	1315	100m6	28h9	106	105	1255	75m6	20h9	79.5	390	280	670	190m6	45h9	200		

Shaft positions

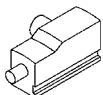

03

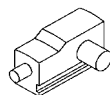

04

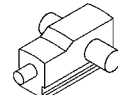

034

2-stage bevel-helical gear units

Gear unit dimensions, type 2TKC90M-225M

Foot mounting face machined for foot mounting

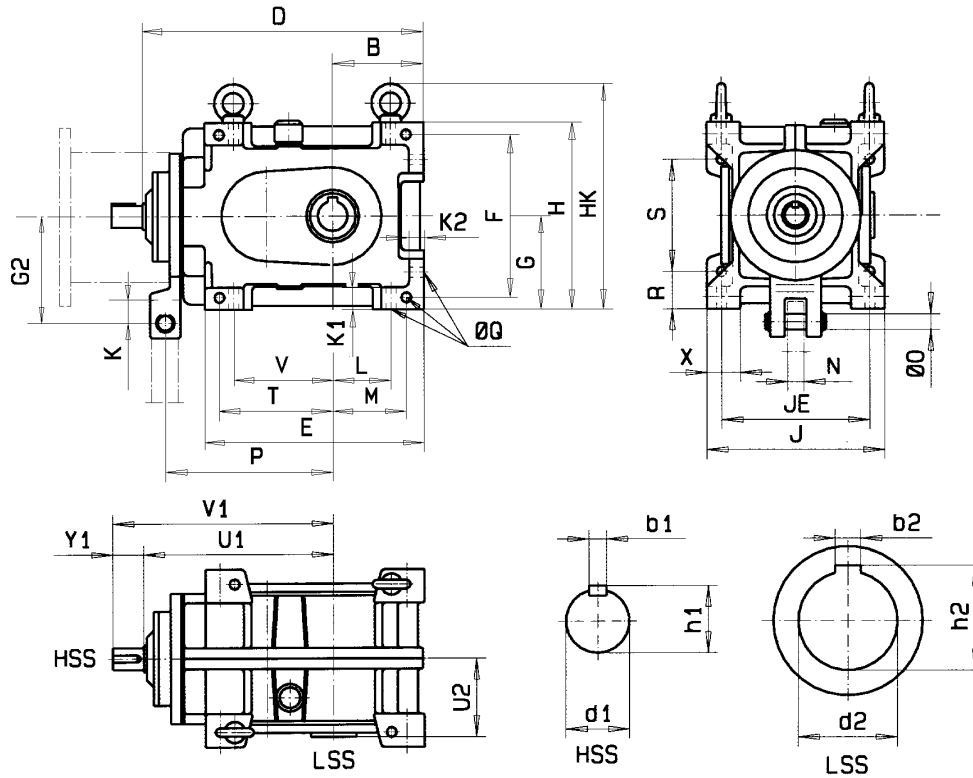

Size	Gear case dimensions in mm																				Weight kg	Quantity of Oil l				
	B	D	E	F	G	G2	H	HK	J	JE	K	K1	K2	L	M	N	O	P	Q	R			S	T	V	X
90M	125	385	303	220	125	140	250	303	240	200	28	30	20	80	100	20	22h9	233	14.5	50	150	155	135	50	65	2
110M	160	482	393	290	160	160	320	373	276	235	28	30	20	114	134	20	22h9	291	14.5	50	220	203	183	50	100	3.5
140M	180	585	489	365	200	210	400	462	340	294	28	35	25	127	150	20	22h9	369	18.5	58	284	280	255	60	150	6
180M	225	740	629	460	250	238	500	571	416	360	28	40	35	143	175	20	22h9	476	24	66	368	362	330	70	300	10
225M	280	930	804	580	315	286	630	720	560	480	38	55	45	185	235	32	32h9	606	28	95	440	460	410	100	580	18

Size	Shaft dimensions in mm																			
	Input shaft															Output shaft				
	$i_n=3.8...10.6$						$i_n=10.6...15$					$i_n=15...21$								
	U1	Y1	V1	d1	b1	h1	Y1	V1	d1	b1	h1	Y1	V1	d1	b1	h1	U2	d2	b2	h2
90M	260	42	302	28k6	8h9	31	36	296	20k6	6h9	22.5	25	285	14k6	5h9	16	100	45 H8	14 JS8	48.8
110M	322	58	380	35k6	10h9	38	42	364	25k6	8h9	28	28	350	18k6	6h9	20.5	122	60 H8	18 JS8	64.4
140M	405	82	487	45k6	14h9	48.5	58	463	35k6	10h9	38	36	441	22k6	6h9	24.5	132	70 H8	20 JS8	74.9
180M	515	82	597	55m6	16h9	59	82	597	45k6	14h9	48.5	58	573	30k6	8h9	33	160	90 H8	25 JS8	95.4
225M	650	105	755	65m6	18h9	69	82	732	55m6	16h9	59	82	732	40k6	12h9	43	204	110 H8	28 JS8	116.4

Shaft positions

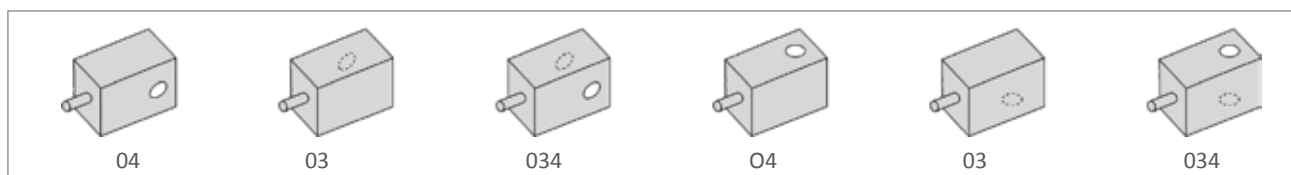

2-stage bevel-helical gear units

Gear unit dimensions, type 2TKC250M-400M

Foot mounting face machined for foot mounting

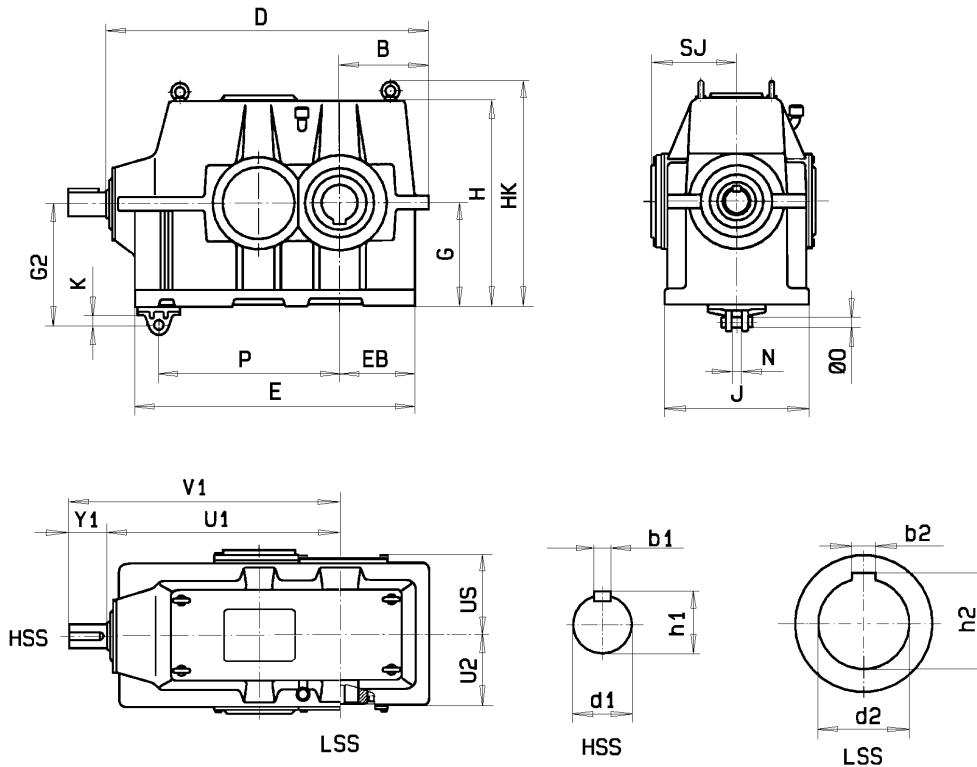

Size	Gear dimensions in mm														Weight kg	Quality of oil		
	B	D	E	EB	G	G2	H	HK	J	K	N	O	P	SJ		US	Splash lubrication l	Pressure lubrication l
250N	285	1010	874	237	315	381	630	701	460	38	32	32h9	550	277	240	680	56	27
280N	310	1120	975	262	355	423	665	736	500	38	32	32h9	565	304.5	272	930	78	47
315N	355	1260	1080	300	400	482	800	890	580	52	45	45h9	680	356	306	1340	110	56
355N	400	1420	1230	340	450	537	900	990	630	52	45	45h9	770	395	333	1810	160	80
400N	450	1600	1400	380	500	592	1000	1090	720	52	45	45h9	895	455	377	2420	220	110

Size	Shaft dimensions in mm																			
	Input shaft															Output shaft				
	$i_N=3.8...10.6$					$i_N=10.6...15$					$i_N=15...21$					U2	d2	b2	h2	
	U1	Y1	V1	d1	b1	h1	Y1	V1	d1	b1	h1	Y1	V1	d1	b1	h1				
250M	725	105	830	70m6	20h9	74.5	105	830	60m6	18h9	64	82	807	45k6	14h9	48.5	225	120 H8	32 JS9	127.4
280M	810	130	940	80m6	22h9	85	105	915	65m6	18h9	69	82	892	50k6	14h9	53.5	258	140 H8	36 JS9	148.4
	$i_N=3.6...10.6$					$i_N=10.6...12$					$i_N=12...21$									
315M	905	165	1070	100m6	28h9	106	130	1035	80m6	22h9	85	105	1010	65m6	18h9	69	291	160 H8	40 JS9	169.4
355M	1020	165	1185	110m6	28h9	116	130	1150	90m6	25h9	95	105	1125	70m6	20h9	74.5	317	180 H8	45 JS9	190.4
400M	1150	165	1315	120m6	32h9	127	165	1315	100m6	28h9	106	105	1255	75m6	20h9	79.5	361	200 H8	45 JS9	210.4

Shaft positions

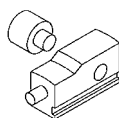

03

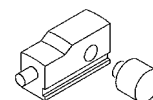

04

3-stage bevel-helical gear units

Gear unit dimensions, type 3KC140N-250N

Foot mounting face machined for foot mounting

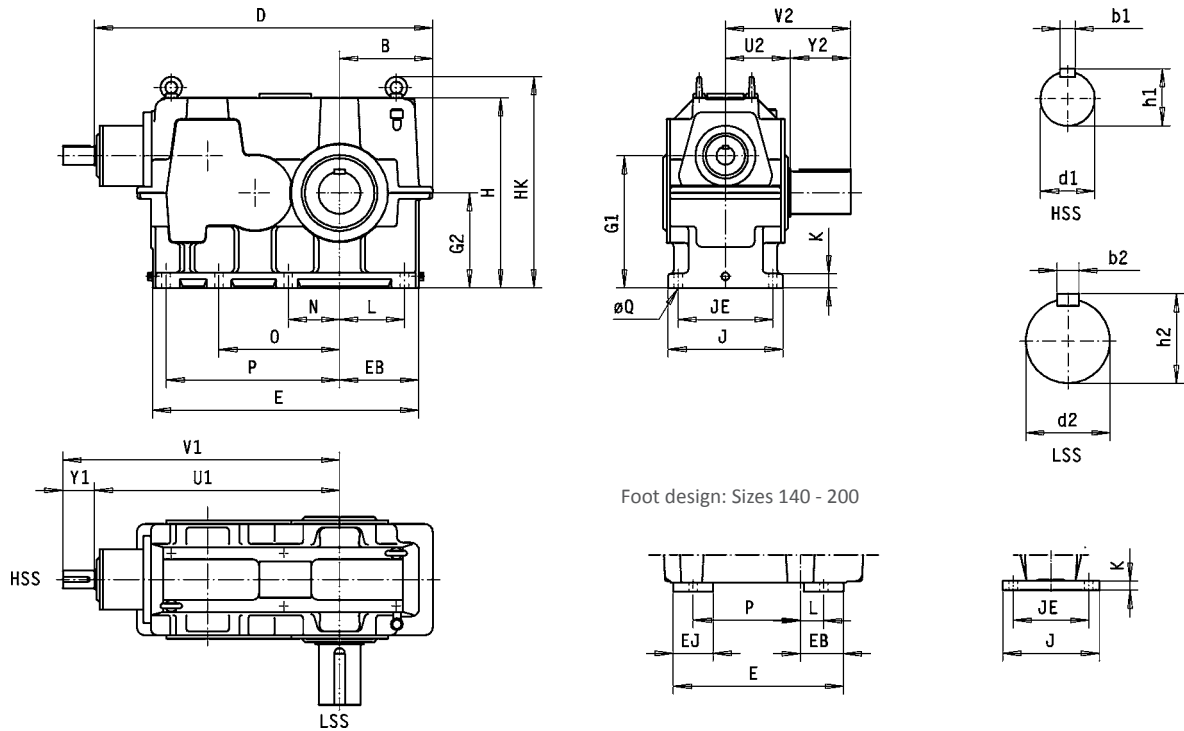

Size	Gear dimensions in mm																	Weight	Quantity of oil
	B	D	E	EB	EJ	G1	G2	H	HK	J	JE	K	L	N	O	P	Q	kg	l
140N	160	561.4	409	104	114	270.1	200	380	433	220	182	20	46	-	-	248	19	105	7.6
160N	175	625.5	468	113	125	302.1	225	425	478	260	210	25	50	-	-	292	24	145	10
180N	205	711.1	521	131	140	336.7	250	475	537	280	225	25	60	-	-	320	24	200	14
200N	225	800.0	582	152	150	366.6	280	530	592	320	250	30	77	-	-	355	28	280	20
225N	255	907.5	692	200	-	376.7	280	560	631	325	265	40	165	135	-	455	28	380	35
250N	281	1007.9	771	225	-	390.7	280	560	631	355	286	45	192	145	-	510	28	510	46

Size	Shaft dimensions in mm																					
	Input shaft															Output shaft						
	$i_N=19...47$					$i_N=47...67$					$i_N=67...95$					U2	Y2	V2	d2	b2	h2	
U1	Y1	V1	d1	b1	h1	Y1	V1	d1	b1	h1	Y1	V1	d1	b1	h1	U2	Y2	V2	d2	b2	h2	
140N	401.4	58	459.4	30k6	8h9	33	36	437.4	22k6	6h9	24.5	28	429.4	16k6	5h9	18	120	105	225	65m6	18h9	69
160N	450.5	58	508.5	35k6	10h9	38	42	492.5	25k6	8h9	28	28	478.5	18k6	6h9	20.5	140	105	245	75m6	20h9	79.5
180N	506.1	82	588.1	40k6	12h9	43	58	564.1	30k6	8h9	33	36	542.1	20k6	6h9	22.5	145	130	275	85m6	22h9	90
200N	575.0	82	657.0	45k6	14h9	48.5	58	633.0	35k6	10h9	38	36	611.0	22k6	6h9	24.5	155	130	285	95m6	25h9	100
225N	652.5	82	734.5	50k6	14h9	53.5	82	734.5	40k6	12h9	43	42	694.5	25k6	8h9	28	175	165	340	110m6	28h9	116
250N	726.9	82	808.9	55m6	16h9	59	82	808.9	45k6	14h9	48.5	58	784.9	30k6	8h9	33	195	165	360	120m6	32h9	127

Shaft positions

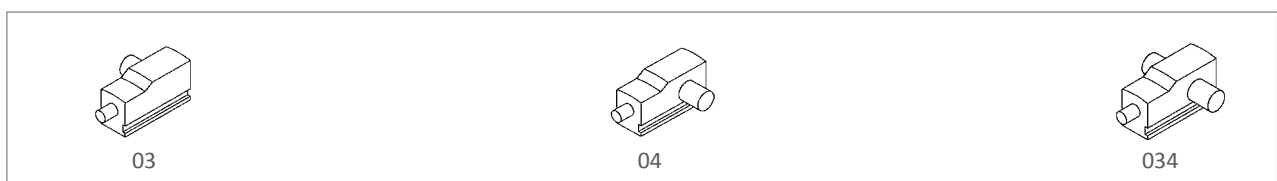

3-stage bevel-helical gear units

Gear unit dimensions, type 3TKC140N-250N

Torque arm mounting bracket with unmachined foot plane

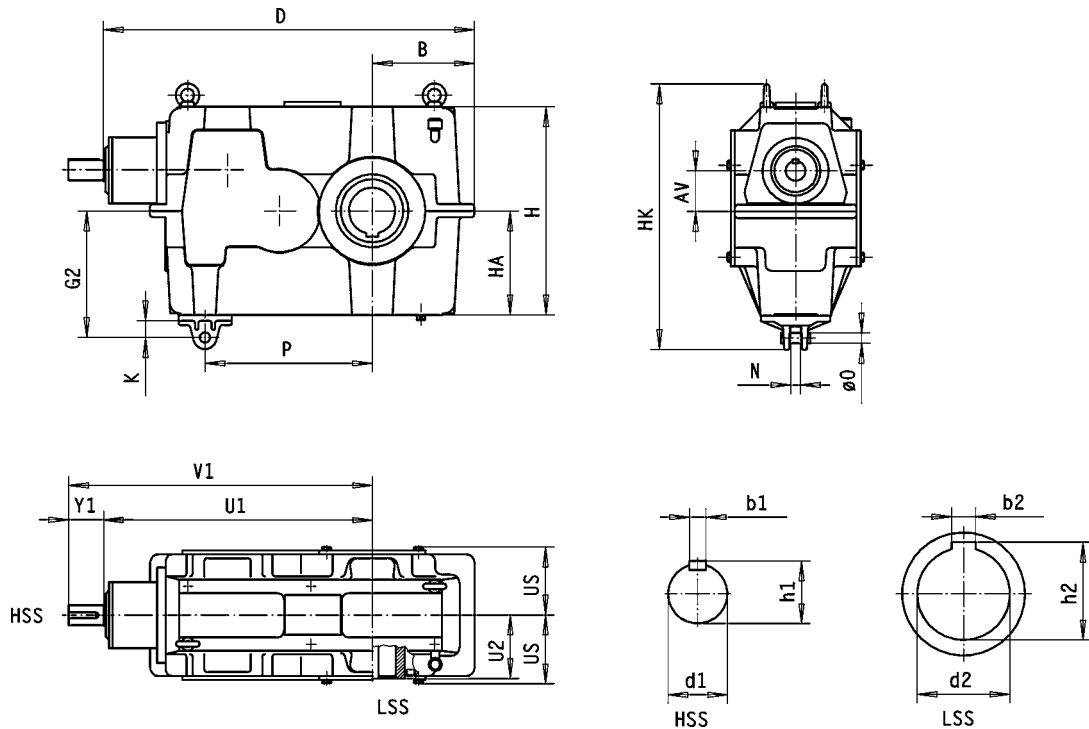

The dimensions of the hollow shaft hole: Page 12.01

Size	Gear dimensions in mm												Weight	Quantity of oil
	AV	B	D	G2	H	HA	HK	K	N	O	P	US	kg	l
140N	70.1	160	561.4	223	360	180	481	28	20	22h9	250	114	105	7.6
160N	77.1	175	625.5	243	400	200	521	28	20	22h9	285	131	145	10
180N	86.7	205	711.1	273	450	225	585	28	20	22h9	320	139	200	14
200N	86.6	225	800.0	298	500	250	635	28	20	22h9	360	149	280	20
225N	96.7	255	907.5	343	560	280	729	38	32	32h9	405	167	380	27
250N	110.7	281	1007.9	346	560	280	729	38	32	32h9	450	187	510	30

Size	Shaft dimensions in mm																					
	Input shaft															Output shaft						
	$i_n=19...47$					$i_n=47...67$					$i_n=67...95$					U2	Y2	V2	d2	b2	h2	
U1	Y1	V1	d1	b1	h1	Y1	V1	d1	b1	h1	Y1	V1	d1	b1	h1	U2	Y2	V2	d2	b2	h2	
140N	401.4	58	459.4	30k6	8h9	33	36	437.4	22k6	6h9	24.5	28	429.4	16k6	5h9	18	120	105	225	65m6	18h9	69
160N	450.5	58	508.5	35k6	10h9	38	42	492.5	25k6	8h9	28	28	478.5	18k6	6h9	20.5	140	105	245	75m6	20h9	79.5
180N	506.1	82	588.1	40k6	12h9	43	58	564.1	30k6	8h9	33	36	542.1	20k6	6h9	22.5	145	130	275	85m6	22h9	90
200N	575.0	82	657.0	45k6	14h9	48.5	58	633.0	35k6	10h9	38	36	611.0	22k6	6h9	24.5	155	130	285	95m6	25h9	100
225N	652.5	82	734.5	50k6	14h9	53.5	82	734.5	40k6	12h9	43	42	694.5	25k6	8h9	28	175	165	340	110m6	28h9	116
250N	726.9	82	808.9	55m6	16h9	59	82	808.9	45k6	14h9	48.5	58	784.9	30k6	8h9	33	195	165	360	120m6	32h9	127

Shaft positions

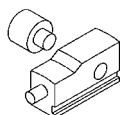

03

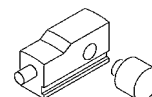

04

3-stage bevel-helical gear units

Gear unit dimensions, type 3TKCV140N-400N

Torque arm mounting bracket with unmachined foot plane

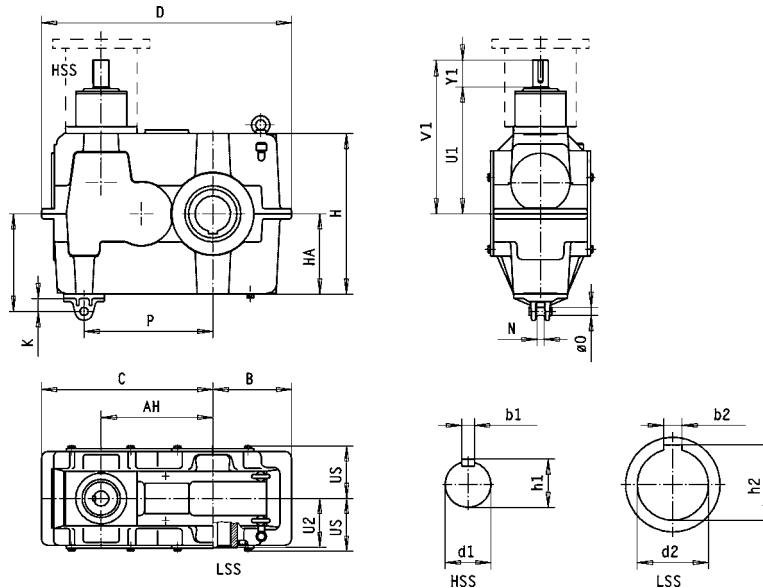

The dimensions of the hollow shaft hole: Page 12.01

Size	Gear case dimensions in mm												Weight kg	Quantity of oil l
	AH	B	C	D	G2	H	HA	K	N	O	P	US		
140N	211.4	160	355	515	223	360	180	28	20	22h9	250	114	105	7.6
160N	238.5	175	404	579	243	400	200	28	20	22h9	285	131	145	10
180N	270.1	205	450	655	273	450	225	28	20	22h9	320	139	200	14
200N	310.0	225	500	725	298	500	250	28	20	22h9	360	149	280	20
225N	352.5	255	555	810	343	560	280	38	32	32h9	405	167	380	27
250N	391.9	281	606	887	346	560	280	38	32	32h9	450	187	510	30
280N	437.8	308	671	979	383	630	315	38	32	32h9	505	206	720	42
315N	490.1	353	758	1111	437	710	355	52	45	45h9	565	233	1000	57
355N	548.8	400	863	1263	487	800	400	52	45	45h9	635	256	1350	77
400N	618.5	448	946	1394	542	900	450	52	45	45h9	715	286	1900	104

Size	Shaft dimensions in mm																			
	Input shaft															Output shaft				
	$i_N=18...45$					$i_N=50...63$					$i_N=71...90$					U2	d2	b2	h2	
U1	Y1	V1	d1	b1	h1	Y1	V1	d1	b1	h1	Y1	V1	d1	b1	h1	U2	d2	b2	h2	
140N	260.1	58	318.1	30k6	8h9	33	36	296.1	22k6	6h9	24.5	28	288.1	16k6	5h9	18	100	70H8	20JS9	74.9
160N	289.1	58	347.1	35k6	10h9	38	42	331.1	25k6	8h9	28	28	317.1	18k6	6h9	20.5	118	80H8	22JS9	85.4
180N	322.7	82	404.7	40k6	12h9	43	58	380.7	30k6	8h9	33	36	358.7	20k6	6h9	22.5	125	90H8	25JS9	95.4
200N	351.6	82	433.6	45k6	14h9	48.5	58	409.6	35k6	10h9	38	36	387.6	22k6	6h9	24.5	135	100H8	28JS9	106.4
225N	396.7	82	478.7	50k6	14h9	53.5	82	478.7	40k6	12h9	43	42	438.7	25k6	8h9	28	154	110H8	28JS9	116.4
250N	445.7	82	527.7	55m6	16h9	59	82	527.7	45k6	14h9	48.5	58	503.7	30k6	8h9	33	172	120H8	32JS9	127.4
280N	497.8	105	602.8	60m6	18h9	64	82	579.8	50k6	14h9	53.5	58	555.8	35k6	10h9	38	192	140H8	36JS9	148.4
315N	566.4	105	67.1	65m6	18h9	69	82	648.4	55m6	16h9	59	82	648.4	40k6	12h9	43	218	160H8	40JS9	169.4
355N	633.0	105	738.0	70m6	20h9	74.5	105	738.0	60m6	18h9	64	82	715.0	45k6	14h9	48.5	240	180H8	45JS9	190.4
400N	705.2	130	835.2	80m6	22h9	85	105	810.2	65m6	18h9	69	82	787.2	50k6	14h9	53.5	270	200H8	45JS9	210.4

Shaft positions

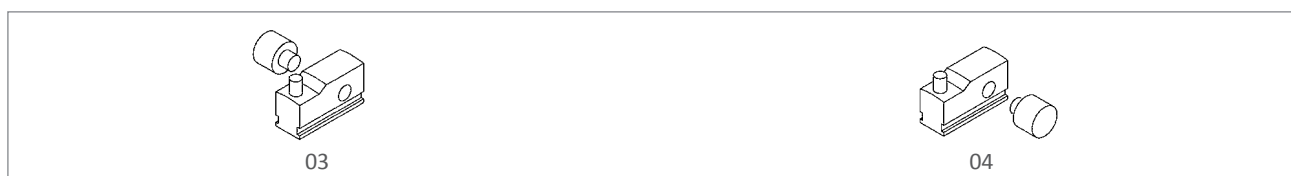

Gear unit dimensions, type D3RSF D3RHF D3RHT

Foot mounting face machined for foot mounting, type D3RSF D3RHF

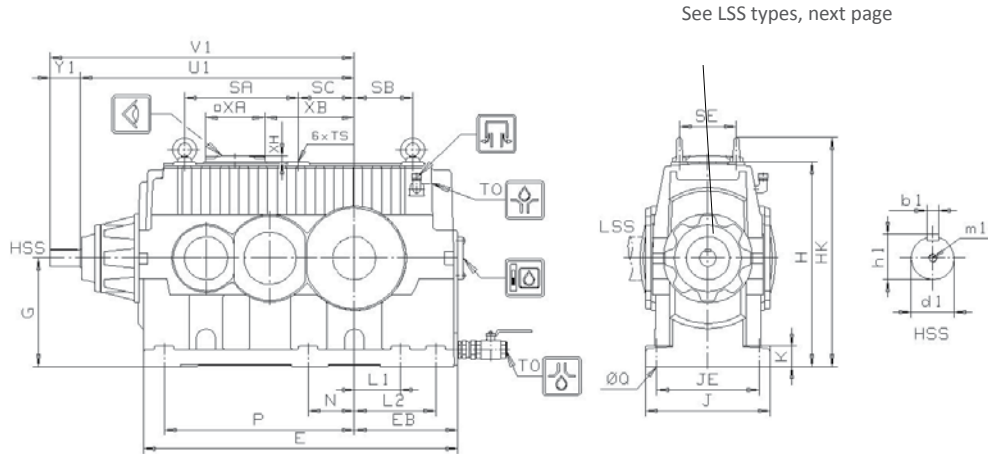

See LSS types, next page

Torque arm mounting bracket with unmachined foot plane, type D3RHT

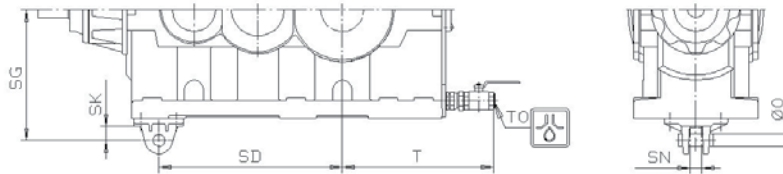

Size	Housing dimensions in mm																	Foot mounting					
																		Type D3RSF D3RHF					
	E	EB	G	H	HK	J	K	SA	SB	SC	SE	TS	TO	T	XA	XB	XH	JE	L1	L2	N	P	Q
50	994	325	350	660	731	396	65	376	190	175	188	M20x35	1½	500	220	253	30	330	148	245	148	600	28
60	1149	373	400	755	845	460	76	420	215	205	216	M24x42	1½	548	220	305	30	378	170	300	170	700	35
70	1320	427	460	870	960	506	82	460	276	270	250	M24x42	1½	602	260	370	30	416	194	322	194	800	35
80	1418	470	505	955	1045	552	90	490	300	280	250	M24x42	1½	645	260	390	30	454	209	369	209	853	42
90	1551	512	550	1040	1149	584	97	588	346	291	280	M30x53	1½	687	260	455	30	480	228	418	228	945	42
95	1573	500	500	980	1090	640	75	0	360	995	265	M30x53	1½	862	403	438.5	32	535	0	410	335	655	42

Size	HSS dimensions in mm													Torque arm mounting bracket Type D3RHT					Weight kg	Oil capacity				
	i _N =14...56						i _N =63...80							O	SD	SG	SK	SN		Splash lubrication	Pressure lubrication			
	U1	Y1	V1	d1	b1	h1	m1	Y1	V1	d1	b1	h1	m1							l	l			
50	881	95	976	55m6	16h9	59	M20	95	976	45k6	14h9	48.5	M16	32	580	418	38	32	846	62	38			
60	1012	125	1137	65m6	18h9	69	M20	95	1107	55m6	16h9	59	M20	45	676	482	52	45	1273	92	41			
70	1142	125	1267	75m6	20h9	79.5	M20	125	1267	60m6	18h9	64	M20	45	795	542	52	45	1879	144	64			
	i _N =14...63						i _N =71...80																	
80	1192	125	1317	75m6	20h9	79.5	M20	125	1317	60m6	18h9	64	M20	45	845	587	52	45	2375	185	79			
90	1363	150	1513	90m6	25h9	95	M24	125	1488	70m6	20h9	74.5	M20	45	945	632	52	45	3150	227	105			
95	1473	165	1638	115m6	32h9	122	M24	165	1638	115m6	32h9	122	M24	-	-	-	-	-	3400	155	125			

Shaft positions

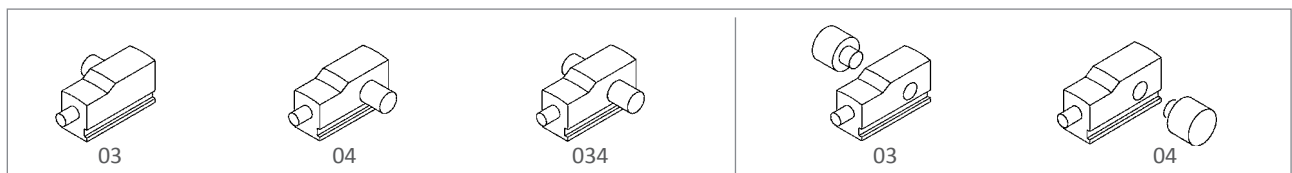

3-stage bevel-helical gear units, horizontal LSS

LSS types

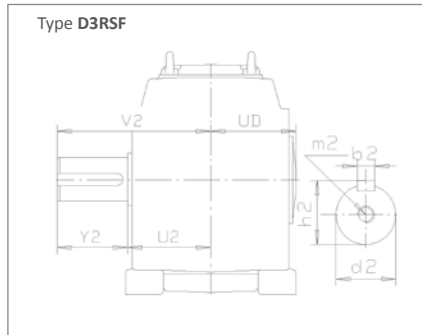

Solid shaft

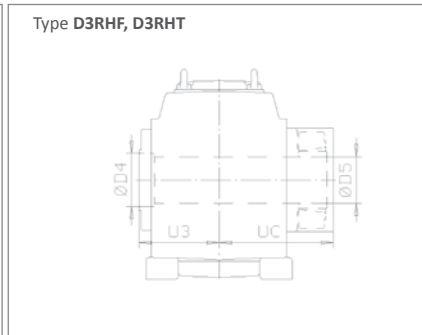

Hollow shaft, shrink disk, page 12.07

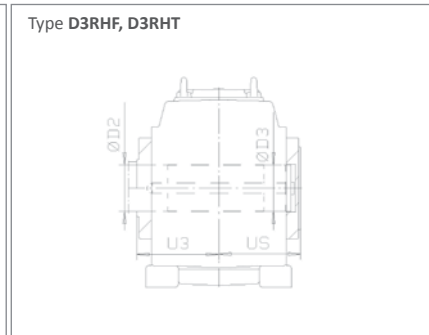

Hollow shaft, key connection, page 12.10

Common accessories, see section 12

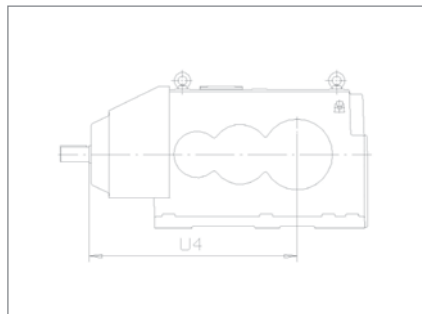

Fan, page 12.21

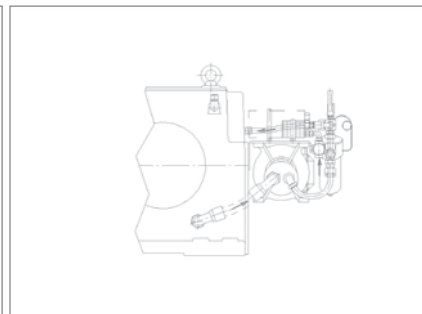

Lubrication unit, page 12.23

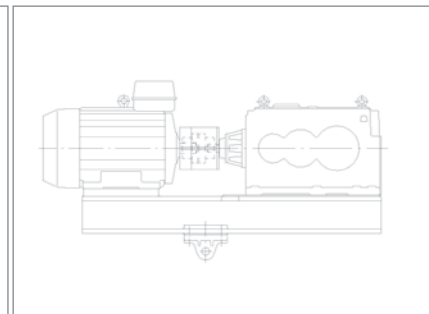

Swing base for motor, page 12.36

Size	LSS dimensions in mm															Common accessories
	Solid shaft						Hollow shaft									
	d2	b2	h2	m2	Y2	U2	V2	UD	U3	UC	D4	D5	US	D2	D3	
50	140m6	36h9	148	M30	200	232	432	216	228	336	155	154	232	150	149	998
60	160m6	40h9	169	M30	240	261	501	245	255	386	180	179	259	170	169	1129
70	180m6	45h9	190	M30	240	281	521	274	284	422	190	189	288	190	189	1278
80	200m6	45h9	210	+))	280	315	595	290	302	453	210	209	306	210	209	1328
90	220m6	50h9	231	+))	280	337	617	314	324	501	250	249	328	240	239	1499
95	270m6	63h9	287	++))	350	390	740	367	-	-	-	-	-	-	-	1602

In case of Through going LSS, same dimensions apply.

+) M20, 2x180° distance 0.6xd2

++) M24, 2x190° distance 0.6xd2

Other available accessories, see section 12

Lubrication and Cooling	Page
Cooling coil system	12.22
Shaft end pump	12.24
Central lubrication systems connections	12.25
Oil heating system	12.27
Optional seal arrangements	12.30
Lip seal on HSS and LSS	2)

Coupled equipment	Page
Couplings	*)
Coupling guard	12.31
Torque arm	12.31
Belt drive	12.32
Motor flange	12.32
Backstop	12.33

2) Standard Solution for this Gear Unit type
 *) Contact Santasalo

See also modifications, page 12.35-12.37

4-stage bevel-helical gear units, horizontal LSS

Gear unit dimensions, type D4RSF D4RHF D4RHT

Foot mounting face machined for foot mounting, type D4RSF D4RHF

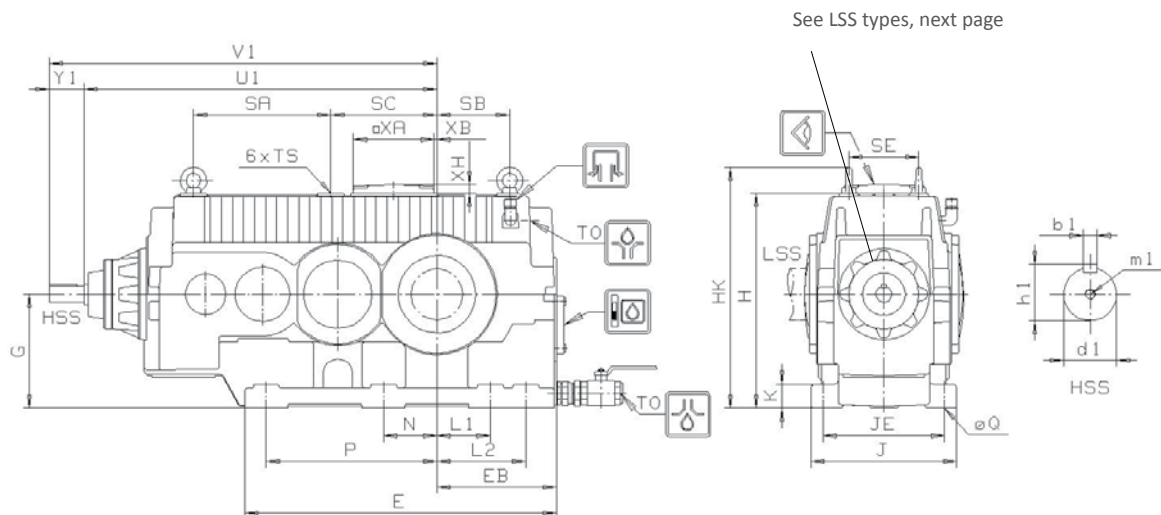

Torque arm mounting bracket with unmachined foot plane, type D4RHT

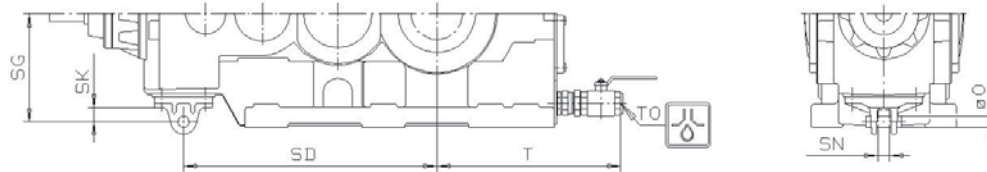

Size	Housing dimensions in mm																Foot mounting Type D4RSF D4RHF						
	E	EB	G	H	HK	J	K	SA	SB	SC	SE	TS	TO	T	XA	XB	XH	JE	L1	L2	N	P	Q
50	846	325	310	585	656	396	65	373	198	288	188	M20x35	1½	500	220	7	30	330	148	245	145	463	28
60	974	373	350	665	755	460	73	420	245	325	216	M24x42	1½	548	220	40	30	378	170	300	168	533	35
70	1135	427	400	760	850	506	82	475	292	418	250	M24x42	1½	602	260	92	30	416	194	322	190	633	35
80	1230	470	440	835	944	552	90	541	328	395	280	M30x53	1½	645	260	62	30	454	209	369	209	666	42
90	1324	512	480	910	1019	584	97	531	361	525	305	M30x53	1½	687	260	192	30	480	228	418	228	719	42

Size	HSS dimensions in mm													Torque arm mounting bracket Type D4RHT					Weight kg	Oil capacity	
	$i_n=90...250$						$i_n=280...315$							O	SD	SG	SK	SN		Splash lubrication	Pressure lubrication
	U1	Y1	V1	d1	b1	h1	m1	Y1	V1	d1	b1	h1	m1						l	l	
50	958	95	1053	45k6	14h9	48.5	M16	70	1028	35k6	10h9	38	M12	32	693	294	38	32	895	58	58
60	1045	95	1140	45k6	14h9	48.5	M16	70	1115	35k6	10h9	38	M12	45	775	308	52	45	1285	85	85
70	1235	95	1330	55m6	16h9	59	M20	95	1330	45k6	14h9	48.5	M16	45	928	380	52	45	1810	128	128
80	1285	95	1380	55m6	16h9	59	M20	95	1380	45k6	14h9	48.5	M16	45	978	380	52	45	2260	164	164
90	1438	125	1563	65m6	18h9	69	M20	95	1533	55m6	16h9	59	M20	45	1107	389	52	45	2980	213	213

Shaft positions

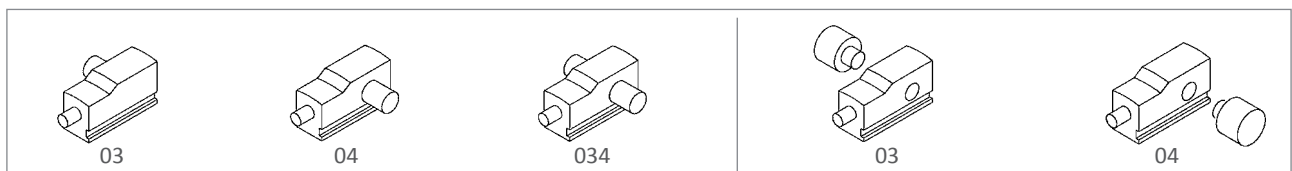

4-stage bevel-helical gear units, horizontal LSS

LSS types

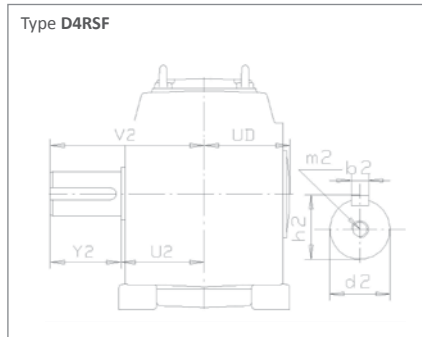

Solid shaft

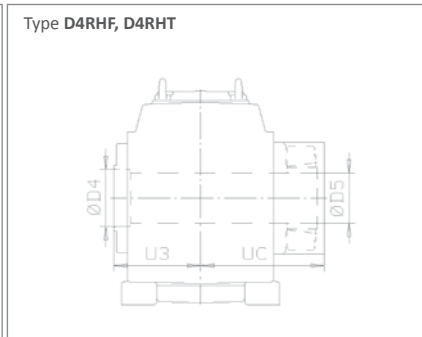

Hollow shaft, shrink disk, page 12.07

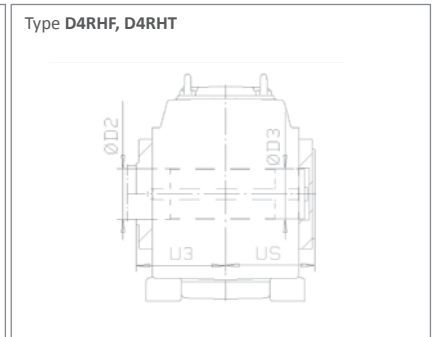

Hollow shaft, key connection, page 12.10

Common accessories, see section 12

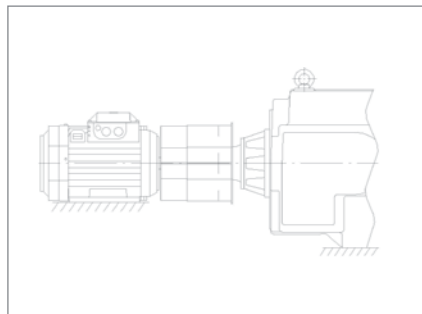

Coupling guard, page 12.31

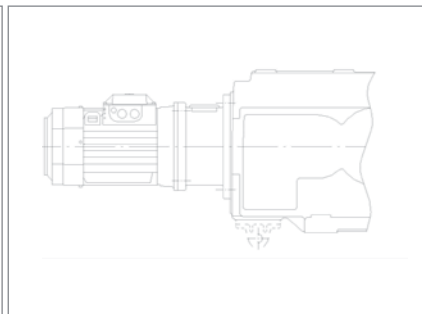

Motor flange, page 12.32

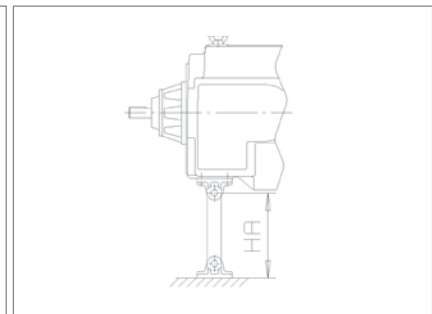

Torque arm, page 12.31

Size	LSS dimensions in mm														Common accessories		
	Solid shaft							Hollow shaft							H Amin	H Amax	
	d2	b2	h2	M30	Y2	U2	V2	UD	U3	UC	D4	D5	US	D2	D3		
50N	140m6	36h9	148	M30	200	232	432	216	228	336	155	154	232	150	149	125	950
60N	160m6	40h9	169	M30	240	261	501	245	255	386	180	179	259	170	169	175	1070
70N	180m6	45h9	190	M30	240	281	521	274	284	422	190	189	288	190	189	175	1070
80N	200m6	45h9	210	+)	280	315	595	290	302	453	210	209	306	210	209	175	1070
90N	220m6	50h9	231	+)	280	337	617	314	324	501	250	249	328	240	239	175	1070

In case of Through going LSS, same dimensions apply.

+) M20,2x180°, distance 0.6xd2

Other available accessories, see section 12

Lubrication and Cooling	Page
Lubrication unit	12.21
Shaft end pump	12.24
Central lubrication systems connections	12.25
Oil heating system	12.27

Coupled equipment	Page
Couplings	*)
Belt drive	12.32
Backstop	12.33

2) Standard Solution for this Gear Unit type
 *) Contact Santasalo

See also modifications, page 12.35-12.37

Optional seal arrangements	12.30
Lip seal on HSS and LSS	2)

4-stage bevel-helical gear units, horizontal LSS

Gear unit dimensions, type D4RSF D4RHF

Foot mounting face machined for foot mounting

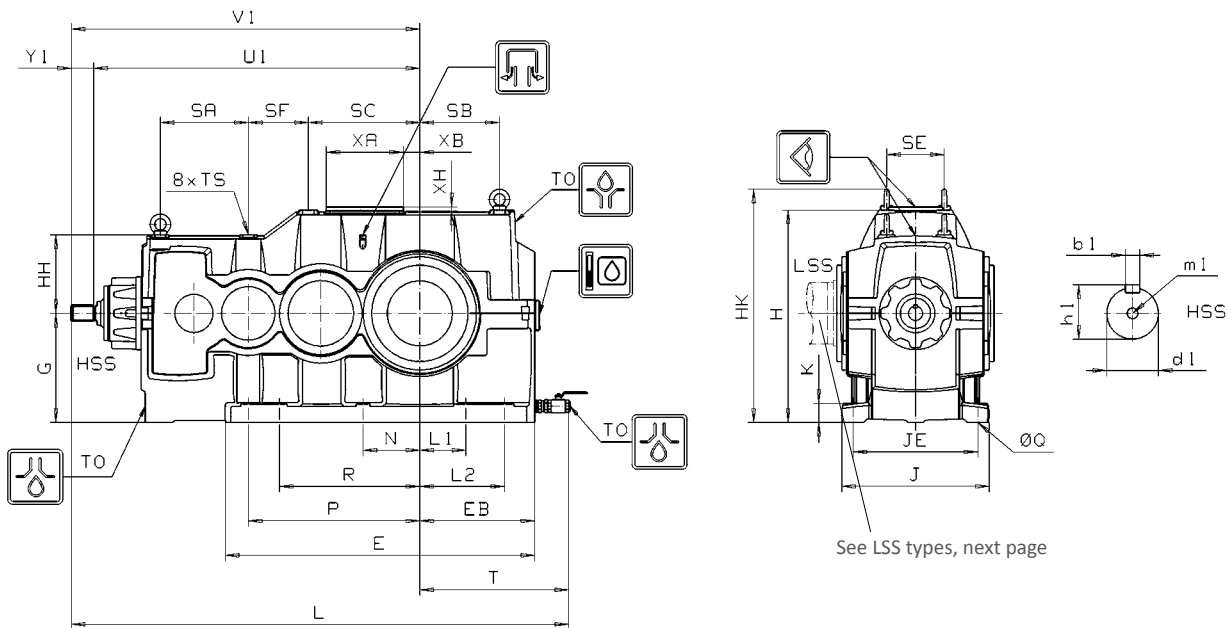

See LSS types, next page

Size	Housing dimensions in mm																	Foot mounting									
	E	EB	G	H	HH	HK	J	JX	K	SA	SB	SC	SE	SF	T	TO	TS	XA	XB	XH	JE	L1	L2	N	P	Q	R
100	1496	560	540	1050	375	1159	690	380	100	435	391	570	265	281	735	1 1/2"	M30	403	58	32	580	300	420	300	850	48	730
110	1658	620	570	1130	410	1258	750	418	100	480	440	640	290	290	795	1 1/2"	M36	403	86	32	640	340	480	340	950	54	770
120	1836	680	610	1200	465	1328	810	450	103	535	485	695	320	355	855	1 1/2"	M36	403	129	32	690	340	540	340	1060	54	880
130	1984	730	680	1330	489	1477	860	506	103	580	530	760	360	360	905	1 1/2"	M42	403	129	32	740	390	590	390	1135	54	935
140	2115	780	730	1440	520	1587	914	554	110	630	580	810	420	410	955	1 1/2"	M42	403	129	32	794	440	660	394	1234	54	1035
150	2357	750	770	1525	755	1557	942	-	95	0	0	0	0	0	925	1 1/2"	0	403	608	32	822	300	620	428	1476	54	1156
160	2540	800	820	1630	810	1662	1002	-	95	0	0	0	0	0	975	1 1/2"	0	403	665	32	862	300	670	470	1610	54	1240

Size	HSS dimensions in mm														Weight		Oil capacity	
	$i_N = 90...250$							$i_N = 280...315$							D4RSF/D4RHF	kg	Splash lubrication	Pressure lubrication
	U1	Y1	V1	d1	b1	h1	m1	L	Y1	V1	d1	b1	h1	m1				
100	1596	125	1721	65m6	18h9	69	M20	2456	95	1691	55m6	16h9	59	M20	2426	4410/3870	290	130
110	1733	125	1858	70m6	20h9	74.5	M20	2653	95	1828	55m6	16h9	59	M20	2623	5580/4970	390	155
120	1992	150	2142	85m6	22h9	90	M20	2997	125	2117	70m6	20h9	74.5	M20	2972	7400/6690	510	195
130	2115	150	2265	95m6	25h9	100	M24	3170	125	2240	75m6	20h9	79.5	M20	3145	9170/8570	650	235
140	2258	190	2448	100m6	28h9	106	M24	3403	125	2383	75m6	20h9	79.5	M20	3338	11340/10210	830	290
150	2457	190	2647	110m6	28h9	116	M24	3572	150	2607	80m6	22h9	85	M20	3532	13840/12940	1010	320
160	2640	190	2830	120m6	32h9	127	M24	3805	150	2790	90m6	25h9	95	M24	3765	16040/15040	1220	380

Shaft positions

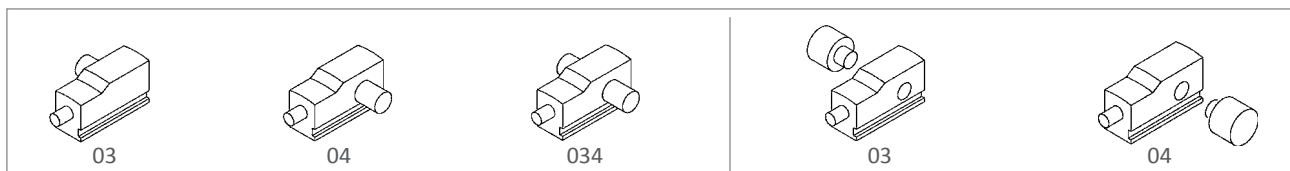

4-stage bevel-helical gear units, horizontal LSS

LSS types

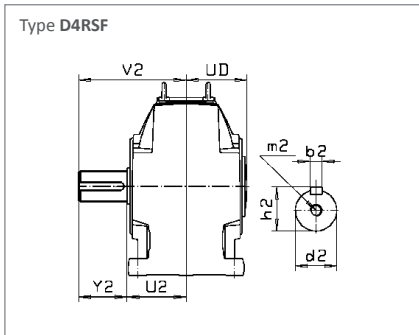

Solid shaft

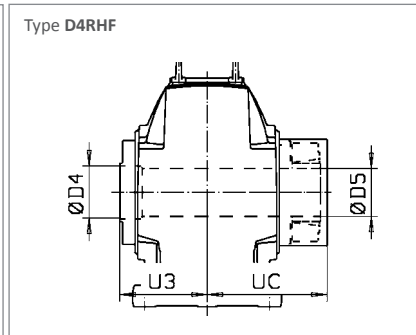

Hollow shaft, shrink disk, page 12.08

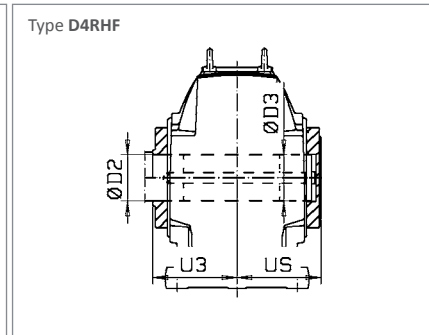

Hollow shaft, key connection, page 12.11

Common accessories, see section 12

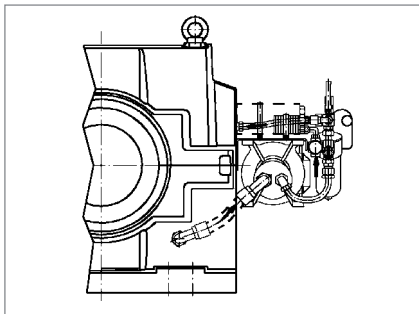

Lubrication unit, page 12.23

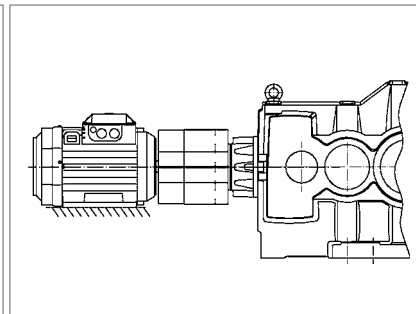

Coupling guard, page 12.31

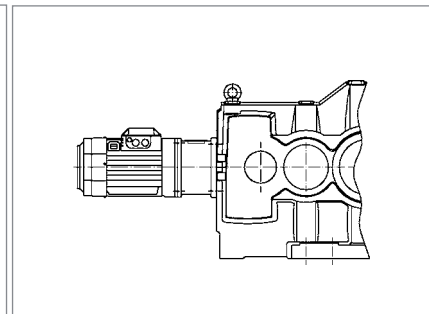

Motor flange, page 12.32

Size	LSS dimensions in mm																
	Solid shaft								Hollow shaft								
	d2	b2	h2	m2 ¹⁾	Y2	U2	V2	UD	U3	UC	ØD4	ØD5	US	ØD2	ØD3	ØD6	ØD7
100	310m6	70h9	324	M24	380	391	771	361	376	570	300	299	361	280	279	315	279
110	330m6	70h9	344	M30	380	416	796	386	401	600	320	319	386	290	289	325	289
120	350m6	80h9	365	M30	450	447	897	416	432	650	330	329	416	300	299	340	299
130	370m6	80h9	385	M30	450	479	929	451	464	690	380	379	446	340	339	385	339
140	390m6	90h9	407	M30	540	510	1050	482	495	745	400	399	481	360	359	400	359
150	410m6	90h9	427	M30	540	534	1074	506	519	800	450	449	501	400	399	450	399
160	430m6	90h9	447	M30	540	564	1104	536	549	830	460	459	531	420	419	465	419

In case of Through going LSS, same dimensions apply.

1) 2x180°, distance 0.6 x d2

Other available accessories, see section 12

Lubrication and Cooling	Page
Shaft end pump	12.24
Oil heating system	12.27
Optional seal arrangements	12.30
Lip seal on HSS and LSS	2)

Coupled equipment	Page
Couplings	*)
V-Belt drive	12.32

2) Standard Solution for this Gear Unit type
*) Contact Santasalo

See also modifications, page 12.35-12.37

4-stage bevel-helical gear units, horizontal LSS

Gear unit dimensions, type D4RHT

Torque arm mounting bracket with unmachined foot plane

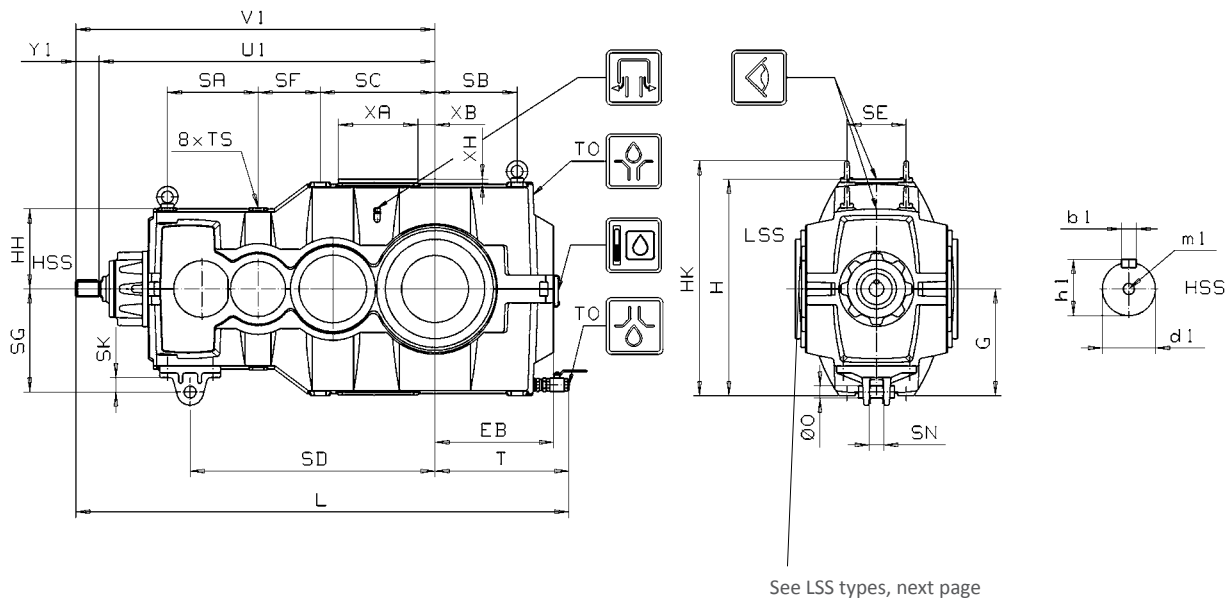

See LSS types, next page

Size	Torque arm mounting bracket																				
	EB	G	H	HH	HK	SA	SB	SC	SE	SF	T	TO	TS	XA	XB	XH	O	SD	SG	SK	SN
100	560	510	1020	375	1129	435	391	570	265	281	630	1 1/2"	M30	403	58	32	63	1190	470	75	70
110	620	560	1120	410	1248	480	440	640	290	290	690	1 1/2"	M36	403	86	32	63	1310	500	75	70
120	680	590	1180	465	1308	535	485	695	320	355	745	1 1/2"	M36	403	129	32	63	1475	555	75	70
130	730	650	1300	489	1447	580	530	760	360	360	795	1 1/2"	M42	403	129	32	63	1550	586	75	70
140	780	710	1420	520	1567	630	580	810	420	410	845	1 1/2"	M42	403	129	32	80	1650	675	120	90
150	750	750	1505	755	1537	0	0	0	0	0	925	1 1/2"	0	403	608	32	80	1767	650	120	90
160	800	800	1610	810	1642	0	0	0	0	0	975	1 1/2"	0	403	665	32	80	1910	700	120	90

Size	HSS dimensions in mm															Weight kg	Oil capacity		
	$i_n = 90...250$							$i_n = 280...315$							l		l		
	U1	Y1	V1	d1	b1	h1	m1	L	Y1	V1	d1	b1	h1	m1				L	
100	1596	125	1721	65m6	18h9	69	M20	2351	95	1691	55m6	16h9	59	M20	2321	3730	210	130	
110	1733	125	1858	70m6	20h9	74.5	M20	2548	95	1828	55m6	16h9	59	M20	2518	4830	275	155	
				$i_n = 90...200$							$i_n = 225...315$								
120	1992	150	2142	85m6	22h9	90	M20	2887	125	2117	70m6	20h9	74.5	M20	2862	6520	355	195	
130	2115	150	2265	95m6	25h9	100	M24	3060	125	2240	75m6	20h9	79.5	M20	3035	8330	560	235	
140	2258	190	2448	100m6	28h9	106	M24	3293	125	2383	75m6	20h9	79.5	M20	3228	9710	700	250	
150	2457	190	2647	110m6	28h9	116	M24	3572	150	2607	80m6	22h9	85	M20	3532	12400	860	280	
160	2640	190	2830	120m6	32h9	127	M24	3805	150	2790	90m6	25h9	95	M24	3765	14430	1030	320	

Shaft positions

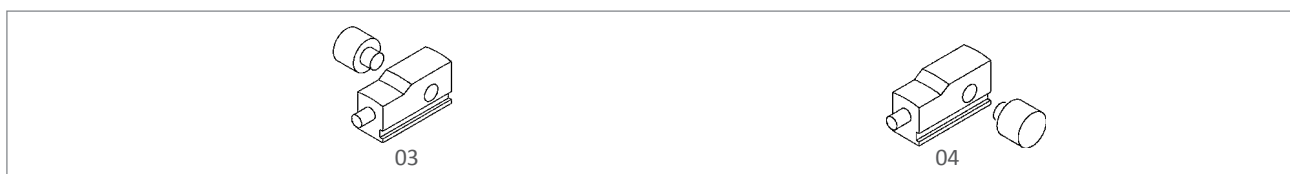

4-stage bevel-helical gear units, horizontal LSS

LSS types

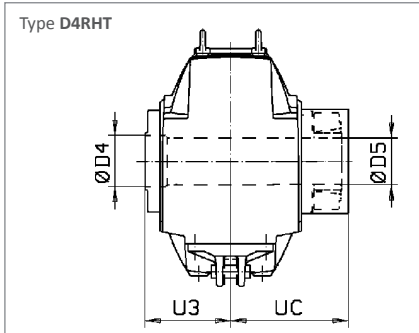

Hollow shaft, shrink disk, page 12.08

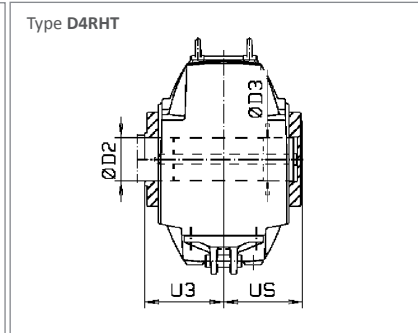

Hollow shaft, key connection, page 12.11

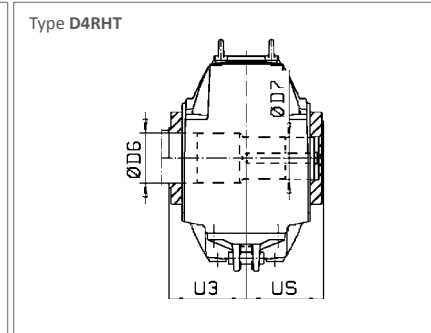

Hollow shaft, special key connection, page 12.12

Common accessories, see section 12

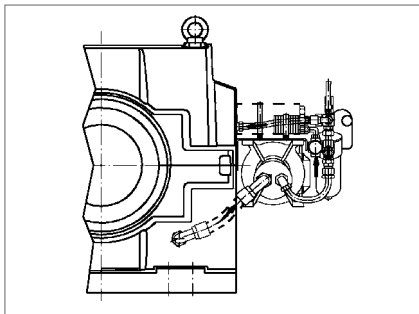

Lubrication unit, page 12.23

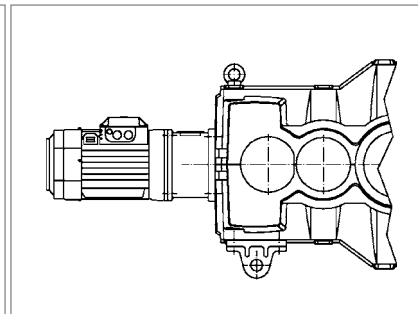

Motor flange, page 12.32

Size	LSS dimensions in mm								
	Hollow shaft								
	U3	UC	ØD4	ØD5	US	ØD2	ØD3	ØD6	ØD7
100	376	570	300	299	361	280	279	315	279
110	401	600	320	319	386	290	289	325	289
120	432	650	330	329	416	300	299	340	299
130	464	690	380	379	446	340	339	385	339
140	495	745	400	399	481	360	359	400	359
150	519	800	450	449	501	400	399	450	399
160	549	830	460	459	531	420	419	465	419

In case of Through going LSS, same dimensions apply.

Other available accessories, see section 12

Lubrication and Cooling	Page
Shaft end pump	12.24
Oil heating system	12.27
Optional seal arrangements	12.30
Lip seal on HSS and LSS	2)

Coupled equipment	Page
Couplings	*)
Torque arm	12.31
V-Belt drive	12.32

See also modifications, page 12.35-12.37

2) Standard Solution for this Gear Unit type
*) Contact Santasalo

4-stage bevel-helical gear units, horizontal LSS

Gear unit dimensions, type D4RUHT

Torque arm mounting bracket with unmachined foot plane

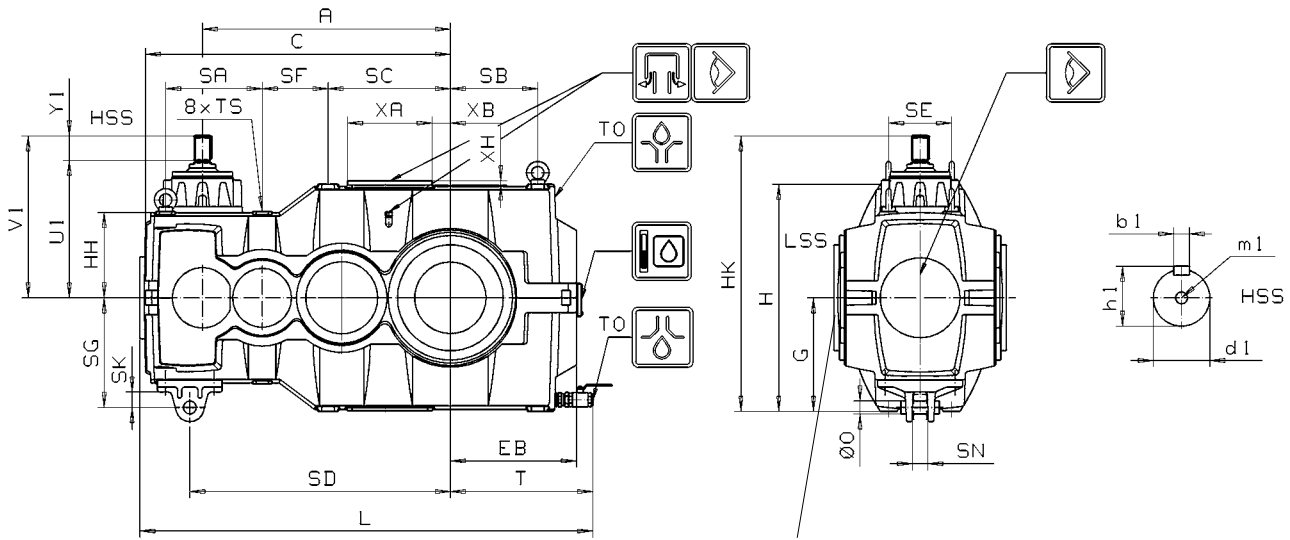

See LSS types, next page

Size	Housing dimensions in mm																		Torque arm mounting bracket					
	A	C	EB	G	H	HH	HK	L	SA	SB	SC	SE	SF	T	TO	TS	XA	XB	XH	O	SD	SG	SK	SN
100	1116	1386	560	510	1020	375	1129	2024	435	391	570	265	281	630	1 1/2"	M30	403	58	32	63	1190	470	75	70
110	1233	1510	620	560	1120	410	1248	2209	480	440	640	290	290	690	1 1/2"	M36	403	86	32	63	1310	500	75	70
120	1366	1700	680	590	1180	465	1308	2451	535	485	695	320	355	745	1 1/2"	M36	403	129	32	63	1475	555	75	70
130	1475	1815	730	650	1300	489	1447	2614	580	530	760	360	360	795	1 1/2"	M42	403	129	32	63	1550	586	75	70
140	1593	1973	780	710	1420	520	1567	2818	630	580	810	420	410	845	1 1/2"	M42	403	129	32	80	1650	675	120	90
150	1707	2052	750	750	1505	390	1537	2995	0	0	0	0	0	925	1 1/2"	0	403	608	32	80	1767	650	120	90
160	1840	2230	800	800	1610	420	1642	3225	0	0	0	0	0	975	1 1/2"	0	403	665	32	80	1910	700	120	90

Size	HSS dimensions in mm														Weight	Oil capacity	
	$i_n = 90...250$							$i_n = 280...315$								kg	Splash lubrication
	U1	Y1	V1	d1	b1	h1	m1	Y1	V1	d1	b1	h1	m1				
100	480	125	605	65m6	18h9	69	M20	95	575	55m6	16h9	59	M20	3730	-	130	
110	500	125	625	70m6	20h9	74.5	M20	95	595	55m6	16h9	59	M20	4830	-	155	
120	626	150	776	85m6	22h9	90	M20	125	751	70m6	20h9	74.5	M20	6520	-	195	
130	640	150	790	95m6	25h9	100	M24	125	765	75m6	20h9	79.5	M20	8330	-	235	
140	665	190	855	100m6	28h9	106	M24	125	790	75m6	20h9	79.5	M20	9710	-	250	
150	750	190	940	110m6	28h9	116	M24	150	900	80m6	22h9	85	M20	12400	-	280	
160	800	190	990	120m6	32h9	127	M24	150	950	90m6	25h9	95	M24	14430	-	320	

Shaft positions



4-stage bevel-helical gear units, horizontal LSS

LSS types

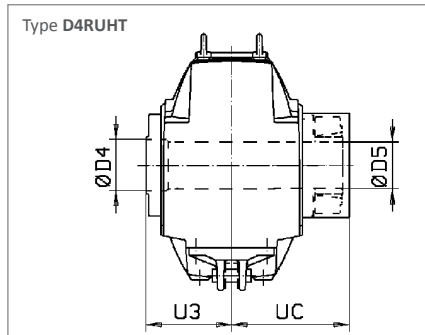

Hollow shaft, shrink disk, page 12.08

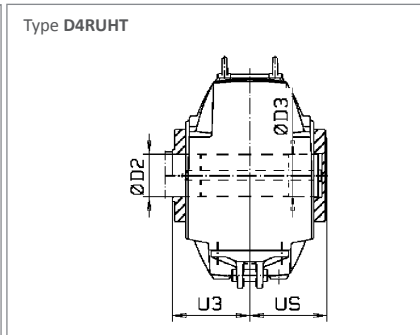

Hollow shaft, key connection, page 12.11

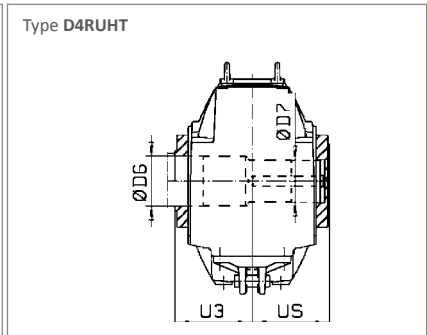

Hollow Shaft, Special Key Connection, page 12.12

Common accessories, see section 12

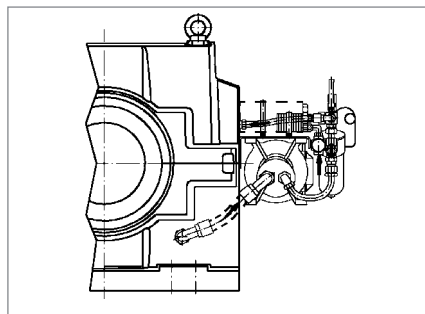

Lubrication unit, page 12.23

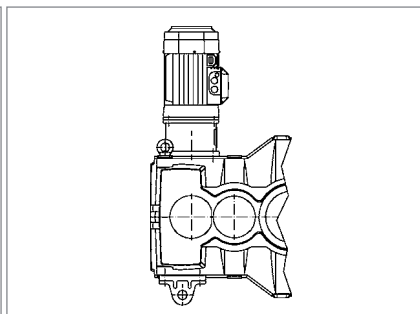

Motor flange, page 12.32

Size	LSS dimensions in mm								
	Hollow shaft								
	U3	UC	ØD4	ØD5	US	ØD2	ØD3	ØD6	ØD7
100	376	570	300	299	361	280	279	315	279
110	401	600	320	319	386	290	289	325	289
120	432	650	330	329	416	300	299	340	299
130	464	690	380	379	446	340	339	385	339
140	495	745	400	399	481	360	359	400	359
150	519	800	450	449	501	400	399	450	399
160	549	830	460	459	531	420	419	465	419

In case of Through going LSS, same dimensions apply.

Other available accessories, see section 12

Lubrication and Cooling	Page
Shaft end pump	12.24
Oil heating system	12.27
Optional seal arrangements	12.30
Lip seal on HSS and LSS	2)

Coupled equipment	Page
Couplings	*)
Torque arm	12.31
V-Belt drive	12.32

See also modifications, page 12.35-12.37

2) Standard Solution for this Gear Unit type
 *) Contact Santasalo

5-stage bevel-helical gear units

Gear unit dimensions, type 5KC160N-250N

Foot mounting face machined for foot mounting

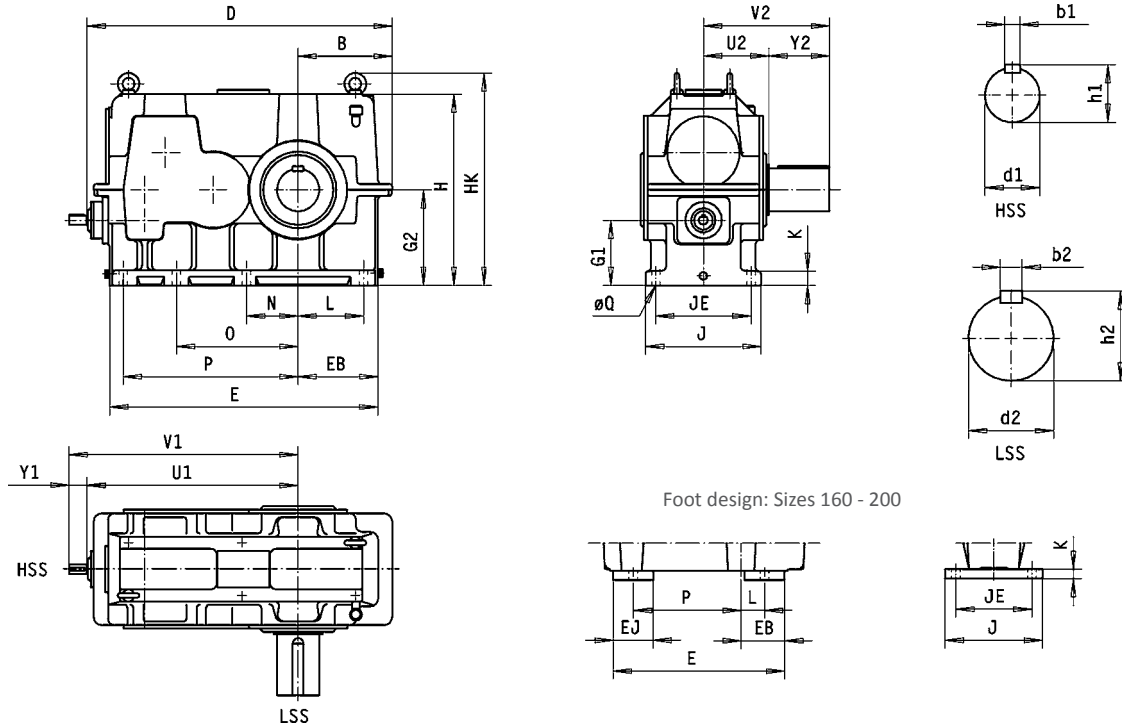

Foot design: Sizes 160 - 200

Size	Gear case dimensions in mm																
	B	D	E	EB	EJ	G1	G2	H	HK	J	JE	K	L	N	O	P	Q
160N	175	630	468	113	125	145	225	425	478	260	210	25	50	-	-	292	24
180N	205	695	521	131	140	170	250	475	537	280	225	25	60	-	-	320	24
200N	225	755	582	152	150	200	280	530	592	320	250	30	77	-	-	355	28
225N	255	830	692	200	-	200	280	560	631	325	265	40	165	135	-	455	28
250N	281	901	771	225	-	190	280	560	631	355	286	45	192	145	-	510	28

Size	Shaft dimensions in mm																	Weight kg	Quantity of oil l					
	Input shaft											Output shaft												
	$i_N=95...475$				$i_N=475...850$				$i_N=850...1900$			U2	Y2	V2	d2	b2	h2							
	U1	Y1	V1	d1	b1	h1	Y1	V1	d1	b1	h1	Y1	V1	d1	b1	h1	U2	Y2	V2	d2	b2	h2		
160N	455	42	497	28k6	8h9	31	36	491	20k6	6h9	22.5	25	480	14k6	5h9	16	140	105	245	75m6	20h9	79.5	160	9
180N	490	42	532	28k6	8h9	31	36	526	20k6	6h9	22.5	25	515	14k6	5h9	16	145	130	275	85m6	22h9	90	220	12
200N	530	42	572	28k6	8h9	31	36	566	20k6	6h9	22.5	25	555	14k6	5h9	16	155	130	285	95m6	25h9	100	300	17
225N	575	42	617	28k6	8h9	31	36	611	20k6	6h9	22.5	25	600	14k6	5h9	16	175	165	340	110m6	28h9	116	410	30
250N	620	42	662	28k6	8h9	31	36	656	20k6	6h9	22.5	25	645	14k6	5h9	16	195	165	360	120m6	32h9	127	550	40

Shaft positions

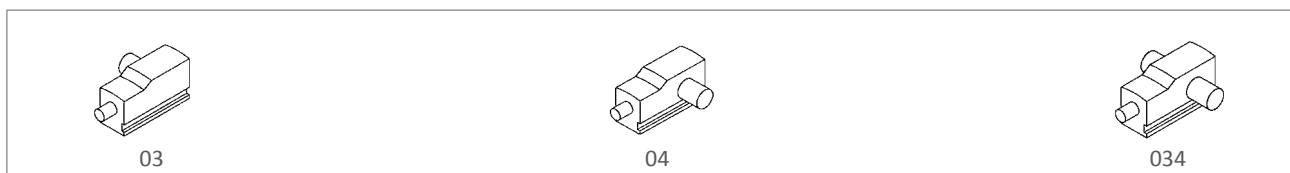

5-stage bevel-helical gear units

Gear unit dimensions, type 5TKC160N-250N

Torque arm mounting bracket with unmachined foot plane

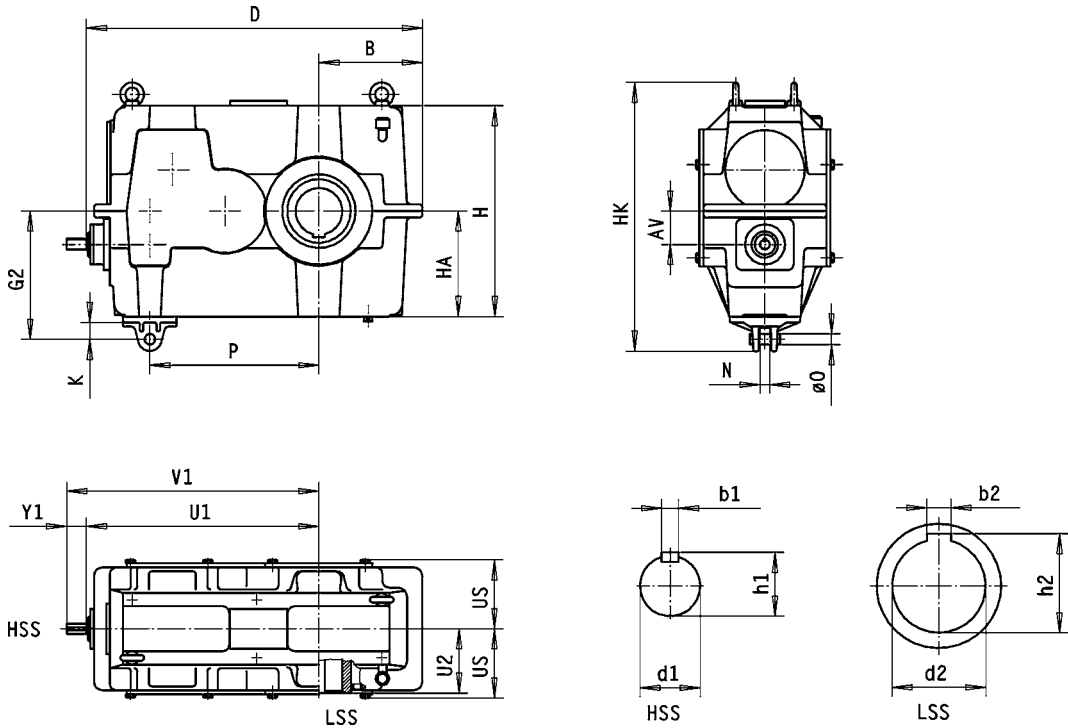

The dimensions of the hollow shaft hole: Page 12.01

Size	Gear case dimensions in mm												Weight	Quantity of oil
	AV	B	D	G2	H	HA	HK	K	N	O	P	US	kg	l
160N	80	175	630	243	400	200	521	28	20	22h9	285	131	160	9
180N	80	205	695	273	450	225	585	28	20	22h9	320	139	220	12
200N	80	225	755	298	500	250	635	28	20	22h9	360	149	300	17
225N	80	255	830	343	560	280	729	38	32	32h9	405	167	410	23
250N	90	281	901	346	560	280	729	38	32	32h9	450	187	550	26

Size	Shaft dimensions in mm																Hollow shaft			
	Input shaft																			
	$i_n=95...475$				$i_n=475...850$				$i_n=850...1900$				U2	d2	b2	h2				
	U1	Y1	V1	d1	b1	h1	Y1	V1	d1	b1	h1	Y1	V1	d1	b1	h1				
160N	455	42	497	28k6	8h9	31	36	491	20k6	6h9	22.5	25	480	14k6	5h9	16	118	80H8	22JS9	85.4
180N	490	42	532	28k6	8h9	31	36	526	20k6	6h9	22.5	25	515	14k6	5h9	16	125	90H8	25JS9	95.4
	$i_n=95...600$				$i_n=600...1060$				$i_n=1060...1900$											
200N	530	42	572	28k6	8h9	31	36	566	20k6	6h9	22.5	25	555	14k6	5h9	16	135	100H8	28JS9	106.4
225N	575	42	617	28k6	8h9	31	36	611	20k6	6h9	22.5	25	600	14k6	5h9	16	154	110H8	28JS9	116.4
250N	620	42	662	28k6	8h9	31	36	656	20k6	6h9	22.5	25	645	14k6	5h9	16	172	120H8	32JS9	127.4

Shaft positions

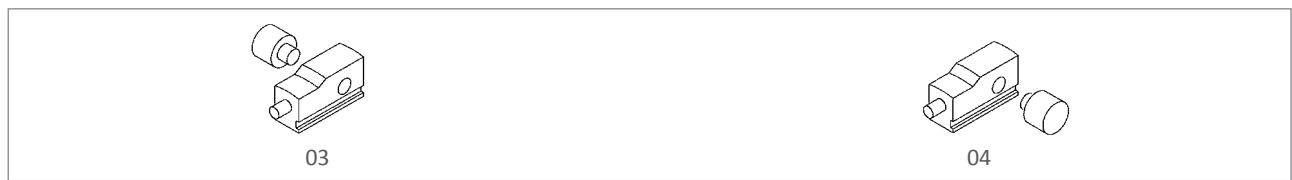

5-stage bevel-helical gear units

Gear unit dimensions, type D5RSF D5RHF D5RHT

Foot mounting face machined for foot mounting, type D5RSF D5RHF

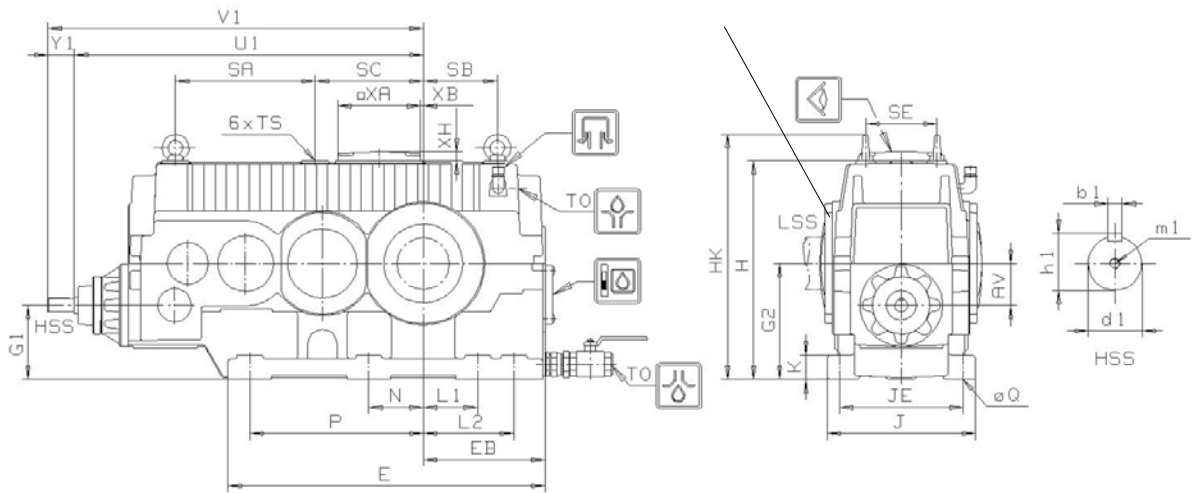

Torque arm mounting bracket with unmachined foot plane, type D5RHT

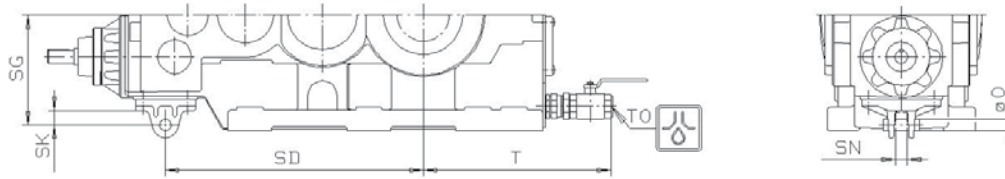

Size	Housing dimensions in mm																		Foot mounting Type D5RSF D5RHF						
	AV	E	EB	G1	G2	H	HK	J	K	SA	SB	SC	SE	TS	TO	T	XA	XB	XH	JE	L1	L2	N	P	Q
50	111.6	846	325	198.4	310	585	656	396	65	373	198	288	188	M20x35	1½	500	220	7	30	330	148	245	145	463	28
60	111.6	974	373	238.4	350	665	755	460	73	420	245	325	216	M24x42	1½	548	220	40	30	378	170	300	168	533	35
70	148.7	1135	427	251.3	400	760	850	506	82	475	292	418	250	M24x42	1½	602	260	92	30	416	194	322	190	633	35
80	148.7	1230	470	291.3	440	835	944	552	90	541	328	395	280	M30x53	1½	645	260	62	30	454	209	369	209	666	42
90	151.4	1324	512	328.6	480	910	1019	584	97	531	361	525	305	M30x53	1½	687	260	192	30	480	228	418	228	719	42

Size	HSS dimensions in mm													Torque arm mounting bracket Type D5RHT					Weight kg	Oil capacity	
	iN=355...900							iN=1000...1800						O	SD	SG	SK	SN		Splash lubrication	Pressure lubrication
	U1	Y1	V1	d1	b1	h1	m1	Y1	V1	d1	b1	h1	m1						l	l	
50	931	70	1001	35k6	10h9	38	M12	70	1001	30k6	8h9	33	M10	32	693	294	38	32	900	57	57
60	1018	70	1088	35k6	10h9	38	M12	70	1088	30k6	8h9	33	M10	45	775	308	52	45	1295	83	83
70	1198	95	1293	45k6	14h9	48.5	M16	70	1268	35k6	10h9	38	M12	45	928	380	52	45	1820	125	125
80	1248	95	1343	45k6	14h9	48.5	M16	70	1318	35k6	10h9	38	M12	45	978	380	52	45	2270	160	160
90	1377	95	1472	45k6	14h9	48.5	M16	70	1447	35k6	10h9	38	M12	45	1107	389	52	45	2980	208	208

Shaft positions

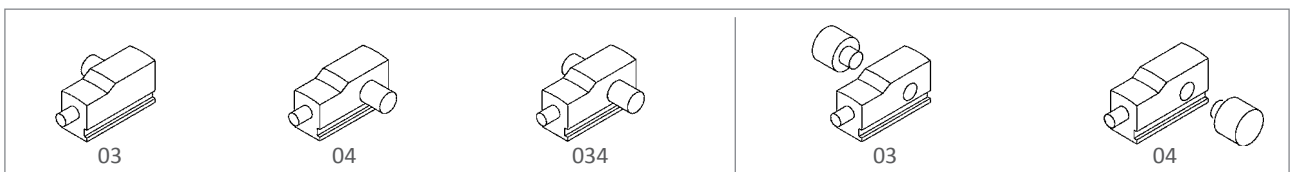

5-stage bevel-helical gear units

LSS types

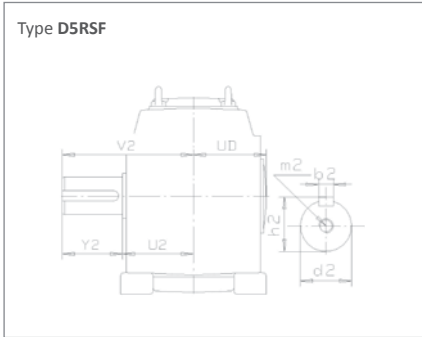

Solid shaft

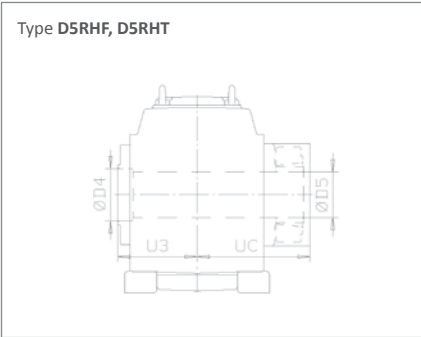

Hollow shaft, shrink disk, page 12.07

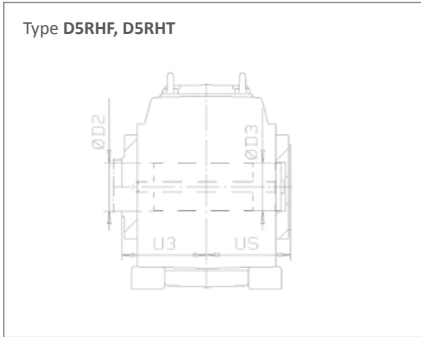

Hollow shaft, key connection, page 12.10

Common accessories, see section 12

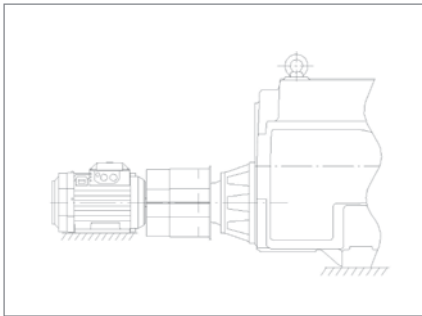

Coupling guard, page 12.31

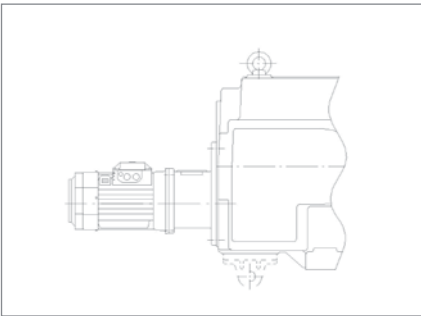

Motor flange, page 12.32

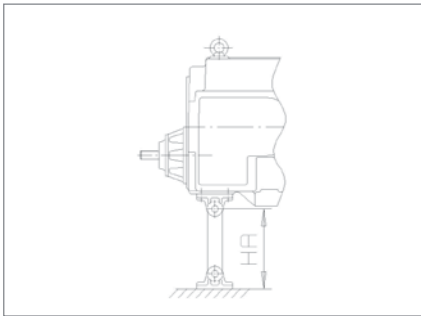

Torque arm, page 12.31

Size	LSS dimensions in mm														Common accessories		
	d2	b2	h2	m2	Y2	U2	V2	UD	U3	UC	D4	D5	US	D2	D3	HAmín	HAmáx
50	140m6	36h9	148	M30	200	232	432	216	228	336	155	154	232	150	149	125	950
60	160m6	40h9	169	M30	240	261	501	245	255	386	180	179	259	170	169	175	1070
70	180m6	45h9	190	M30	240	281	521	274	284	422	190	189	288	190	189	175	1070
80	200m6	45h9	210	+)	280	315	595	290	302	453	210	209	306	210	209	175	1070
90	220m6	50h9	231	+)	280	337	617	314	324	501	250	249	328	240	239	175	1070

Other available accessories, see section 12

Lubrication and Cooling	Page
Shaft end pump	12.24
Oil heating system	12.27
Optional seal arrangements	12.30
Lip seal on HSS and LSS	2)

Coupled equipment	Page
Couplings	*)
Torque arm	12.31
V-Belt drive	12.32

See also modifications, page 12.35-12.37

2) Standard Solution for this Gear Unit type
 *) Contact Santasalo

5 -stage bevel-helical gear units, horizontal LSS

Gear unit dimensions, type D5RSF D5RHF

Foot mounting face machined for foot mounting

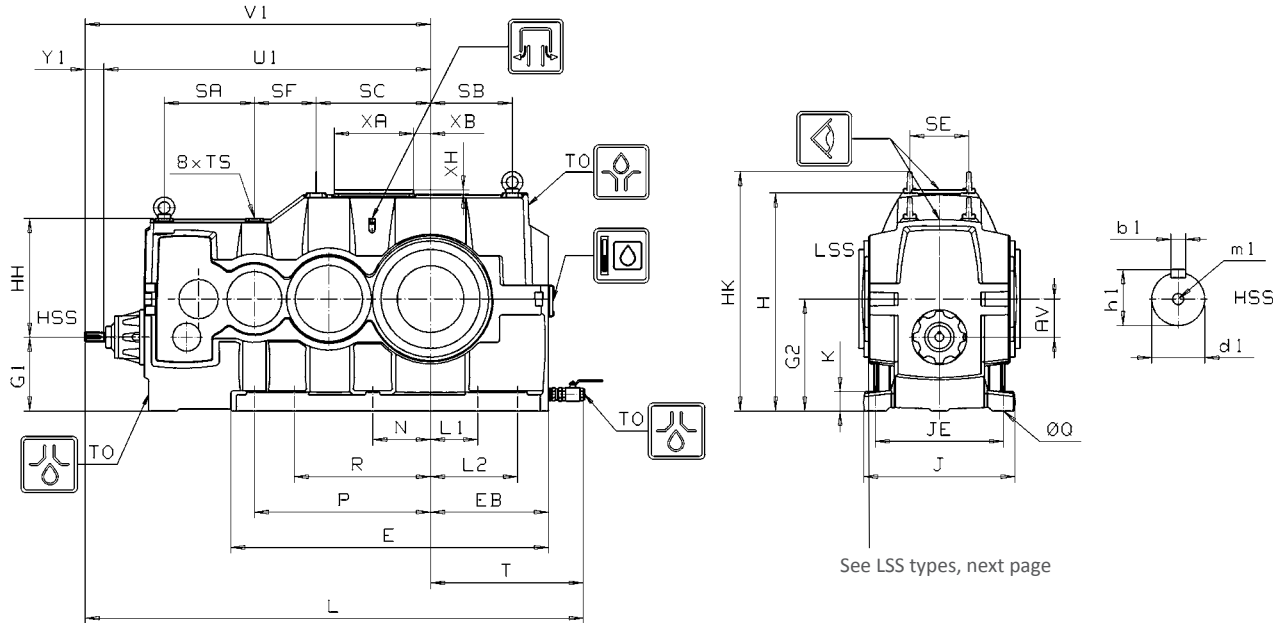

Size	Housing dimensions in mm																	Foot mounting										
	AV	E	EB	G1	G2	H	HH	HK	J	K	SA	SB	SC	SE	SF	T	TO	TS	XA	XB	XH	JE	L1	L2	N	P	Q	R
100	176.6	1496	560	363.4	540	1050	375	1159	690	100	435	391	570	265	281	735	1 1/2"	M30	403	58	32	580	300	420	300	850	48	730
110	193.9	1658	620	376.1	570	1130	410	1258	750	100	480	440	640	290	290	795	1 1/2"	M36	403	86	32	640	340	480	340	950	54	770
120	202.8	1836	680	407.2	610	1200	465	1328	810	103	535	485	695	320	355	855	1 1/2"	M36	403	129	32	690	340	540	340	1060	54	880
130	224.3	1984	730	425.7	680	1330	489	1477	860	103	580	530	760	360	360	905	1 1/2"	M42	403	129	32	740	390	590	390	1135	54	935
140	230.2	2115	780	499.8	730	1440	520	1587	914	110	630	580	810	420	410	955	1 1/2"	M42	403	129	32	794	440	660	394	1234	54	1035
150	264.3	2357	750	505.7	770	1525	755	1557	942	95	0	0	0	0	925	1 1/2"	0	403	608	32	822	300	620	428	1476	54	1156	
160	289.7	2540	800	530.3	820	1630	810	1662	1002	95	0	0	0	0	975	1 1/2"	0	403	665	32	862	300	670	470	1610	54	1240	

Size	HSS dimensions in mm															Weight		Oil capacity	
	$i_n=355...800$					$i_n=900...1800$					D5RSF/D5RHF		Splash lubrication	Pressure lubrication					
	U1	Y1	V1	d1	b1	h1	m1	L	Y1	V1	d1	b1	h1	m1	L	kg	l	l	
100	1556	95	1651	50k6	14h9	53.5	M16	2386	95	1651	40k6	12h9	43	M16	2386	4450/3920	285	130	
110	1700	95	1795	55m6	16h9	59	M20	2590	95	1795	45k6	14h9	48.5	M16	2590	5540/4920	370	155	
120	1912	125	2037	60m6	18h9	64	M20	2892	95	2007	50k6	14h9	53.5	M16	2862	7240/6530	490	195	
	$i_n=355...710$					$i_n=800...1800$													
130	2025	125	2150	65m6	18h9	69	M20	3055	95	2120	55m6	16h9	59	M20	3025	8980/8330	635	235	
140	2143	125	2268	70m6	20h9	74.5	M20	3223	95	2238	55m6	16h9	59	M20	3193	11070/9940	830	290	
150	2286	125	2411	75m6	20h9	79.5	M20	3336	125	2411	60m6	18h9	64	M20	3336	13650/12720	1010	320	
160	2536	150	2686	85m6	22h9	90	M20	3661	125	2661	70m6	20h9	74.5	M20	3636	15820/14820	1220	380	

Shaft positions

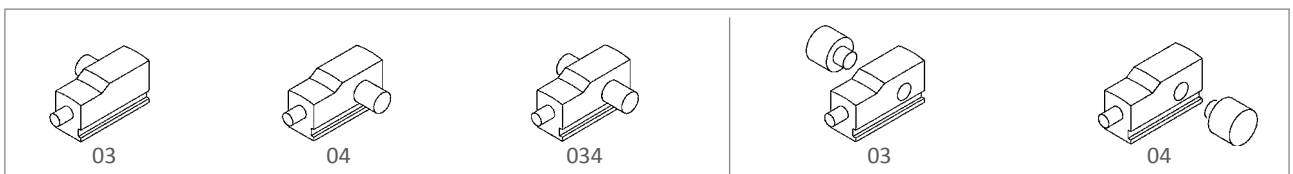

5-stage bevel-helical gear units, horizontal LSS

LSS types

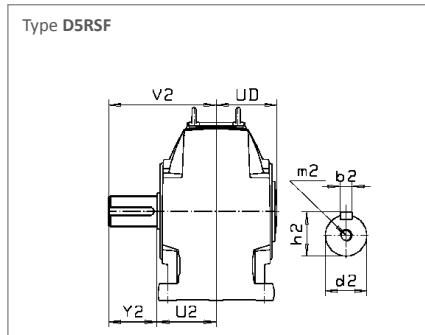

Solid shaft

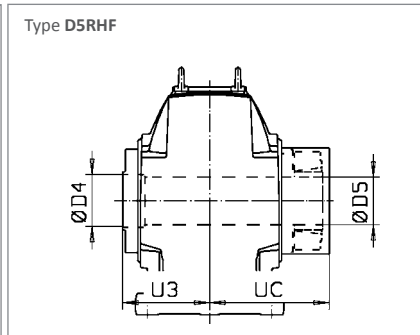

Hollow shaft, shrink disk, page 12.08

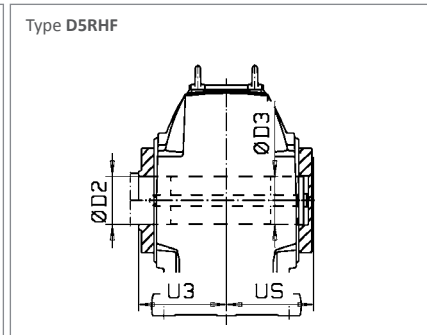

Hollow shaft, key connection, page 12.11

Common accessories, see section 12

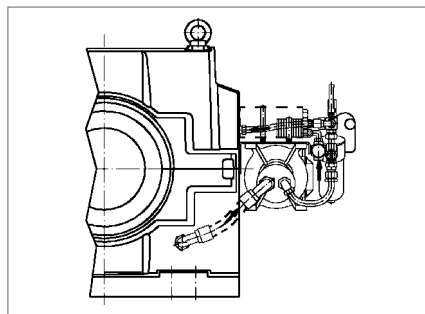

Lubrication unit, page 12.23

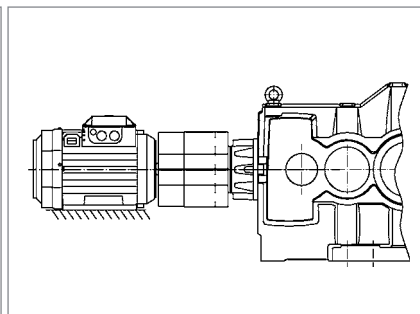

Coupling guard, page 12.31

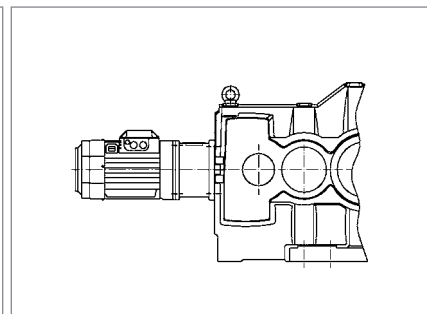

Motor flange, page 12.32

Size	LSS dimensions in mm																
	Solid shaft								Hollow shaft								
	d2	b2	h2	m2 ¹⁾	Y2	U2	V2	UD	U3	UC	ØD4	ØD5	US	ØD2	ØD3	ØD6	ØD7
100	310m6	70h9	324	M24	380	391	771	361	376	570	300	299	361	280	279	315	279
110	330m6	70h9	344	M30	380	416	796	386	401	600	320	319	386	290	289	325	289
120	350m6	80h9	365	M30	450	447	897	416	432	650	330	329	416	300	299	340	299
130	370m6	80h9	385	M30	450	479	929	451	464	690	380	379	446	340	339	385	339
140	390m6	90h9	407	M30	540	510	1050	482	495	745	400	399	481	360	359	400	359
150	410m6	90h9	427	M30	540	534	1074	506	519	800	450	449	501	400	399	450	399
160	430m6	90h9	447	M30	540	564	1104	536	549	830	460	459	531	420	419	465	419

In case of Through going LSS, same dimensions apply.

1) 2x180°, distance 0.6 x d2

Other available accessories, see section 12

Accessories	Page
Lubrication and Cooling	Page
Shaft end pump	12.24
Oil heating system	12.27
Optional seal arrangements	12.30
Lip seal on HSS and LSS	2)

Coupled equipment	Page
Couplings	*)
V-Belt drive	12.32

2) Standard Solution for this Gear Unit type
 *) Contact Santasalo

See also modifications, page 12.35-12.37

5-stage bevel-helical gear units, horizontal LSS

Gear unit dimensions, type D5RHT

Torque arm mounting bracket with unmachined foot plane.

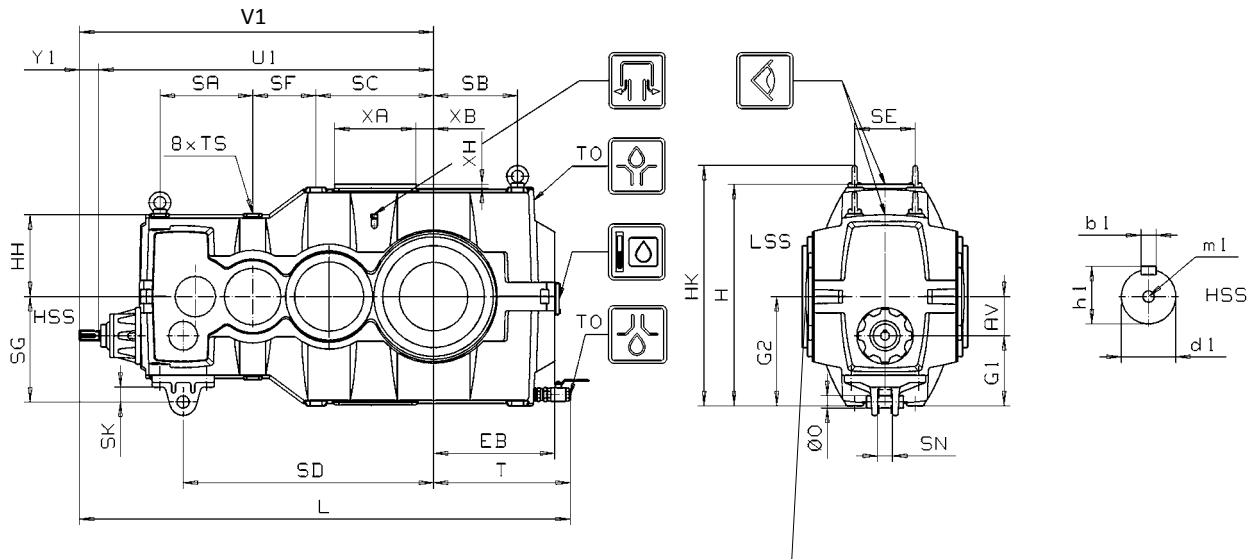

See LSS types, next page

Size	Housing dimensions in mm																	Torque arm mounting bracket					
	AV	EB	G1	G2	H	HH	HK	SA	SB	SC	SE	SF	T	TO	TS	XA	XB	XH	O	SD	SG	SK	SN
100	176.6	560	333.4	510	1020	375	1129	435	391	570	265	281	630	1 1/2"	M30	403	58	32	63	1190	470	75	70
110	193.9	620	366.1	560	1120	410	1248	480	440	640	290	290	690	1 1/2"	M36	403	86	32	63	1310	500	75	70
120	202.8	680	387.2	590	1180	465	1308	535	485	695	320	355	745	1 1/2"	M36	403	129	32	63	1475	555	75	70
130	224.3	730	425.7	650	1300	489	1447	580	530	760	360	360	795	1 1/2"	M42	403	129	32	63	1550	586	75	70
140	246.0	780	479.8	710	1420	520	1567	630	580	810	420	410	845	1 1/2"	M42	403	129	32	80	1650	610	120	90
150	264.3	750	485.7	750	1505	755	1537	0	0	0	0	0	925	1 1/2"	0	403	608	32	80	1767	650	120	90
160	289.7	800	510.3	800	1610	810	1642	0	0	0	0	0	975	1 1/2"	0	403	665	32	80	1910	700	120	90

Size	HSS dimensions in mm															Weight	Oil capacity	
	$i_N=355...800$					$i_N=900...1800$					kg	Splash lubrication	Pressure lubrication					
	U1	Y1	V1	d1	b1	h1	m1	L	Y1	V1		d1	b1	h1	m1	L	l	l
100	1556	95	1651	50k6	14h9	53.5	M16	2281	95	1651	40k6	12h9	43	M16	2281	3690	210	130
110	1700	95	1795	55m6	16h9	59	M20	2485	95	1795	45k6	14h9	48.5	M16	2485	4790	275	155
120	1912	125	2037	60m6	18h9	64	M20	2782	95	2007	50k6	14h9	53.5	M16	2752	6360	355	195
				$i_N=355...710$					$i_N=800...1800$									
130	2025	125	2150	65m6	18h9	69	M20	2945	95	2120	55m6	16h9	59	M20	2915	8100	560	235
140	2143	125	2268	70m6	20h9	74.5	M20	3113	95	2238	55m6	16h9	59	M20	3083	9450	700	250
150	2286	125	2411	75m6	20h9	79.5	M20	3336	125	2411	60m6	18h9	64	M20	3336	12170	860	280
160	2536	150	2686	85m6	22h9	90	M20	3661	125	2661	70m6	20h9	74.5	M20	3636	14200	1030	320

Shaft positions

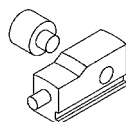

03

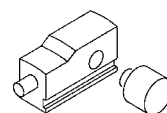

04

5-stage bevel-helical gear units, horizontal LSS

LSS types

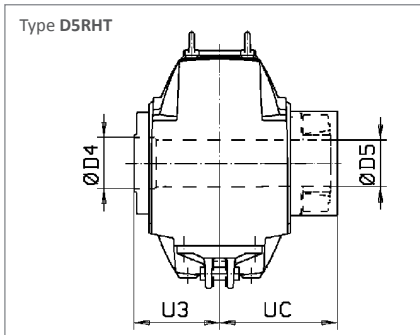

Hollow shaft, shrink disk, page 12.08

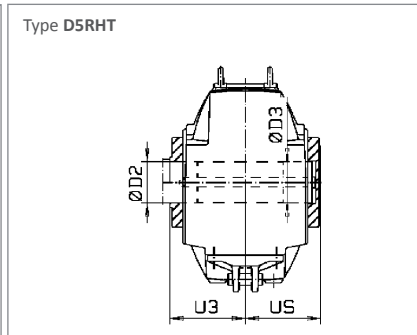

Hollow shaft, key connection, page 12.11

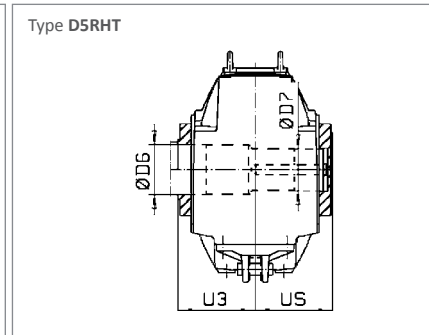

Hollow Shaft, Special Key Connection, page 12.12

Common accessories, see section 12

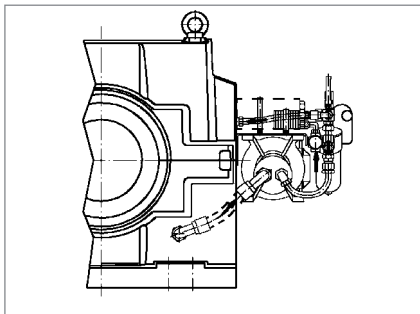

Lubrication unit, page 12.23

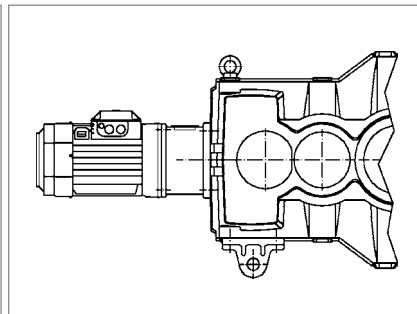

Motor flange, page 12.32

Size	LSS dimensions in mm								
	Hollow shaft								
	U3	UC	ØD4	ØD5	US	ØD2	ØD3	ØD6	ØD7
100	376	570	300	299	361	280	279	315	279
110	401	600	320	319	386	290	289	325	289
120	432	650	330	329	416	300	299	340	299
130	464	690	380	379	446	340	339	385	339
140	495	745	400	399	481	360	359	400	359
150	519	800	450	449	501	400	399	450	399
160	549	830	460	459	531	420	419	465	419

In case of Through going LSS, same dimensions apply.

Other available accessories, see section 12

Lubrication and Cooling	Page
Shaft end pump	12.24
Oil heating system	12.27
Optional seal arrangements	12.30
Lip seal on HSS and LSS	2)

Coupled equipment	Page
Couplings	*)
Torque arm	12.31
V-Belt drive	12.32

2) Standard Solution for this Gear Unit type
*) Contact Santasalo

See also modifications, page 12.35-12.37

5-stage bevel-helical gear units, horizontal LSS

Gear unit dimensions, type D5RUHT

Torque arm mounting bracket with unmachined foot plane

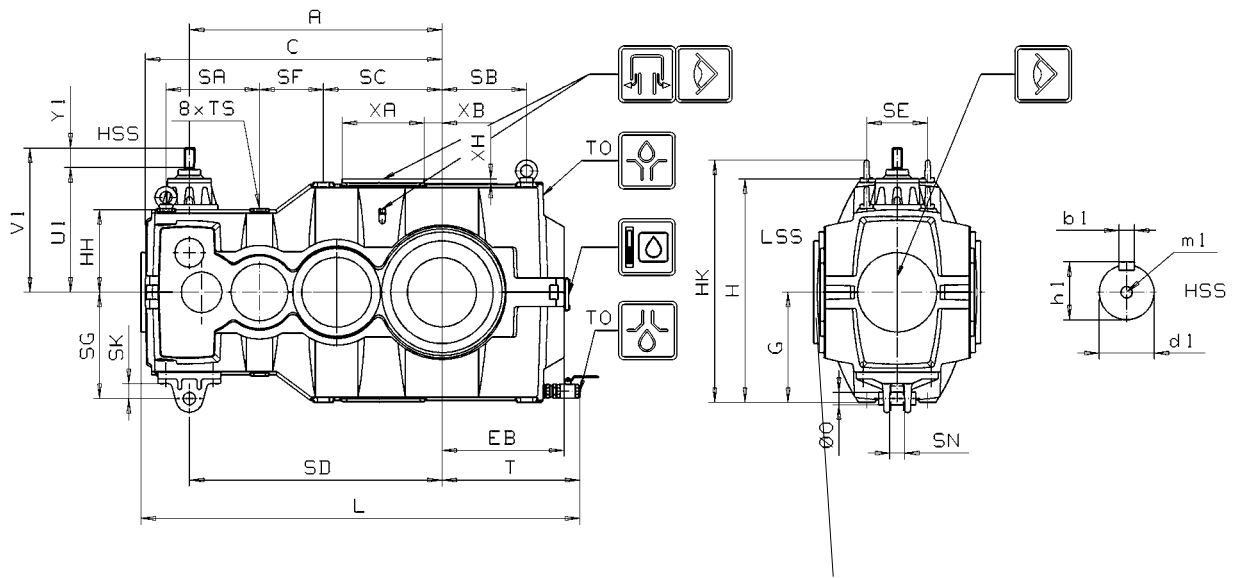

See LSS types, next page

Size	Housing dimensions in mm																	Torque arm mounting bracket						
	A	C	EB	G	H	HH	HK	L	SA	SB	SC	SE	SF	T	TO	TS	XA	XB	XH	O	SD	SG	SK	SN
100	1186	1386	560	510	1020	375	1129	2024	435	391	570	265	281	630	1 1/2"	M30	403	58	32	63	1190	470	75	70
110	1293	1510	620	560	1120	410	1248	2209	480	440	640	290	290	690	1 1/2"	M36	403	86	32	63	1310	500	75	70
120	1446	1700	680	590	1180	465	1308	2451	535	485	695	320	355	745	1 1/2"	M36	403	129	32	63	1475	555	75	70
130	1545	1815	730	650	1300	489	1447	2614	580	530	760	360	360	795	1 1/2"	M42	403	129	32	63	1550	586	75	70
140	1693	1973	780	710	1420	520	1567	2818	630	580	810	420	410	845	1 1/2"	M42	403	129	32	80	1650	610	120	90
150	1767	2052	750	750	1505	544	1537	2995	0	0	0	0	0	925	1 1/2"	0	403	608	32	80	1767	650	120	90
160	1910	2230	800	800	1610	605	1642	3225	0	0	0	0	0	975	1 1/2"	0	403	665	32	80	1910	700	120	90

Size	HSS dimensions in mm												Weight	Oil capacity		
	$i_n=355...800$						$i_n=900...1800$							Splash lubrication	Pressure lubrication	
	U1	Y1	V1	d1	b1	h1	m1	Y1	V1	d1	b1	h1	m1	kg	l	l
100	546.6	95	641.6	50k6	14h9	53.5	M16	95	641.6	40k6	12h9	43	M16	3690	-	130
110	600.9	95	695.9	55m6	16h9	59	M20	95	695.9	45k6	14h9	48.5	M16	4790	-	155
120	668.8	125	793.8	60m6	18h9	64	M20	95	763.8	50k6	14h9	53.5	M16	6360	-	195
130	704.3	125	829.3	65m6	18h9	69	M20	95	799.3	55m6	16h9	59	M20	8100	-	235
140	730.2	125	855.2	70m6	20h9	74.5	M20	95	825.2	55m6	16h9	59	M20	9450	-	250
150	783.3	125	908.3	75m6	20h9	79.5	M20	125	908.3	60m6	18h9	64	M20	12170	-	280
160	915.7	150	1065.7	85m6	22h9	90	M20	125	1040.7	70m6	20h9	74.5	M20	14200	-	320

Shaft positions

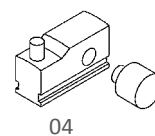
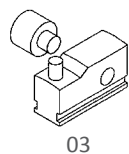

5-stage bevel-helical gear units, horizontal LSS

LSS types

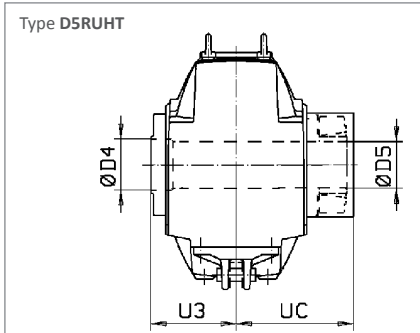

Hollow shaft, shrink disk, page 12.08

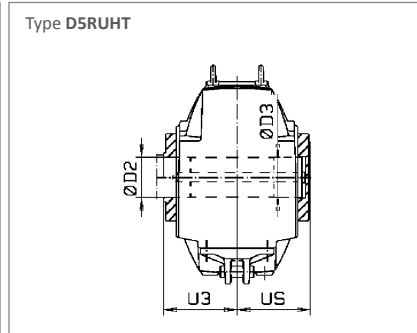

Hollow shaft, key connection, page 12.11

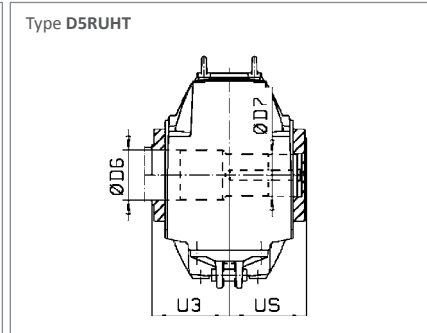

Hollow Shaft, Special Key Connection, page 12.12

Common accessories, see section 12

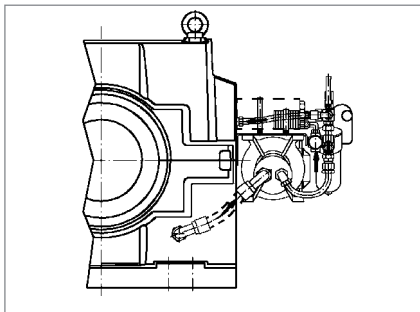

Lubrication unit, page 12.23

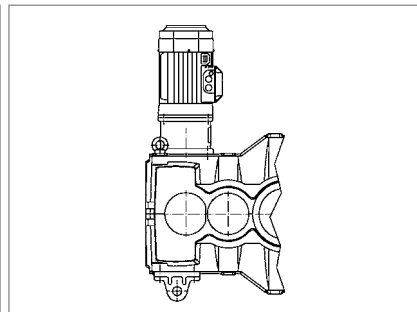

Motor flange, page 12.32

Size	LSS dimensions in mm								
	Hollow shaft								
	U3	UC	ØD4	ØD5	US	ØD2	ØD3	ØD6	ØD7
100	376	570	300	299	361	280	279	315	279
110	401	600	320	319	386	290	289	325	289
120	432	650	330	329	416	300	299	340	299
130	464	690	380	379	446	340	339	385	339
140	495	745	400	399	481	360	359	400	359
150	519	800	450	449	501	400	399	450	399
160	549	830	460	459	531	420	419	465	419

In case of Through going LSS, same dimensions apply.

Other available accessories, see section 12

Lubrication and Cooling	Page
Shaft end pump	12.24
Oil heating system	12.27
Optional seal arrangements	12.30
Lip seal on HSS and LSS	2)

Coupled equipment	Page
Couplings	*)
Torque arm	12.31
V-Belt drive	12.32

2) Standard Solution for this Gear Unit type
*) Contact Santasalo

See also modifications, page 12.35-12.37

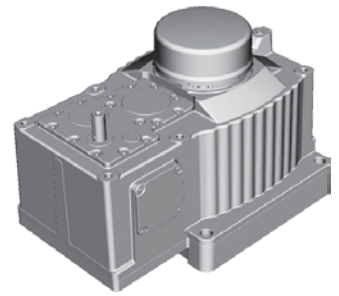
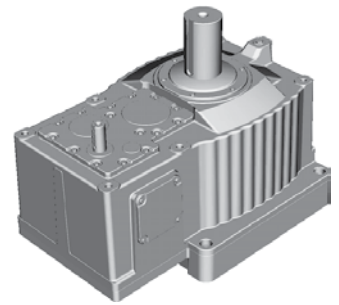

2-stage helical gear units, vertical LSS

Gear unit dimensions, type D2PVSF D2PVHF

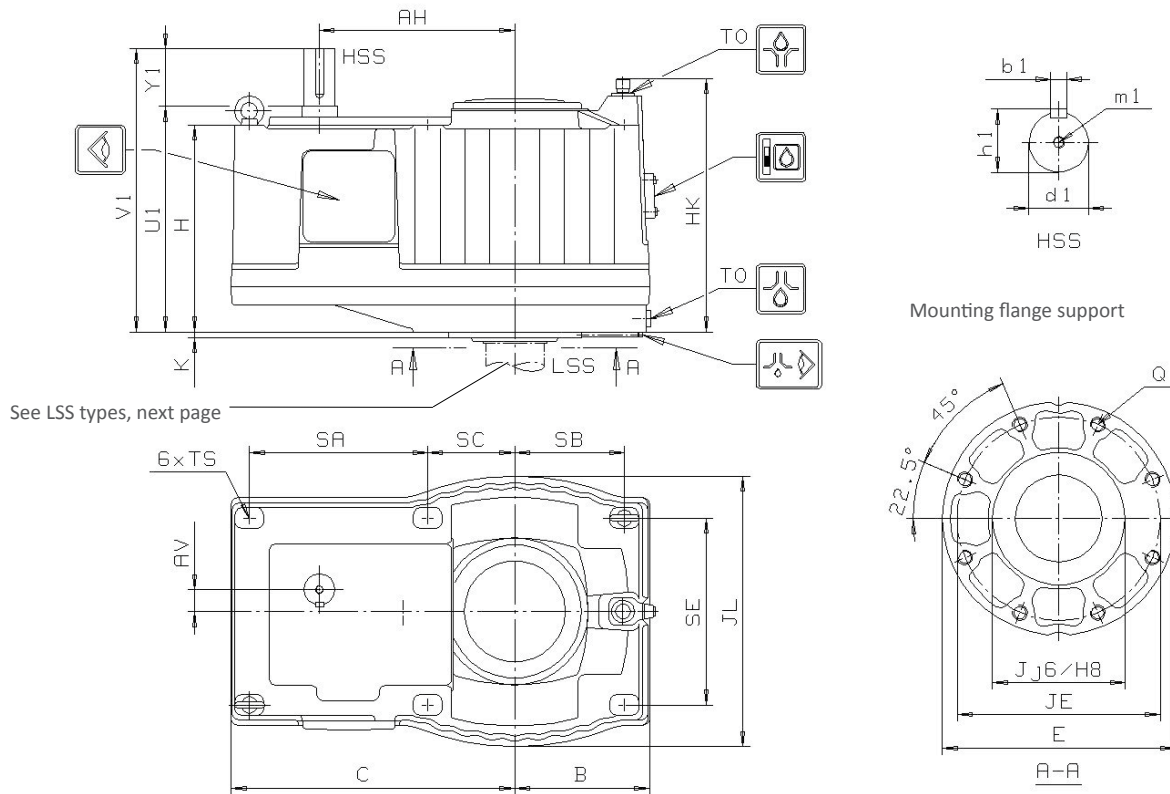

Size	Housing dimensions in mm																	
	AH	AV	B	C	E	H	HK	J	JE	JL	K	Q	SA	SB	SC	SE	TS	TO
10	266	33.8	195	402	315	314	451	200	275	390	10	M20x35	234	155	128	260	M16x32	1
20	278	42.5	210	414	348	328	474	215	300	420	10	M24x42	236	170	138	280	M16x32	1
30	353	42.6	242	522	400	393	548	270	340	484	12	M30x53	321	192	171	310	M20x35	1
40	396	51.4	275	566	460	431	589	280	400	550	12	M30x53	342	225	193	364	M20x35	1
50	471	53.0	325	682	562	499	634	320	490	650	12	M36x63	431	270	215	440	M24x42	1½

Size	HSS dimensions in mm							Weight	Oil capacity	
	$i_n = 6.3...18$								Bath lubrication	Pressure lubrication
	U1	Y1	V1	d1	b1	h1	m1	kg	l	l
10	348	70	418	35k6	10h9	38	M12	240	34	14
20	363	70	433	35k6	10h9	38	M12	290	39	16
30	430	95	525	45k6	14h9	48.5	M16	440	68	25
40	471	95	566	50k6	14h9	53.5	M16	670	94	34
50	539	125	664	65m6	18h9	69	M20	1020	152	51

Shaft positions

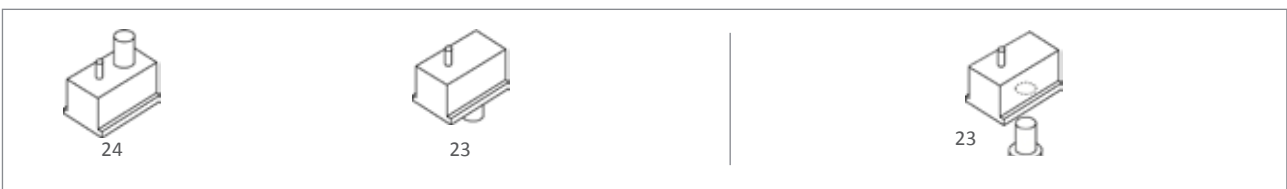

2-stage helical gear units, vertical LSS

LSS types

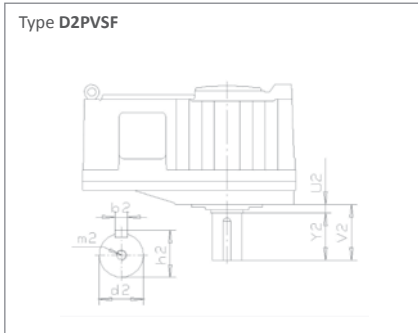

Solid shaft downwards

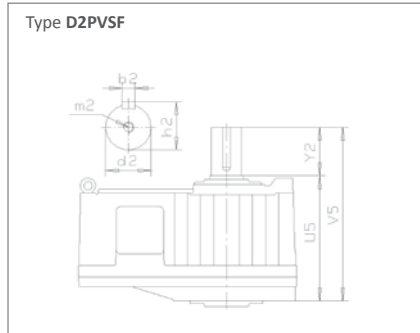

Solid shaft upwards

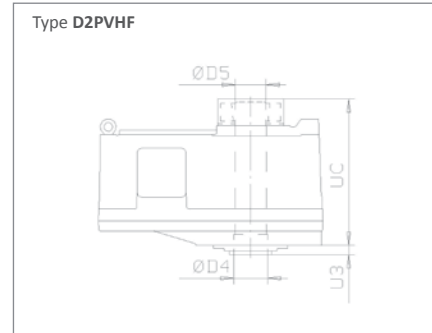

Hollow shaft, shrink disk, page 12.13

Common accessories, see section 12

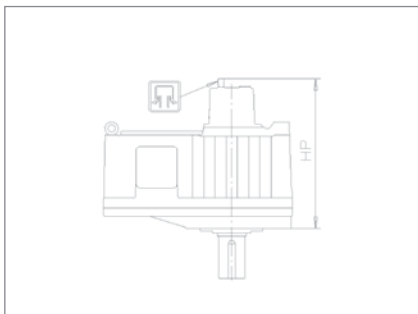

Expansion tank, with bath lubrication

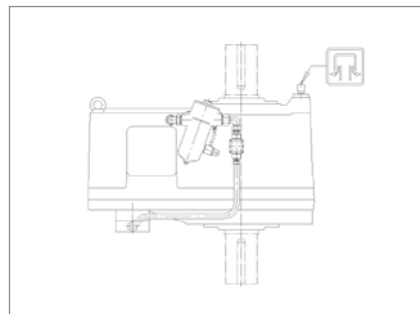

Shaft end pump, page 12.24, with pressure lubrication

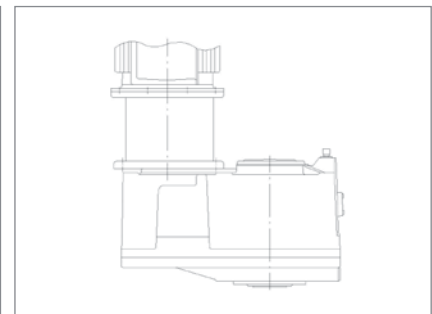

Motor flange, page 12.32

Size	LSS dimensions in mm													Common accessories
	Solid shaft					Hollow shaft								
	d2	b2	h2	m2	Y2	U2	V2	U5	V5	U3	UC	D4	D5	HP
10	85m6	22h9	90	M20	150	25	175	394	544	25	445	85	84	547
20	90m6	25h9	95	M24	150	25	175	415	565	25	470	95	94	570
30	110m6	28h9	116	M24	190	25	215	493	683	25	555	120	119	648
40	120m6	32h9	127	M24	190	25	215	534	724	25	600	130	129	725
50	140m6	36h9	148	M30	225	25	250	597	822	25	700	155	154	825

Other available accessories, see section 12

Mounting flange	12.17
Lubrication	Page
Lubrication unit	12.23
Oil heating system 3)	12.27
Oil drain valves	12.28
Expansion tank for moist environment	12.29

Optional seal arrangements	12.30
Lip seal on HSS and LSS	2)
Coupled equipment	Page
Couplings	*)
Belt drive	12.32

2) Standard solution for this gear unit type
3) For gear unit size 50
*) Contact Santasalo

See also modifications, page 12.35-12.37

2-stage helical gear units, vertical LSS

Gear unit dimensions, type D2PVSF D2PVHF

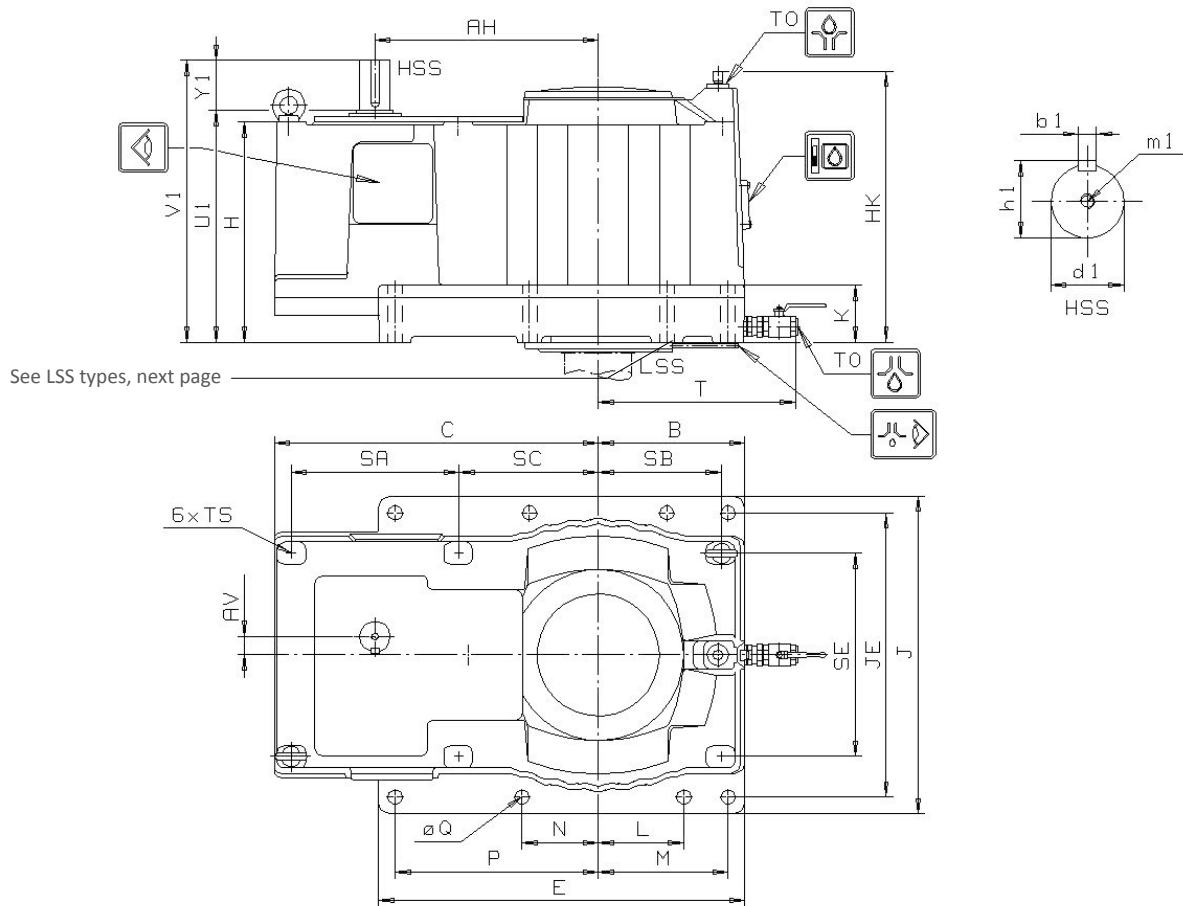

See LSS types, next page

Size	Housing dimensions in mm																					
	AH	AV	B	C	E	H	HK	J	JE	K	L	M	N	P	Q	SA	SB	SC	SE	TS	TO	T
60	531	82.6	405	778	810	570	711	810	700	165	-	350	-	350	48	397	343	343	486	M24x42	1½	572
70	614	69.0	405	906	1010	620	771	920	810	171	-	350	235	550	48	480	343	388	576	M24x42	1½	572
80	665	67.1	440	959	1100	662	823	1000	890	182	235	385	235	605	48	481	367	427	608	M30x53	1½	607

Size	HSS dimensions in mm							Weight	Oil capacity	
	$i_n=6.3...18$								kg	Bath lubrication
	U1	Y1	V1	d1	b1	h1	m1	l		l
60	610	125	735	75m6	20h9	79.5	M20	1480	183	61
70	666	150	816	90m6	25h9	95	M24	2060	263	86
80	709	150	859	95m6	25h9	100	M24	2570	353	122

Shaft positions

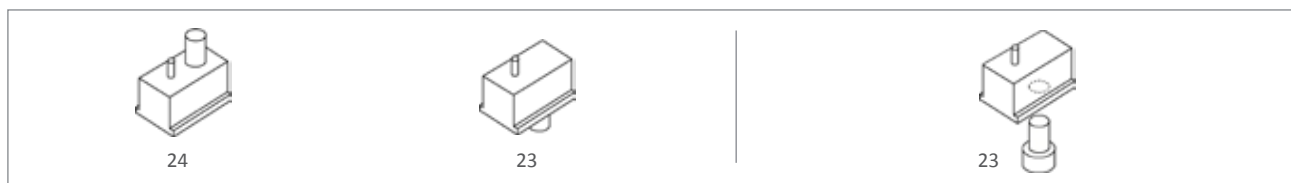

2-stage helical gear units, vertical LSS

LSS types

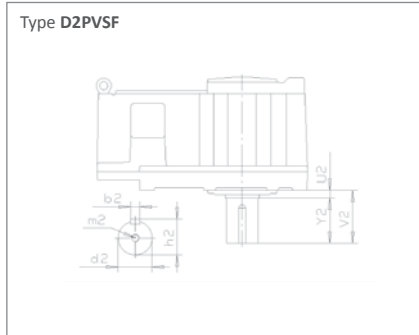

Solid shaft downwards

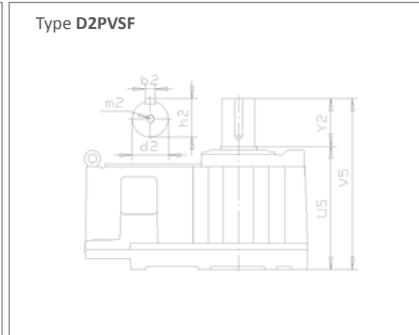

Solid shaft upwards

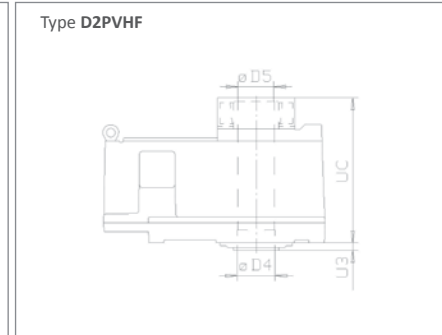

Hollow shaft, shrink disk, page 12.13

Common accessories, see section 12

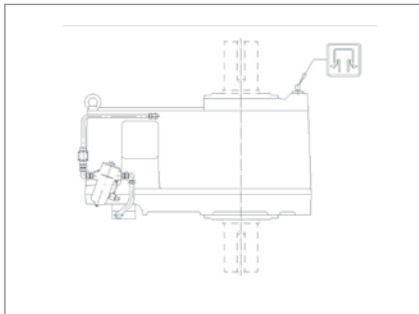

Shaft end pump,
page 12.24 with Pressure Lubrication

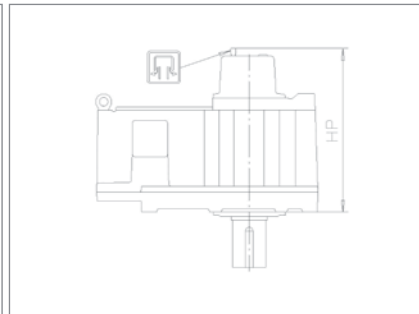

Expansion tank with bath lubrication

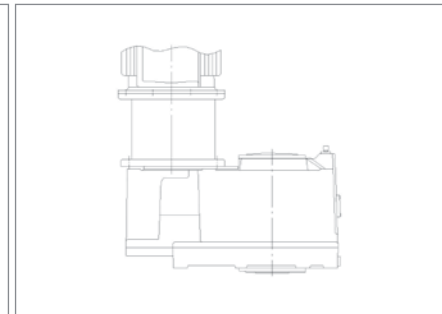

Motor flange, page 12.32

Size	LSS dimensions in mm														Common accessories
	Solid shaft							Hollow shaft							
	d2	b2	h2	m2	Y2	U2	V2	U5	V5	U3	UC	D4	D5	HP	
60	160m6	40h9	169	M30	270	35	305	674	944	35	796	180	179	984	
70	180m6	45h9	190	M30	270	35	305	725	995	35	863	190	189	1084	
80	200m6	45h9	210	+))	315	35	350	785	1100	35	928	210	209	1275	

+) M20,2x180°, distance 0.6xd2

Other available accessories, see section 12

Lubrication	Page
Lubrication unit	12.23
Oil heating system 3)	12.27
Expansion tank for moist environment	12.29
Optional seal arrangements	12.30
Lip seal on HSS and LSS	2)

Coupled equipment	Page
Couplings	*)
Belt drive	12.32

See also modifications, page 12.35-12.37

2) Standard solution for this gear unit type
*) Contact Santasalo

3-stage helical gear units, vertical LSS

Gear unit dimensions, type D3PVSF, D3PVHF

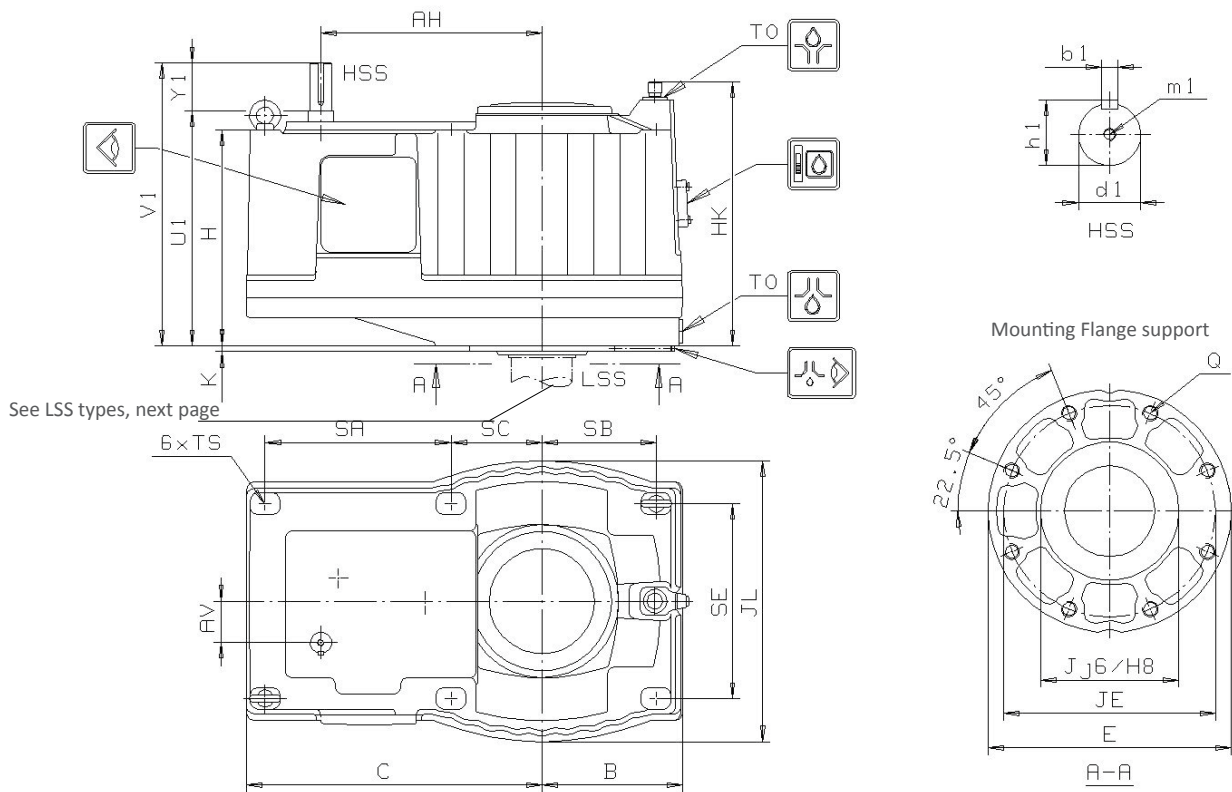

Size	Housing dimensions in mm																	
	AH	AV	B	C	E	H	HK	J	JE	JL	K	Q	SA	SB	SC	SE	TS	TO
10	281	56.9	195	402	315	314	451	200	275	390	10	M20x35	234	155	128	260	M16x32	1
20	303	46.0	210	414	348	328	474	215	300	420	10	M24x42	236	170	138	280	M16x32	1
30	381	71.0	242	522	400	393	548	270	340	484	12	M30x53	321	192	171	310	M20x35	1
40	422	62.7	275	566	460	431	589	280	400	550	12	M30x53	342	225	193	364	M20x35	1
50	511	95.7	325	682	562	499	634	320	490	650	12	M36x63	431	270	215	440	M24x42	1½

Size	HSS dimensions in mm							Weight	Oil Capacity	
	$i_n = 20...90$								kg	Bath lubrication
	U1	Y1	V1	d1	b1	h1	m1	l		l
10	344	70	414	35k6	10h9	38	M12	240	33	13
20	358	70	428	35k6	10h9	38	M12	290	38	15
30	426	95	521	40k6	12h9	43	M16	430	66	24
40	470	95	565	40k6	12h9	43	M16	660	92	33
50	539	95	634	45k6	14h9	48,5	M16	1010	150	50

Shaft positions

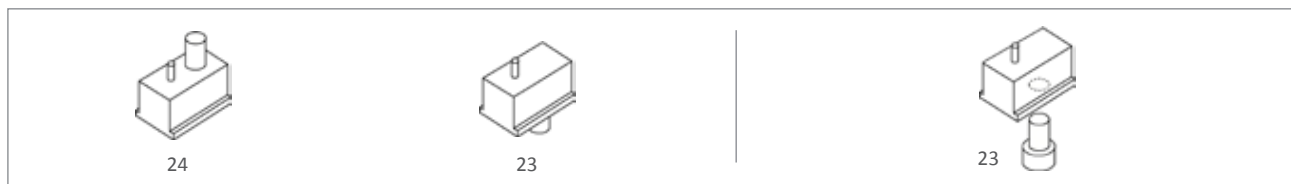

3-stage helical gear units, vertical LSS

LSS types

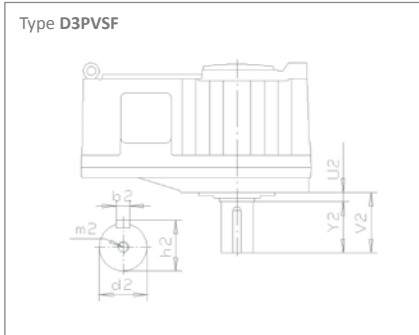

Solid shaft downwards

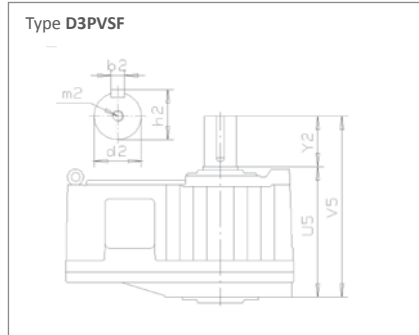

Solid shaft upwards

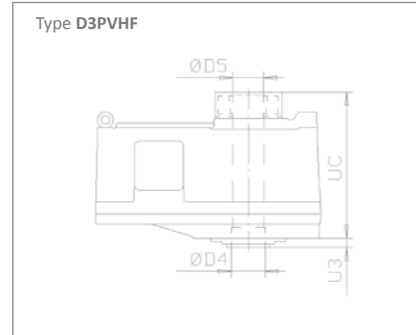

Hollow shaft, shrink disk, page 12.13

Common accessories, see section 12

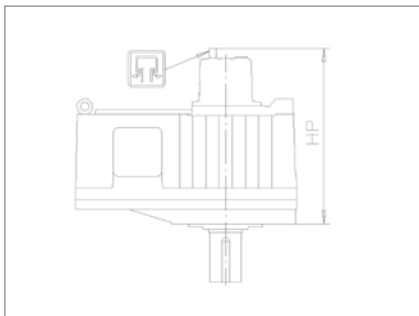

Expansion tank, with bath lubrication

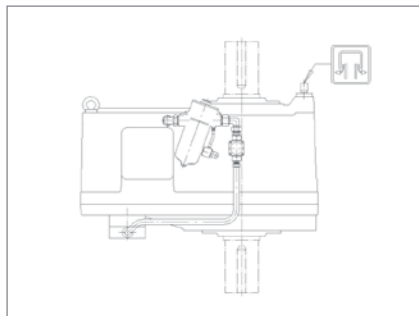

Shaft end pump, page 12.24,
with Pressure Lubrication

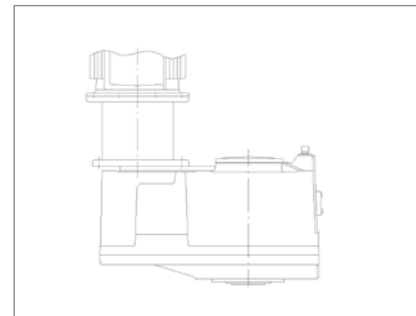

Motor flange, page 12.32

Size	Housing dimensions in mm										Hollow shaft			Common accessories
	Solid shaft										UC	D4	D5	HP
d2	b2	h2	m2	Y2	U2	V2	U5	V5	U3					
10	85m6	22h9	90	M20	150	25	175	394	544	25	445	85	84	547
20	90m6	25h9	95	M24	150	25	175	415	565	25	470	95	94	570
30	110m6	28h9	116	M24	190	25	215	493	683	25	555	120	119	648
40	120m6	32h9	127	M24	190	25	215	534	724	25	600	130	129	725
50	140m6	36h9	148	M30	225	25	250	597	822	25	700	155	154	825

Other available accessories, see section 12

Accessories	Page
Mounting flange	12.17
Lubrication	Page
Lubrication unit	12.23
Oil heating system 3)	12.27
Oil drain valves	12.28
Expansion tank for moist environment	12.29

Optional seal arrangements	12.30
Lip seal on HSS and LSS	2)
Coupled equipment	Page
Couplings	*)
Belt drive	12.32

2) Standard solution for this gear unit type
3) For gear unit size 50
*) Contact Santasalo

See also modifications, page 12.35-12.37

3-stage helical gear units, vertical LSS

Gear unit dimensions, type D3PVSF D3PVHF

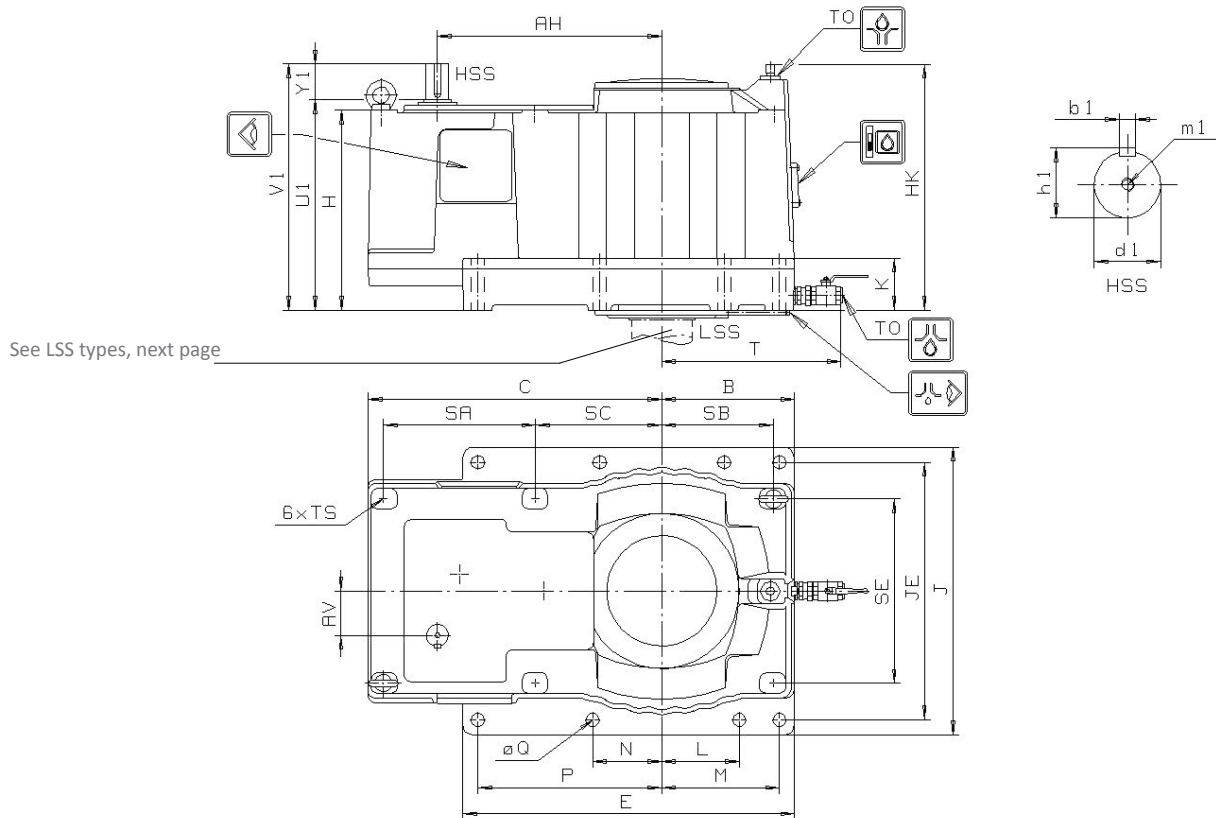

Size	Housing dimensions in mm																					
	AH	AV	B	C	E	H	HK	J	JE	K	L	M	N	P	Q	SA	SB	SC	SE	TS	TO	T
60	606	68,8	405	778	810	570	711	810	700	165	-	350	-	350	48	397	343	343	486	M24x42	1½	572
70	694	119,7	405	906	1010	620	771	920	810	171	-	350	235	550	48	480	343	388	576	M24x42	1½	572
80	745	121,7	440	959	1100	662	823	1000	890	182	235	385	235	605	48	481	367	427	608	M30x53	1½	607
90	811	160,2	480	1061	1200	722	893	1040	930	188	235	425	235	665	48	550	407	459	654	M30x53	1½	647

Size	HSS dimensions in mm							Weight	Oil Capacity	
	$i_n = 20 \dots 90$								kg	Bath lubrication
	U1	Y1	V1	d1	b1	h1	m1	l		l
60	610	95	705	50k6	14h9	53.5	M16	1450	180	60
70	660	125	785	60m6	18h9	64	M20	1050	260	85
80	702	125	827	65m6	18h9	69	M20	2540	350	120
90	762	125	887	75m6	20h9	79.5	M20	3230	450	150

Shaft positions

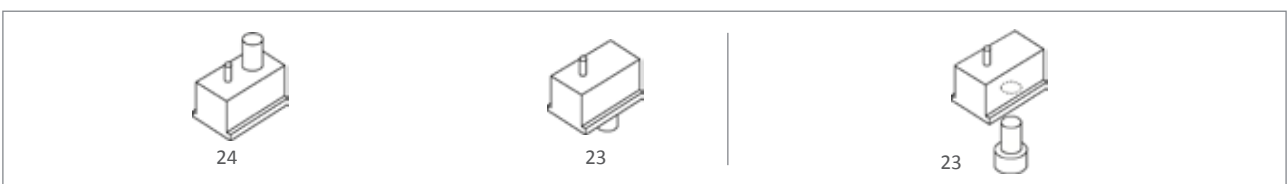

3-stage helical gear units, vertical LSS

LSS types

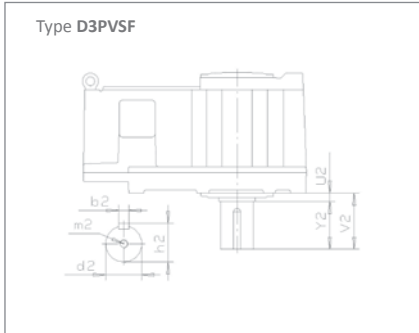

Solid shaft downwards

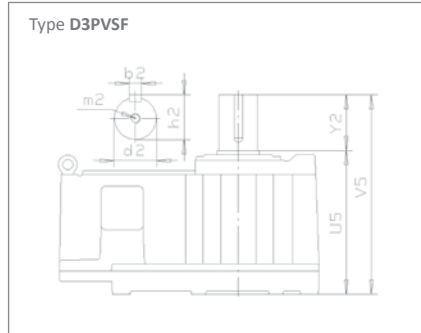

Solid shaft upwards

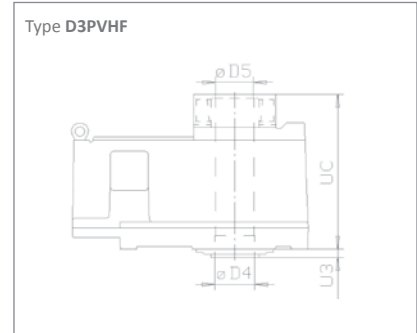

Hollow shaft, shrink disk, page 12.13

Common accessories, see section 12

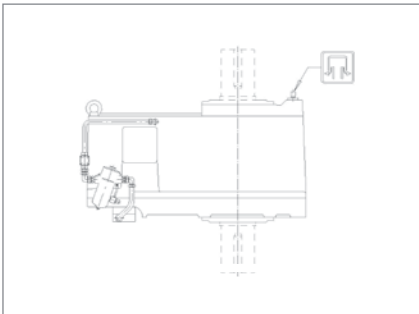

Shaft end pump,
page 12.24, with pressure lubrication

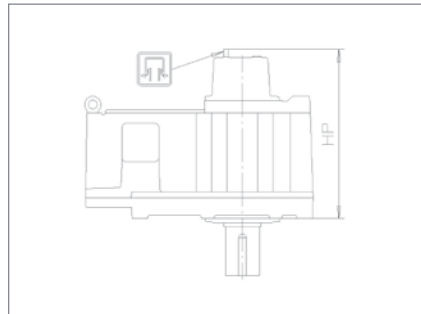

Expansion tank with bath lubrication

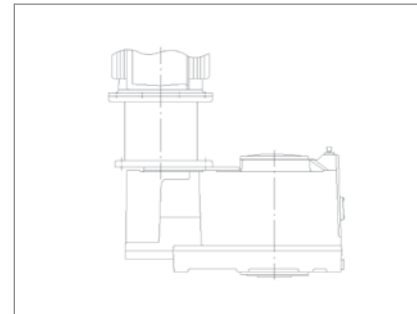

Motor flange, Page 12.32

Size	LSS dimensions in mm										Hollow Shaft		Common accessories	
	Solid shaft										U3	UC	D4	D5
	d2	b2	h2	m2	Y2	U2	V2	U5	V5					
60	160m6	40h9	169	M30	270	35	305	674	944	35	796	180	179	984
70	180m6	45h9	190	M30	270	35	305	725	995	35	863	190	189	1084
80	200m6	45h9	210	+)	315	35	350	785	1100	35	928	210	209	1275
90	220m6	50h9	231	+)	315	35	350	855	1170	35	1024	250	249	1350

+) M20,2x180°, distance

Other available accessories, see section 12

Lubrication	Page
Lubrication Unit	12.23
Oil Heating System	12.27
Expansion tank for moist environment	12.29

Optional seal arrangements	12.30
Lip seal on HSS and LSS	2)

Coupled equipment	Page
Couplings	*)
Belt drive	12.32

See also modifications, page 12.35-12.37

2) Standard solution for this gear unit type
*) Contact Santasalo

3-stage helical gear units, vertical LSS

Gear unit dimensions, type D3PVSF

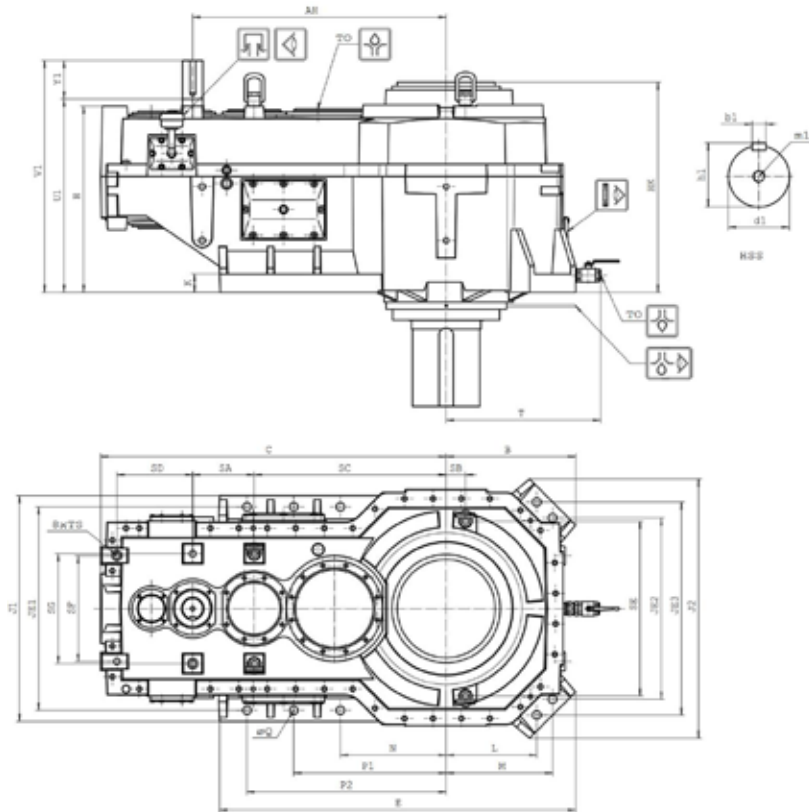

Size	Housing Dimensions in mm													
	AH	B	C	E	H	HK	J1	J2	JE1	JE2	JE3	K	L	M
100	1123	600	1563	1613	804	946	1040	1200	940	800	1012	84	400	506
110	1247	636	1700	1751	915	1033	1110	1273	1000	891	1047	90	446	523
120	1388	712	1871	1952	985	1045	1240	1425	1140	990	1174	90	495	587

Size	Housing Dimensions in mm														
	N	P1	P2	Q	SA	SB	SC	SD	SE	SF	SG	TS	TO	T	
100	520	750	960	42	271	95	854	370	790	450	470	M30x53	R1½	670	
110	520	750	980	42	303	95	944	373	859	520	540	M30x53	R1½	760	
120	580	840	1100	42	333	129	1055	388	966	610	660	M30x53	R1½	815	

Size	HSS dimensions in mm								Weight	Oil Capacity	
	$i_n = 20 \dots 90$									kg	Bath lubrication
	U1	Y1	V1	d1	b1	h1	m1		l		l
100	869	150	1019	95m6	25h9	100	M24	5500	625	180	
110	950	190	1140	100m6	28h9	106	M24	8100	695	155	
120	1050	190	1240	110m6	28h9	116	M24	10150	775	215	

Shaft positions

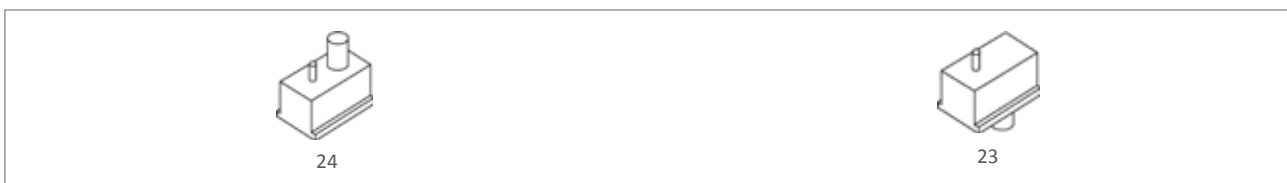

3-stage helical gear units, vertical LSS

LSS types

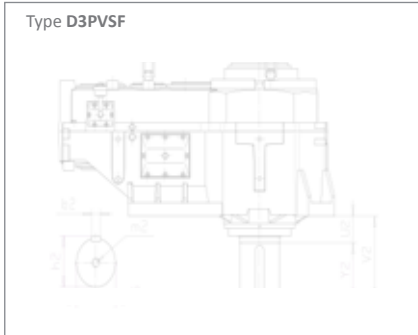

Solid shaft downwards

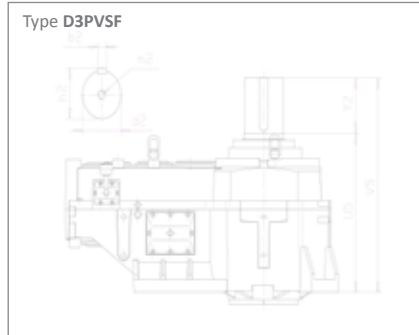

Solid shaft upwards

Common accessories, see section 12

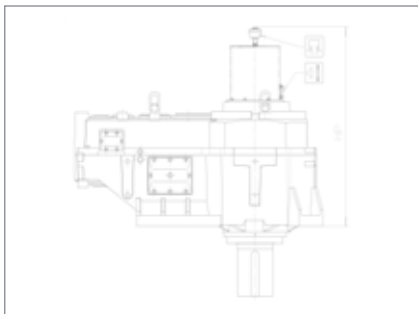

Expansion tank with bath lubrication

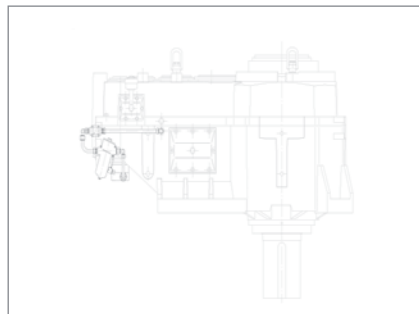

Shaft end pump, with pressure lubrication

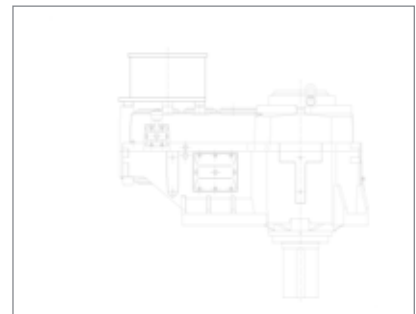

Motor flange, page 12.32

Size	LSS dimensions in mm									Common accessories
	d2	b2	h2	m2 ¹⁾	Y2	U2	V2	U5	V5	HP
100	310m6	70h9	324	M24	380	130	510	983	1363	1496
110	330m6	70h9	344	M30	380	180	560	1140	1520	1597
120	350m6	80h9	365	M30	450	230	680	1171	1621	1682

1) 2 x 180° distance 0,6 x d1

Other available accessories, see section 12

Lubrication	Page
Lubrication Unit	12.23
Oil heating System	12.27
Expansion tank for moist environment	12.29

Optional Seal Arrangements	12.30
Lip Seal on HSS and LSS	2)

2) Standard solution for this gear unit type
*) Contact Santasalo

Coupled equipment	Page
Couplings	*)
Belt Drive	12.32

See also modifications, page 12.35-12.37

4-stage helical gear units, vertical LSS

Gear unit dimensions, type D4PVSF D4PVHF

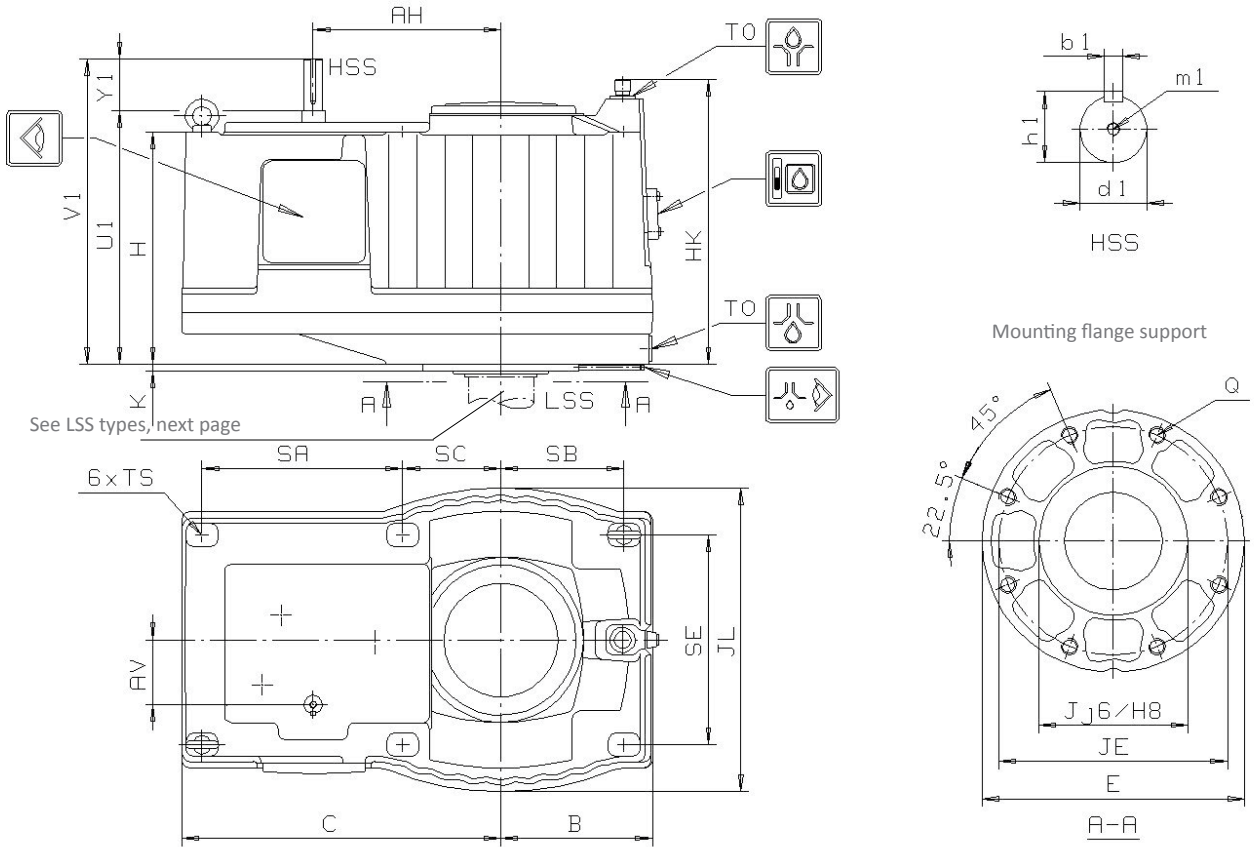

Size	Housing Dimensions in mm																	
	AH	AV	B	C	E	H	HK	J	JE	JL	K	Q	SA	SB	SC	SE	TS	TO
50	406	147.4	325	682	562	499	634	320	490	650	12	M36x63	431	270	215	440	M24x42	1½

Size	HSS dimensions in mm								Weight	Oil Capacity	
	$i_n = 100 \dots 400$									Bath lubrication	Pressure lubrication
	U1	Y1	V1	d1	b1	h1	m1	kg	l	l	
50	539	70	609	35k6	10h9	38	M12	1030	148	49	

Shaft positions



4-stage helical gear units, vertical LSS

LSS types

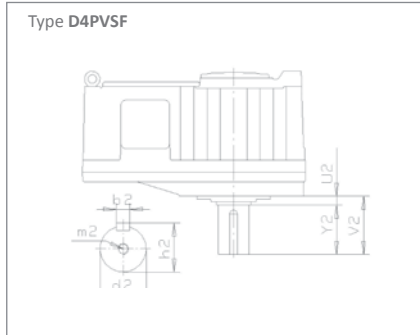

Solid shaft downwards

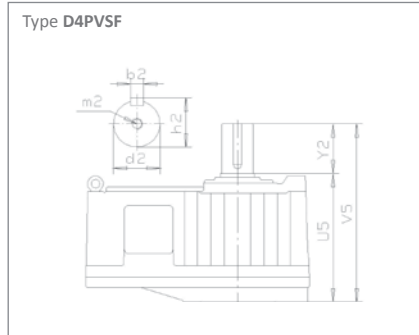

Solid shaft upwards

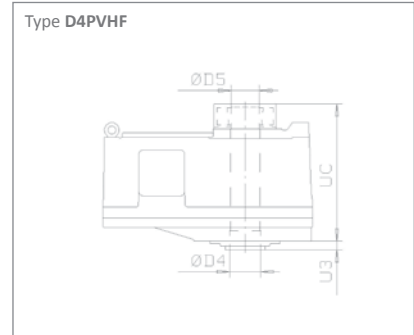

Hollow shaft, shrink disk, page 12.13

Common accessories, see section 12

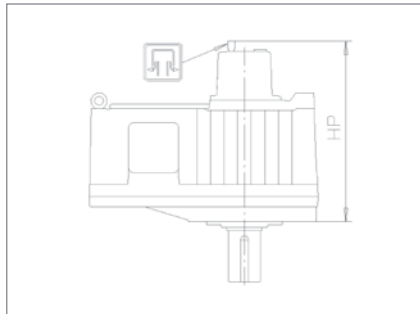

Expansion tank with bath lubrication

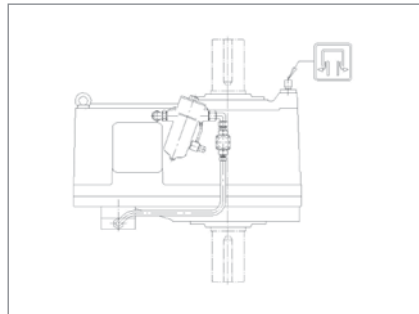

Shaft end pump, page 12.24,
with pressure lubrication

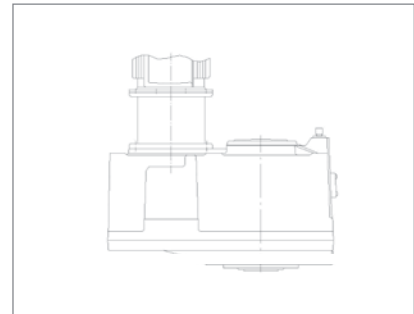

Motor flange, page 12.32

Size	LSS dimensions in mm													Common accessories	
	Solid shaft													HP	
	d2	b2	h2	m2	Y2	U2	V2	U5	V5	U3	UC	D4	D5	HP	
50	140m6	36h9	148	M30	225	25	250	597	822	25	700	155	154	825	

Other available accessories, see section 12

Accessories	Page
Mounting flange	12.17
Lubrication Unit	12.23
Oil heating System	12.27
Oil drain Valves	12.28
Expansion tank for moist environment	12.29

Optional Seal Arrangements	12.30
Lip Seal on HSS and LSS	2)
Coupled equipment	Page
Couplings	*)
Belt Drive	12.32

2) Standard solution for this gear unit type
*) Contact Santasalo

See also modifications, page 12.35-12.37

4-stage helical gear units, vertical LSS

Gear unit dimensions, type D4PVSF D4PVHF

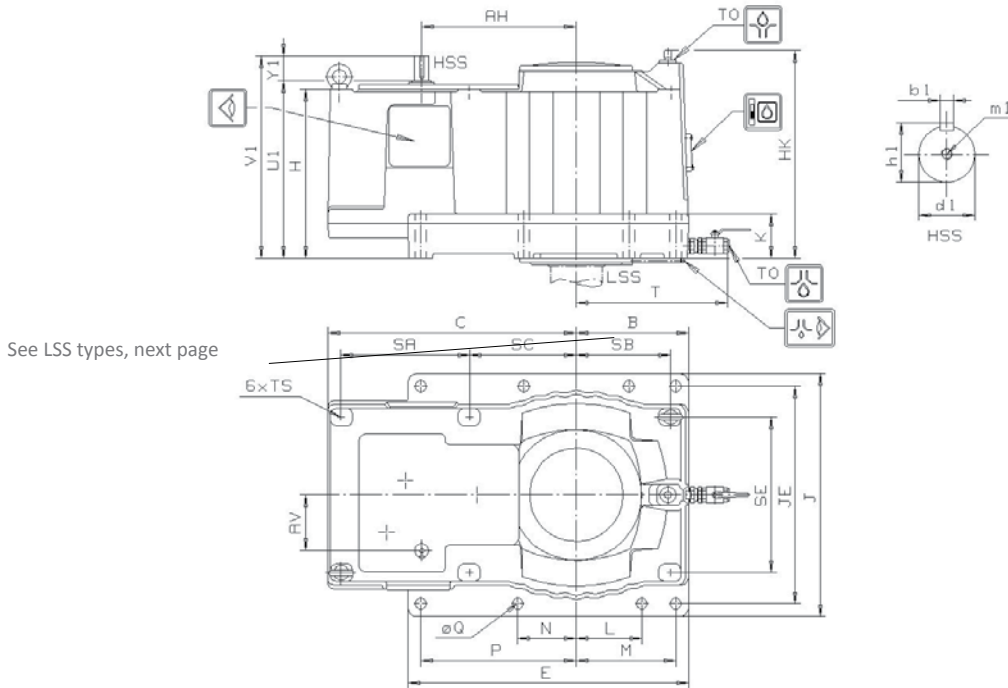

Size	Housing Dimensions in mm																					
	AH	AV	B	C	E	H	HK	J	JE	K	L	M	N	P	Q	SA	SB	SC	SE	TS	TO	T
60	526	154.2	405	778	810	570	711	810	700	165	-	350	-	350	48	397	343	343	486	M24x42	1½	572
70	569	209.7	405	906	1010	620	771	920	810	171	-	350	235	550	48	480	343	388	576	M24x42	1½	572
80	625	218.2	440	959	1100	662	823	1000	890	182	235	385	235	605	48	481	367	427	608	M30x53	1½	607
90	670	253.3	480	1061	1200	722	893	1040	930	188	235	425	235	665	48	550	407	459	654	M30x53	1½	647

Size	HSS dimensions in mm								Weight	Oil capacity	
	$i_N = 100 \dots 400$									kg	Bath lubrication
	U1	Y1	V1	d1	b1	h1	m1		l		l
60	610	70	680	35k6	10h9	38	M12	1470	177	59	
70	660	95	755	45k6	14h9	48.5	M16	2090	257	84	
80	702	95	797	45k6	14h9	48.5	M16	2590	347	118	
90	762	95	857	55m6	16h9	59	M20	3290	446	148	

Shaft positions

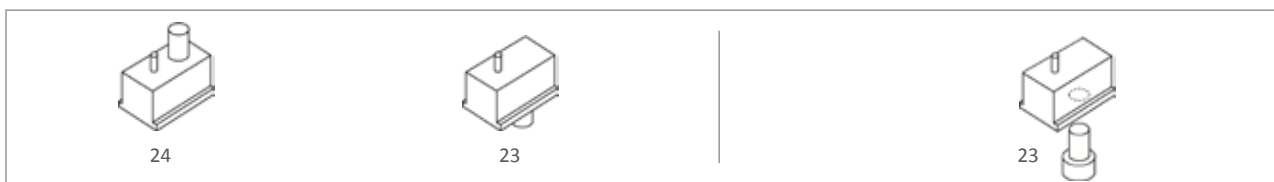

4-stage helical gear units, vertical LSS

LSS types

Type D4PVSF

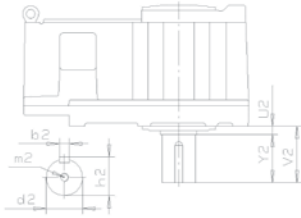

Solid shaft downwards

Type D4PVSF

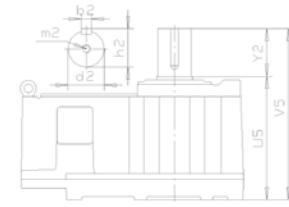

Solid shaft upwards

Type D4PVHF

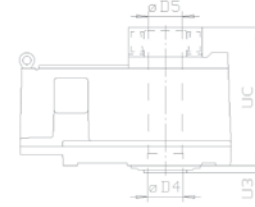

Hollow shaft, shrink disk, page 12.13

Common accessories, see section 12

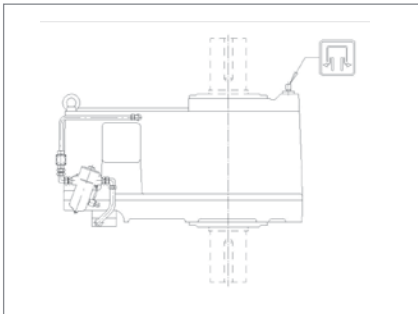

Shaft end pump, page 12.24, with pressure lubrication

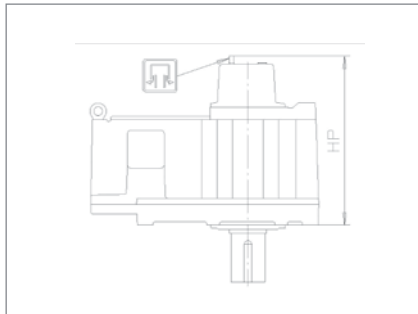

Expansion tank with bath lubrication

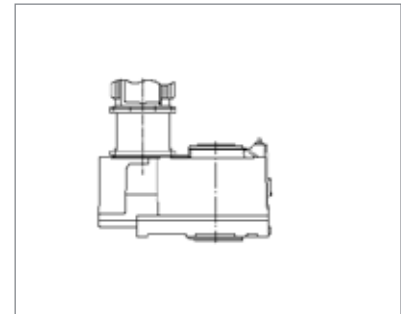

Motor flange, page 12.32

Size	LSS dimensions in mm													Common accessories
	Solid shaft											Common accessories		
	d2	b2	h2	m2	Y2	U2	V2	U5	V5	U3	UC	D4	D5	HP
60N	160m6	40h9	169	M30	270	35	305	674	944	35	796	180	179	984
70N	180m6	45h9	190	M30	270	35	305	725	995	35	863	190	189	1084
80N	200m6	45h9	210	+)	315	35	350	785	1100	35	928	210	209	1275
90N	220m6	50h9	231	+)	315	35	350	855	1170	35	1024	250	249	1350

+) M20,2x180°, distance

Other available accessories, see section 12

Lubrication	Page
Lubrication Unit	12.23
Oil Heating System	12.27
Expansion tank for moist environment	12.29

Coupled equipment	Page
Couplings	*)
Belt Drive	12.32

See also modifications, page 12.35-12.37

2) Standard solution for this gear unit type
*) Contact Santasalo

Optional Seal Arrangements	12.30
Lip Seal on HSS and LSS	2)

4-stage helical gear units, vertical LSS

Gear unit dimensions, type D4PVSF

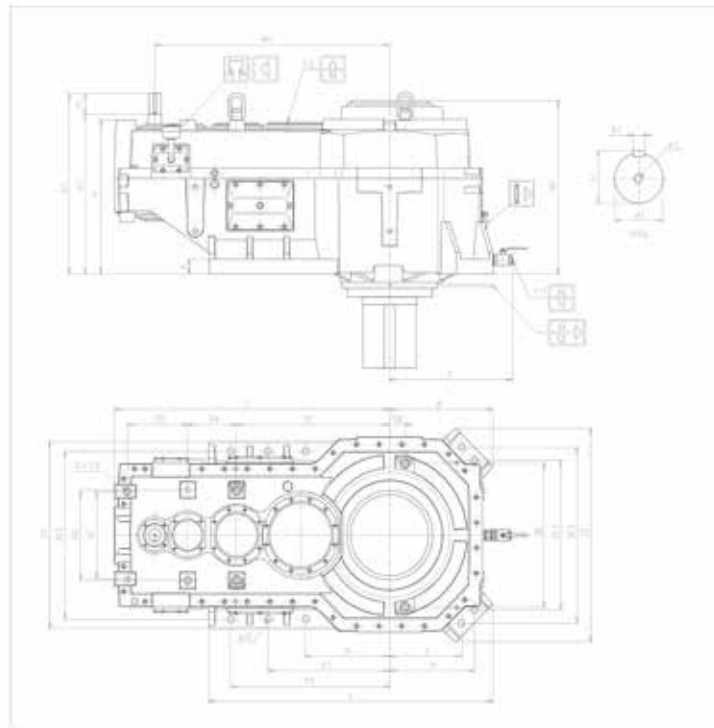

Size	Housing Dimensions in mm													
	AH	B	C	E	H	HK	J1	J2	JE1	JE2	JE3	K	L	M
100	1313	600	1563	1613	804	946	1040	1200	940	800	1012	84	400	506
110	1450	636	1700	1751	915	1033	1110	1273	1000	891	1047	90	446	523
120	1606	712	1871	1952	985	1045	1240	1425	1140	990	1174	90	495	587

Size	Housing Dimensions in mm														
	N	P1	P2	Q	SA	SB	SC	SD	SE	SF	SG	TS	TO	T	
100	520	750	960	42	271	95	854	370	790	450	470	M30x53	R1½	670	
110	520	750	980	42	303	95	944	373	859	520	540	M30x53	R1½	760	
120	580	840	1100	42	333	129	1055	388	966	610	660	M30x53	R1½	815	

Size	HSS dimensions in mm								Weight	Oil Capacity	
	$i_n = 100 \dots 400$									kg	Bath lubrication
	U1	Y1	V1	d1	b1	h1	m1	l	l		
100	869	125	994	70m6	20h9	74.5	M20	5500	625	180	
110	950	125	1075	75m6	20h9	79.5	M20	8100	695	155	
120	1050	150	1200	80m6	22h9	85	M20	10150	775	215	

Shaft positions

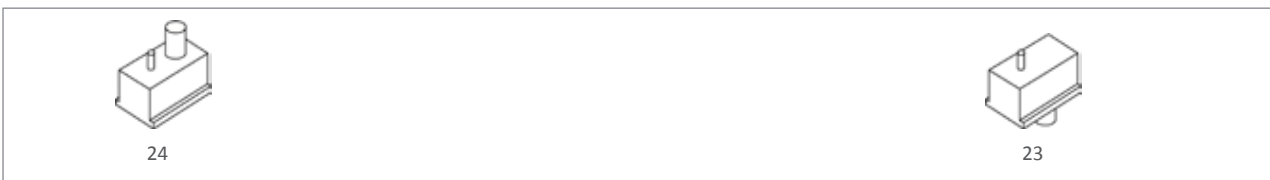

4-stage helical gear units, vertical LSS

LSS types

Type D4PVSF

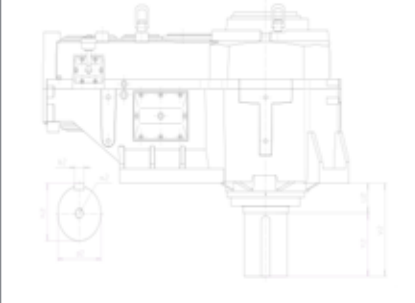

Solid shaft downwards

Type D4PVSF

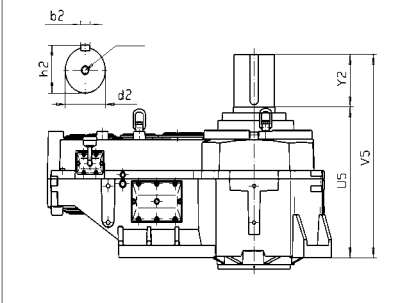

Solid shaft upwards

Common accessories, see section 12

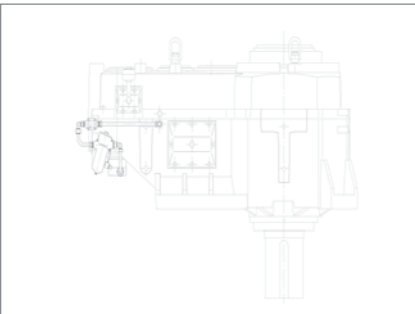

Shaft end pump, with pressure lubrication

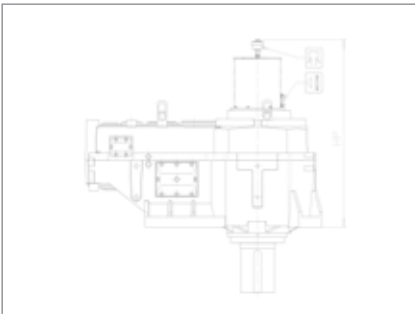

Expansion tank with bath lubrication

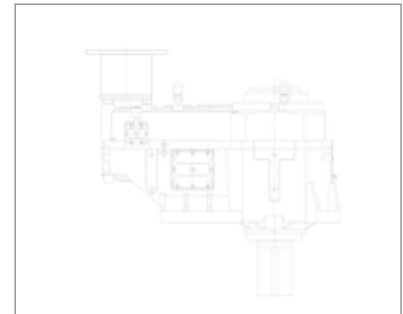

Motor flange, page 12.32

Size	LSS dimensions in mm									Common accessories
	Solid shaft									HP
	d2	b2	h2	m2 ¹⁾	Y2	U2	V2	U5	V5	
100	310m6	70h9	324	M24	380	130	510	983	1363	1496
110	330m6	70h9	344	M30	380	180	560	1140	1520	1597
120	350m6	80h9	365	M30	450	230	680	1171	1621	1682

1) 2 x 180° distance 0,6 x d1

Other available accessories, see section 12

Lubrication	Page	Coupled equipment	Page
Lubrication Unit	12.23	Couplings	*)
Oil Heating System	12.27	Belt Drive	12.32
Expansion tank for moist environment	12.29		
Optional Seal Arrangements	12.30		
Lip Seal on HSS and LSS	2)		

See also modifications, page 12.35-12.37

2) Standard solution for this gear unit type
*) Contact Santasalo

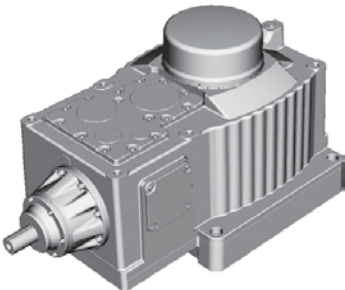
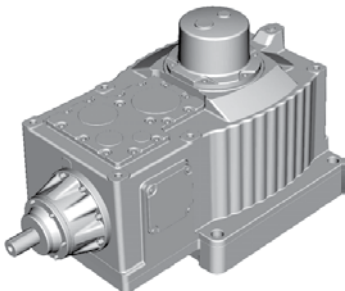

3-stage bevel-helical gear units, vertical LSS

Gear unit dimensions, type D3RVSF D3RVHF

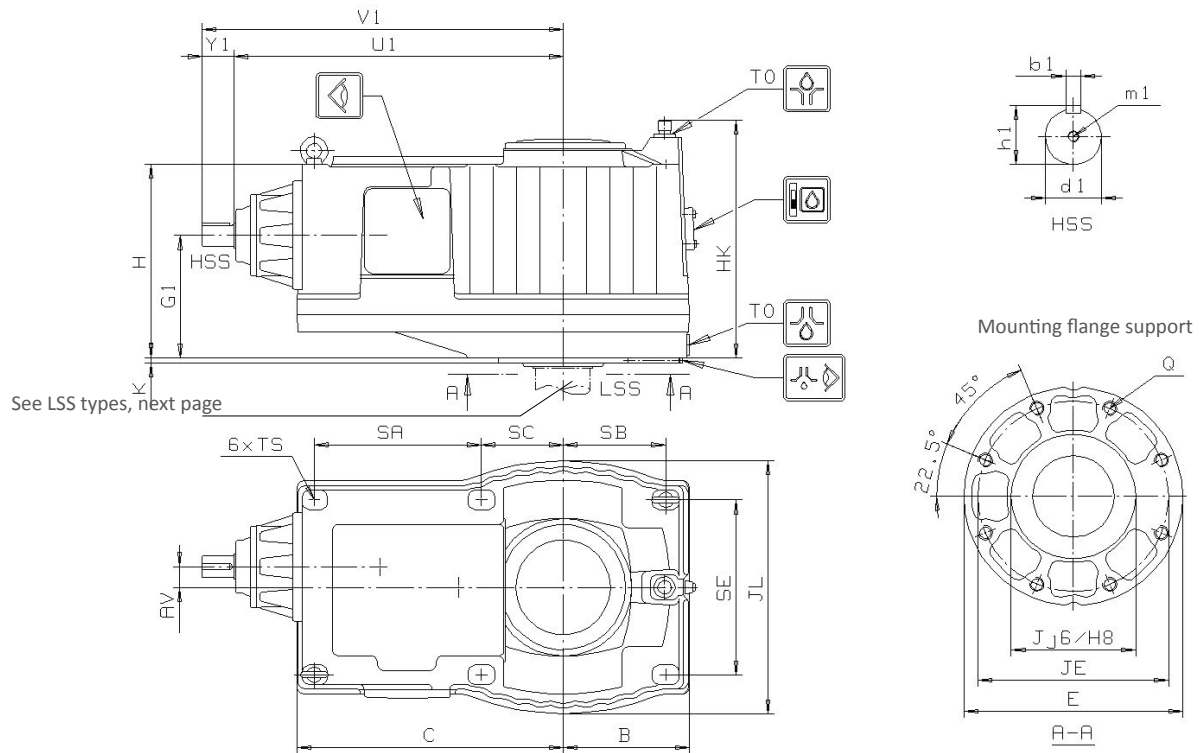

Size	Housing dimensions in mm																	
	AV	B	C	E	G1	H	HK	J	JE	JL	K	Q	SA	SB	SC	SE	TS	TO
30	42.6	242	522	400	252	393	548	270	340	484	12	M30x53	321	192	171	310	M20x35	1
40	51.4	275	566	460	275	431	589	280	400	550	12	M30x53	342	225	193	364	M20x35	1
50	53.0	325	682	562	314	499	634	320	490	650	12	M36x63	431	270	215	440	M24x42	1½

Size	HSS dimensions in mm												Weight kg	Oil capacity		
	$i_N=14...63$						$i_N=71...80$							Bath lubrication	Pressure lubrication	
	U1	Y1	V1	d1	b1	h1	m1	Y1	V1	d1	b1	h1		m1	l	l
30	683	95	778	45k6	14h9	48.5	M16	70	753	35k6	10h9	38	M12	460	66	24
40	726	95	821	45k6	14h9	48.5	M16	95	821	45k6	14h9	48.5	M16	700	92	33
50	$i_N=14...56$						$i_N=63...80$						1040	150	50	
	878	95	973	55m6	16h9	59	M20	95	973	45k6	14h9	48.5				M16

Shaft positions

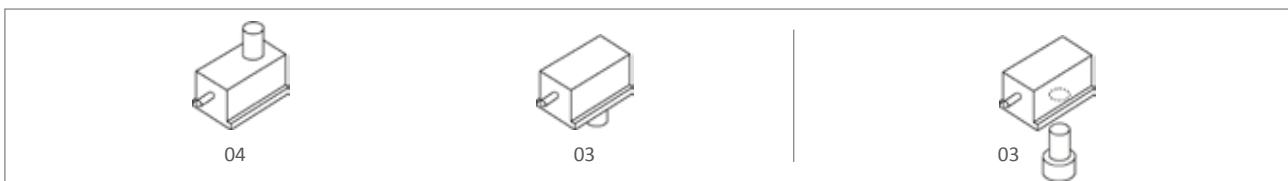

3-stage bevel-helical gear units, vertical LSS

LSS types

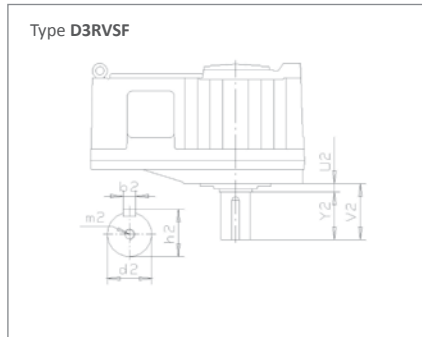

Solid shaft downwards

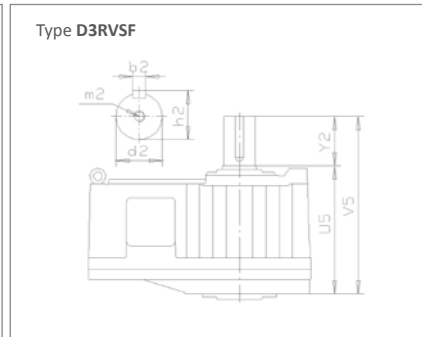

Solid shaft upwards

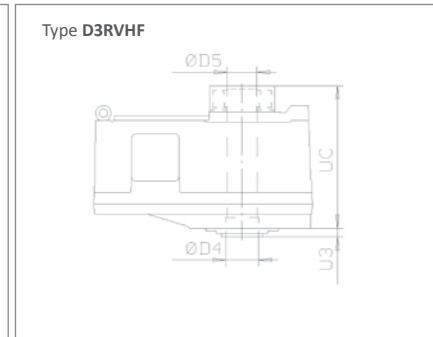

Hollow shaft, shrink disk, page 12.13

Common accessories, see section 12

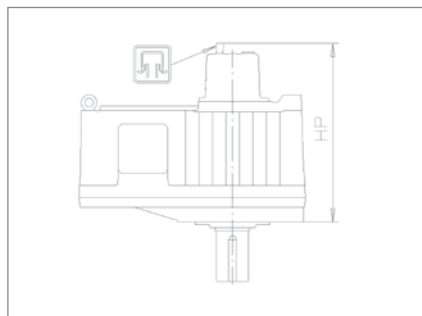

Expansion tank, with bath lubrication

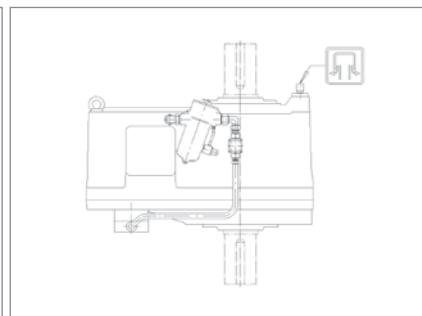

Shaft end pump, page 12.24,
 With pressure lubrication

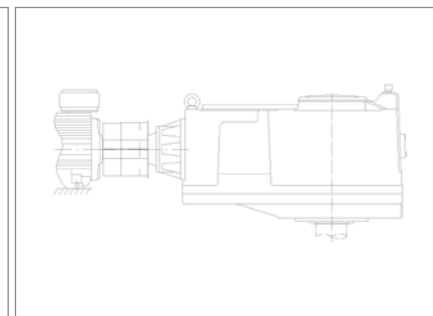

Coupling guard, page 12.31

Size	LSS dimensions in mm													Common accessories
	Solid shaft								Hollow shaft					HP
	d2	b2	h2	m2	Y2	U2	V2	U5	V5	U3	UC	D4	D5	
30	110m6	28h9	116	M24	190	25	215	493	683	25	555	120	119	648
40	120m6	32h9	127	M24	190	25	215	534	724	25	600	130	129	725
50	140m6	36h9	148	M30	225	25	250	597	822	25	700	155	154	825

Other available accessories, see section 12

Mounting flange	12.17
Cooling	Page
Fan	12.21
Lubrication	Page
Lubrication unit	12.23
Oil heating system 3)	12.27
Oil drain valves	12.28
Expansion tank for moist environment	12.29

Optional seal arrangements	12.30
Lip seal on HSS and LSS	2)
Coupled equipment	Page
Couplings	*)
Belt drive	12.32

2) Standard solution for this gear unit type
 3) For gear unit size 50
 *) Contact Santasalo

See also modifications, page 12.35-12.37

3-stage bevel-helical gear units, vertical LSS

Gear unit dimensions, type D3RVSF D3RVHF

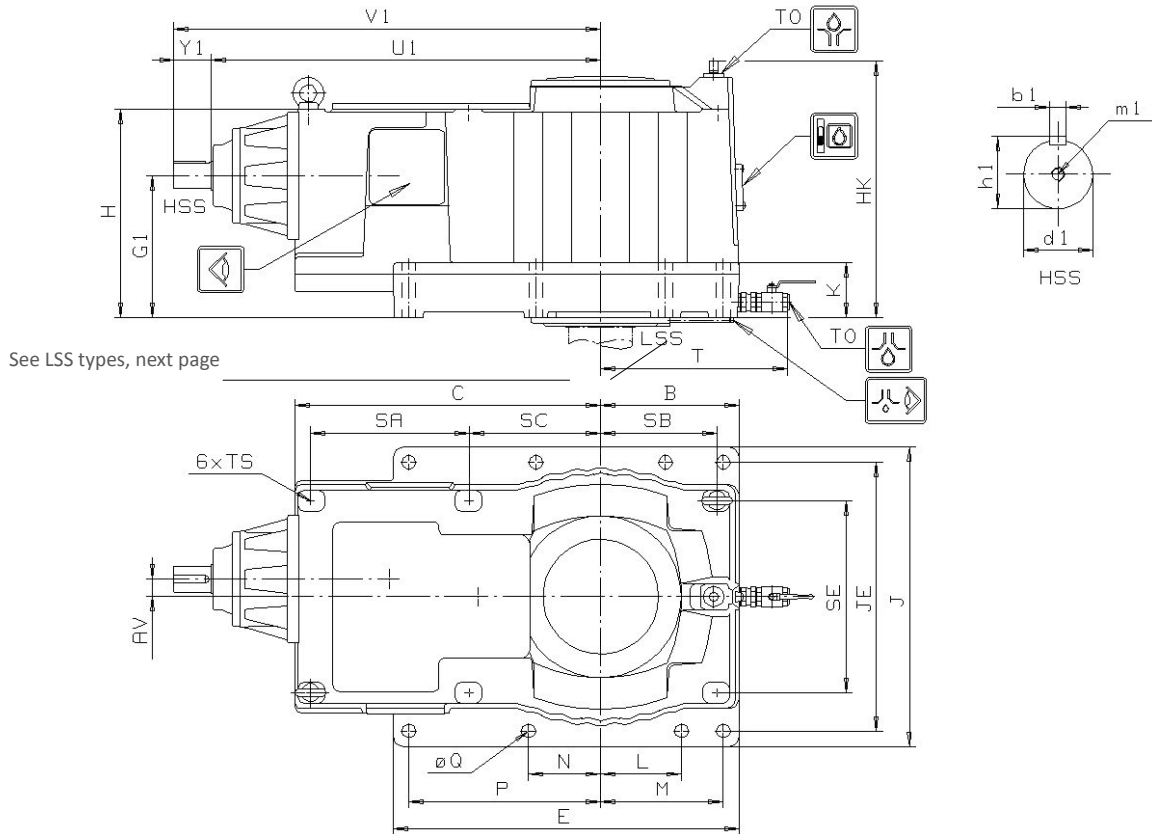

See LSS types, next page

Size	Housing dimensions in mm																					
	AV	B	C	E	G1	H	HK	J	JE	K	L	M	N	P	Q	SA	SB	SC	SE	TS	TO	T
60	82.6	405	778	810	362	570	711	810	700	165	-	350	-	350	48	397	343	343	486	M24x42	1½	572
70	69.0	405	906	1010	389	620	768	920	810	171	-	350	235	550	48	480	343	388	576	M24x42	1½	572
80	67.1	440	959	1100	413	662	823	1000	890	182	235	385	235	605	48	481	367	427	608	M30x53	1½	607
90	60.8	480	1061	1200	446	722	893	1040	930	188	235	425	235	665	48	550	407	459	654	M30x53	1½	647

Size	HSS dimensions in mm													Weight kg	Oil capacity	
	$i_N=14...56$						$i_N=63...80$						Bath lubrication		Pressure lubrication	
	U1	Y1	V1	d1	b1	h1	m1	Y1	V1	d1	b1	h1	m1		l	l
60	997	125	1122	65m6	18h9	69	M20	95	1092	55m6	16h9	59	M20	1530	180	60
70	1133	125	1258	75m6	20h9	79.5	M20	125	1258	60m6	18h9	64	M20	2160	260	85
	$i_N=14...63$						$i_N=71...80$									
80	1184	125	1309	75m6	20h9	79.5	M20	125	1309	60m6	18h9	64	M20	2680	350	120
90	1357	150	1507	90m6	25h9	95	M24	125	1482	70m6	20h9	74.5	M20	3440	450	150

Shaft positions

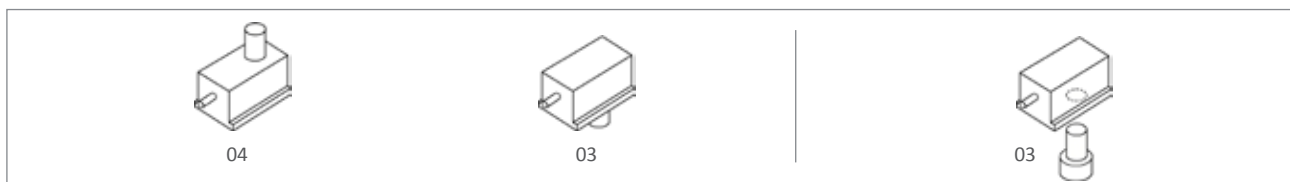

3-stage bevel-helical gear units, vertical LSS

LSS types

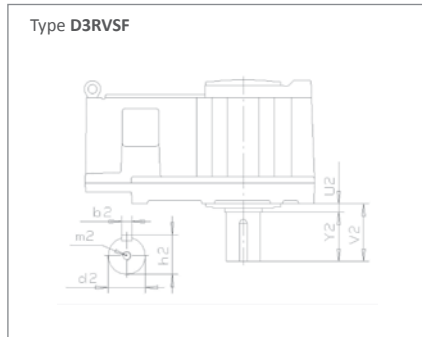

Solid shaft downwards

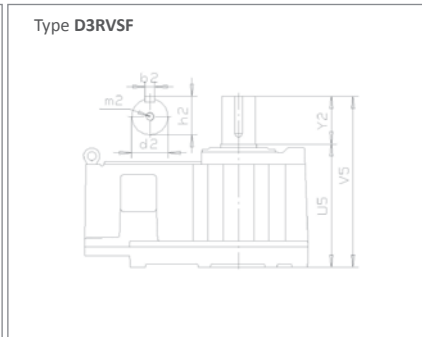

Solid shaft upwards

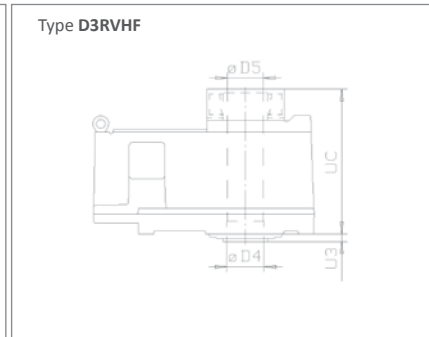

Hollow shaft, shrink disk, page 12.13

Common accessories, see section 12

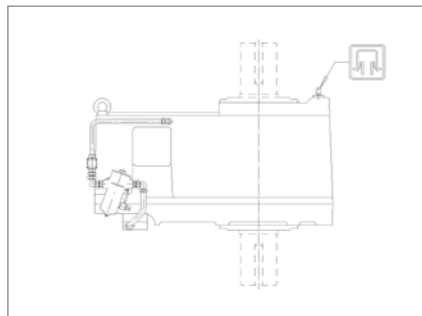

Shaft end pump, page 12.24
 With Pressure Lubrication

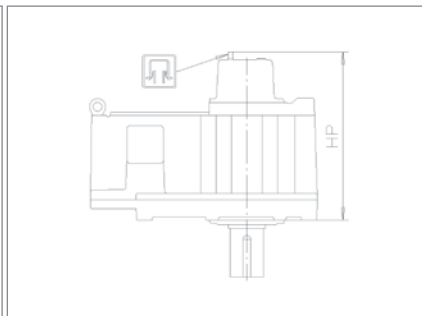

Expansion Tank, with Bath Lubrication

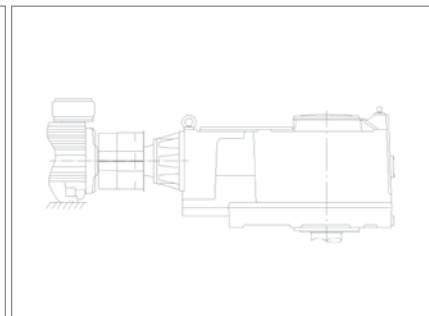

Coupling Guard, page 12.31

Size	LSS dimensions in mm													Common accessories
	Solid shaft						Hollow shaft							
	d2	b2	h2	m2	Y2	U2	V2	U5	V5	U3	UC	D4	D5	HP
60	160m6	40h9	169	M30	270	35	305	674	944	35	796	180	179	984
70	180m6	45h9	190	M30	270	35	305	725	995	35	863	190	189	1084
80	200m6	45h9	210	+))	315	35	350	785	1100	35	928	210	209	1275
90	220m6	50h9	231	+))	315	35	350	855	1170	35	1024	250	249	1350

+) M20,2x180°, distance 0.6xd2

Other available accessories, see section 1

Cooling	Page
Fan	12.21

Optional seal arrangements	12.30
Lip seal on HSS and LSS	2)

2) Standard solution for this gear unit type
 *) Contact Santasalo

Lubrication	Page
Lubrication unit	12.23
Oil heating system	3) 12.27
Expansion tank for moist environment	12.29

Coupled equipment	Page
Couplings	*)
Belt drive	12.32

See also modifications, page 12.35-12.37

4-stage bevel-helical gear units, vertical LSS

Gear unit dimensions, type D4RVSF D4RVHF

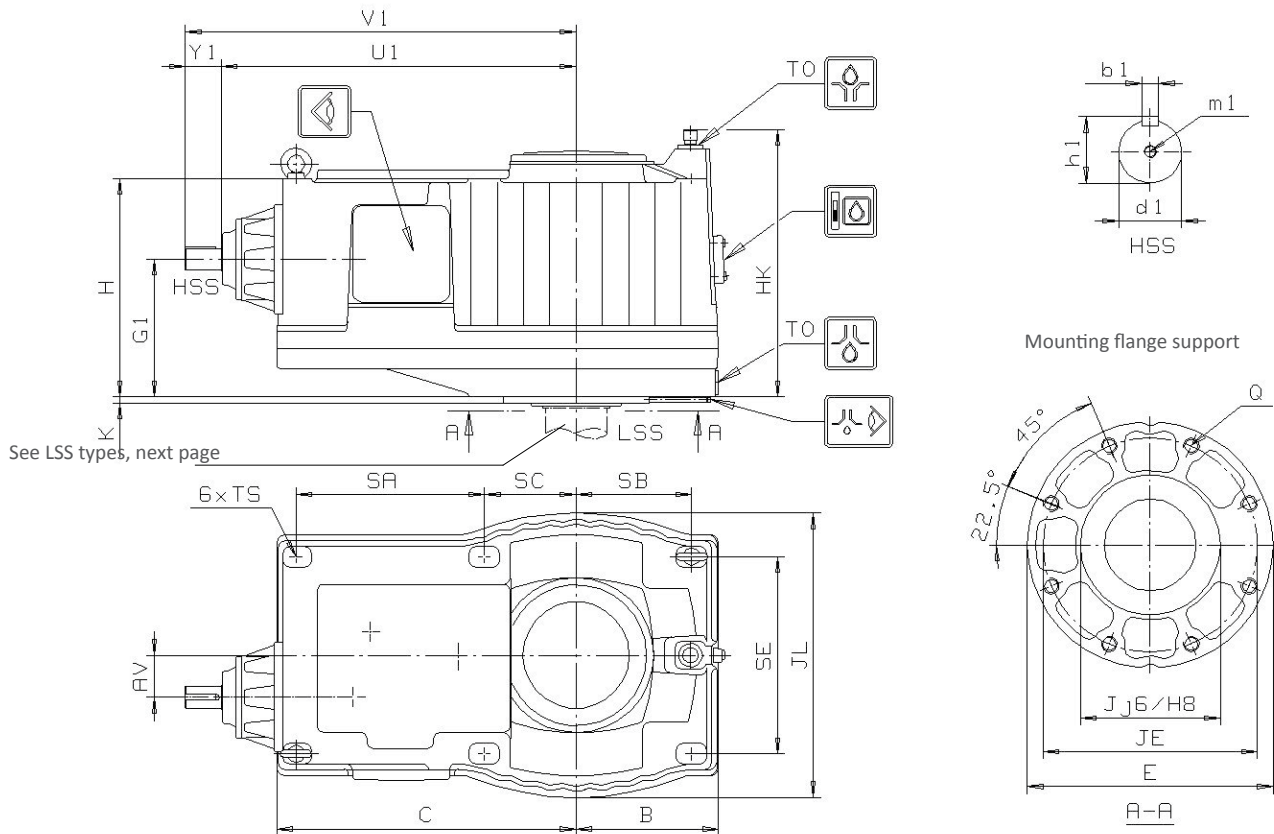

Size	Housing dimensions in mm																	
	AV	B	C	E	G1	H	HK	J	JE	JL	K	Q	SA	SB	SC	SE	TS	TO
50	95.7	325	682	562	314	499	634	320	490	650	12	M36x63	431	270	215	440	M24x42	1½

Size	HSS dimensions in mm												Weight	Oil capacity		
	$i_n=90...250$						$i_n=280...315$							Bath lubrication	Pressure lubrication	
	U1	Y1	V1	d1	b1	h1	m1	Y1	V1	d1	b1	h1		m1	l	l
50	841	95	936	45k6	14h9	48.5	M16	70	911	35k6	10h9	38	M12	1100	148	49

Shaft positions

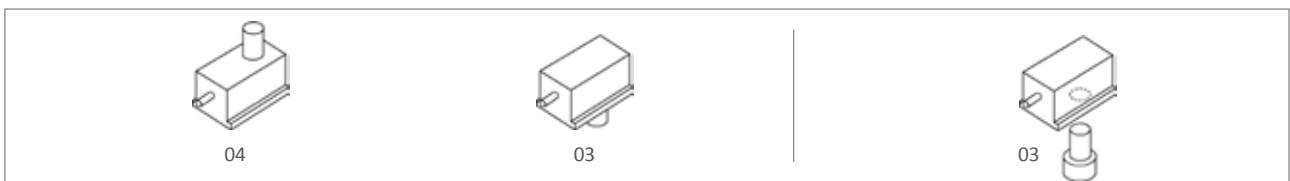

4-stage bevel-helical gear units, vertical LSS

LSS types

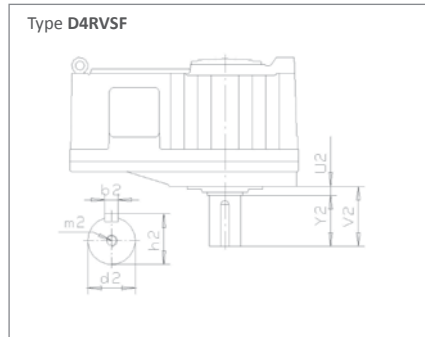

Solid shaft downwards

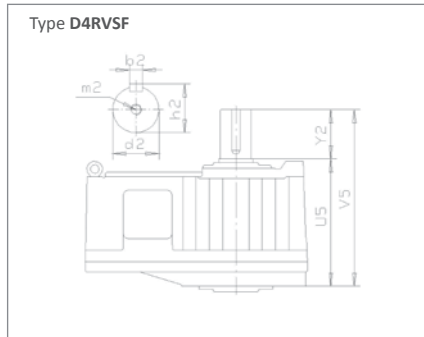

Solid shaft upwards

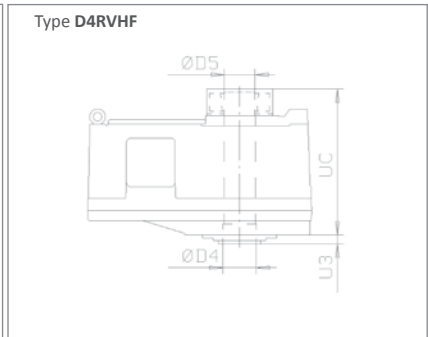

Hollow shaft, shrink disk, page 12.13

Common accessories, see section 12

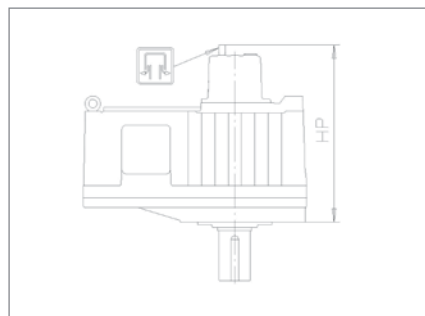

Expansion tank with bath lubrication

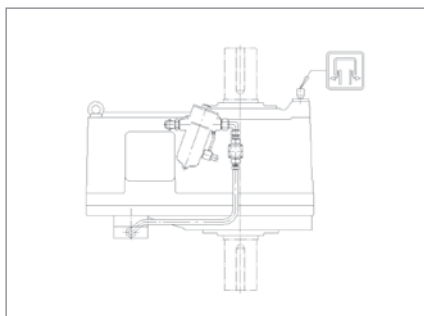

Shaft end pump, page 12.24 with pressure lubrication

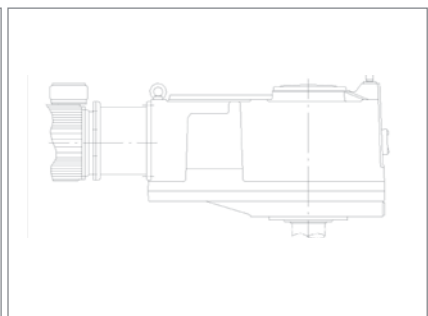

Motor flange, page 12.32

Size	LSS dimensions in mm												Common accessories	
	Solid shaft						Hollow shaft						HP	
	d2	b2	h2	m2	Y2	U2	V2	U5	V5	U3	UC	D4	D5	
50	140m6	36h9	148	M30	225	25	250	597	822	25	700	155	154	825

Other available accessories, see section 12

Lubrication	Page
Lubrication unit	12.23
Oil heating system	12.27
Oil drain valves	12.28
Expansion tank for moist environment	12.29

Coupled equipment	Page
Optional seal arrangements	12.30
Lip seal on HSS and LSS	2)
Couplings	*)
Coupling guard	12.31
Belt drive	12.32

2) Standard solution for this gear unit type
 *) Contact Santasalo

See also modifications, page 12.35-12.37

4-stage bevel-helical gear units, vertical LSS

Gear unit dimensions, type D4RVSF D4RVHF

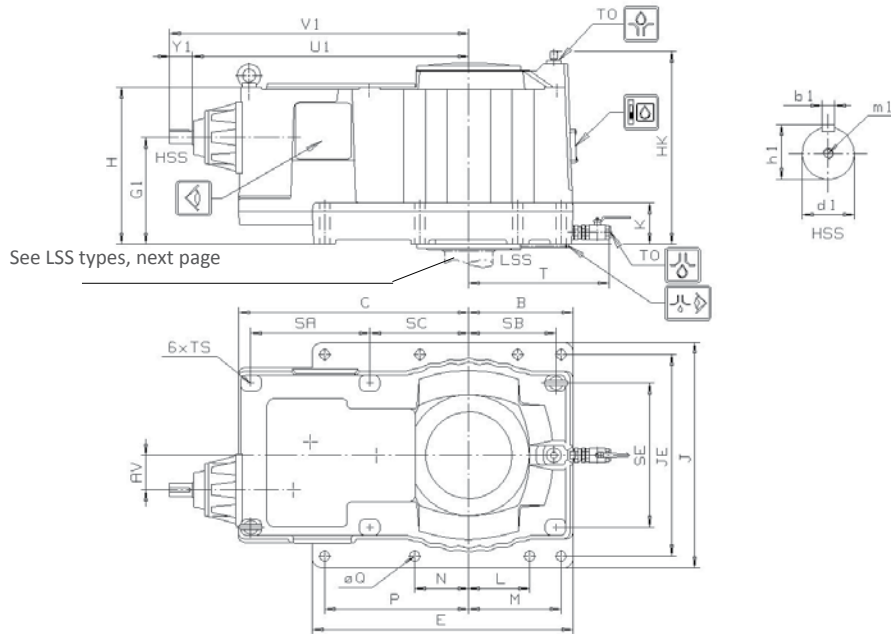

Size	Housing dimensions in mm																					
	AV	B	C	E	G1	H	HK	J	JE	K	L	M	N	P	Q	SA	SB	SC	SE	TS	TO	T
60	68.8	405	778	810	362	570	711	810	700	165	-	350	-	350	48	397	343	343	486	M24x42	1½	572
70	119.7	405	906	1010	389	620	771	920	810	171	-	350	235	550	48	480	343	388	576	M24x42	1½	572
80	121.7	440	959	1100	413	662	823	1000	890	182	235	385	235	605	48	481	367	427	608	M30x53	1½	607
90	160.2	480	1061	1200	446	722	893	1040	930	188	235	425	235	665	48	550	407	459	654	M30x53	1½	647

Size	HSS dimensions in mm													Weight kg	Oil capacity	
	$i_N=90...250$						$i_N=315...280$						Bath lubrication		Pressure lubrication	
	U1	Y1	V1	d1	b1	h1	m1	Y1	V1	d1	b1	h1	m1		l	l
60	936	95	1031	45k6	14h9	48.5	M16	70	1006	35k6	10h9	38	M12	1580	177	59
70	1101	95	1196	55m6	16h9	59	M20	95	1196	45k6	14h9	48.5	M16	2230	257	84
80	1152	95	1247	55m6	16h9	59	M20	95	1247	45k6	14h9	48.5	M16	2770	347	118
90	1277	125	1402	65m6	18h9	69	M20	95	1372	55m6	16h9	59	M20	3550	446	148

Shaft positions

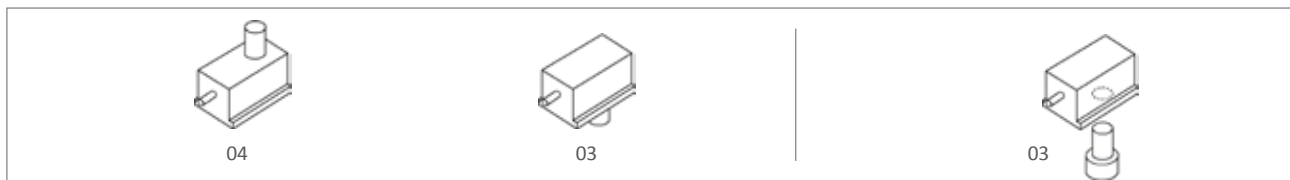

4-stage bevel-helical gear units, vertical LSS

LSS types

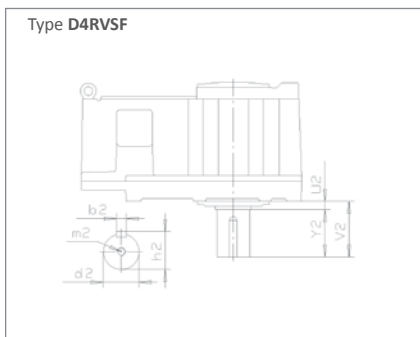

Solid shaft downwards

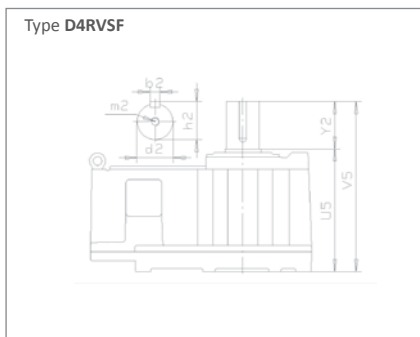

Solid shaft upwards

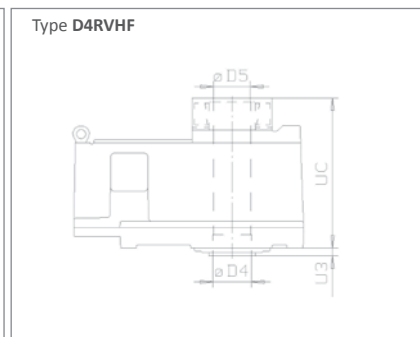

Hollow shaft, shrink disk, page 12.13

Common accessories, see section 12

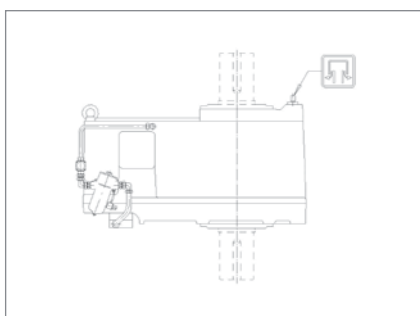

Shaft end pump, page 12.24
 with pressure lubrication

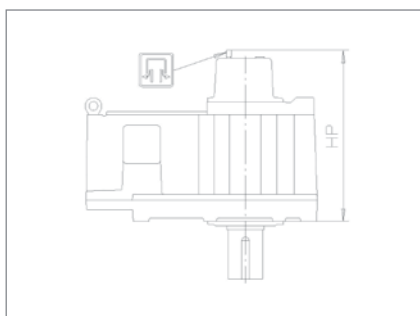

Expansion tank with bath lubrication

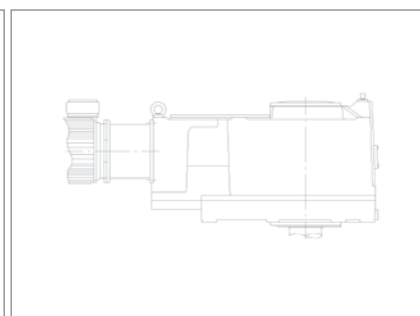

Motor flange, page 12.32

Size	LSS dimensions in mm													Common accessories
	Solid shaft					Hollow shaft					HP			
	d2	b2	h2	m2	Y2	U2	V2	U5	V5	U3		UC	D4	D5
60	160m6	40h9	169	M30	270	35	305	674	944	35	796	180	179	984
70	180m6	45h9	190	M30	270	35	305	725	995	35	863	190	189	1084
80	200m6	45h9	210	+)	315	35	350	785	1100	35	928	210	209	1275
90	220m6	50h9	231	+)	315	35	350	855	1170	35	1024	250	249	1350

+) M20,2x180°, distance 0.6xd2

Other available accessories, see section 12

Lubrication	Page
Lubrication unit	12.23
Oil heating system	12.27
Expansion tank for moist environment	12.29
Optional seal arrangements	12.30
Lip seal on HSS and LSS	2)

Coupled equipment	Page
Couplings	*)
Coupling guard	12.31
Belt drive	12.32

2) Standard solution for this gear unit type
 *) Contact Santasalo

See also modifications, page 12.35-12.37

Hollow shaft bore and driven shaft end for hollow shaft gear units types TC-N, TKC-N and TKCV-N

Standard mounting; sizes 140 - 250

Gear units
 2TC - N
 3TC - N
 4TC - N
 3TKC - N
 5TKC - N
 3TKCV - N

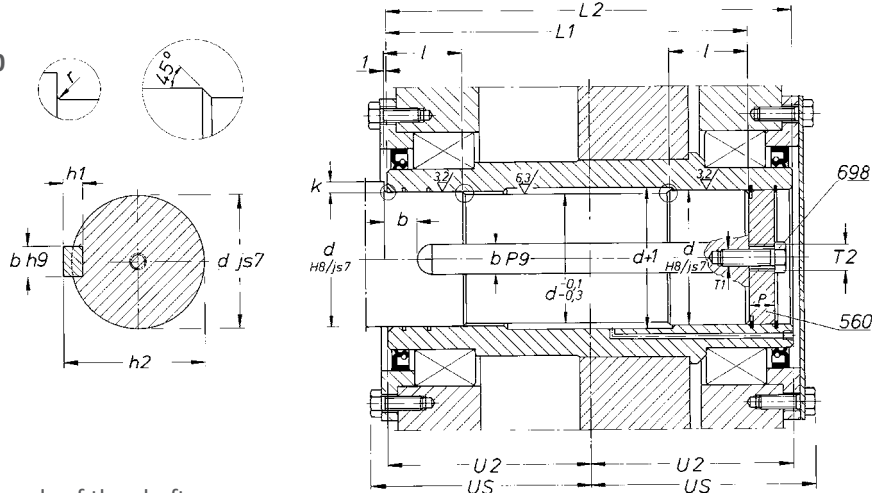

The diameter d is the same at both ends of the shaft.

Size	Dimensions in mm																
	d	b	h1	h2	k 1)		r	l	L1	L2	P	T1	T2	U2	US	pos.698 2)	
	stand				min	max	max					SFS 5037 DIN 332				Size	Pcs
140	70	20	12	74,5	4	23	3	35	165	200	20	M20x42	M24	100	114	M20x60	1
160	80	22	14	85	4	23	3	40	201	236	20	M20x42	M24	118	131	M20x60	1
180	90	25	14	95	4	33	3	45	208	250	24	M24x50	M30	125	139	M24x70	1
200	100	28	16	106	6	33	4	50	228	270	24	M24x50	M30	135	149	M24x70	1
225	110	28	16	116	6	33	4	55	266	308	24	M24x50	M30	154	167	M24x70	1
250	120	32	18	127	6	38	4	60	302	344	24	M24x50	M30	172	187	M24x70	1

Standard mounting; sizes 280 - 400

Gear units 3TKCV - N

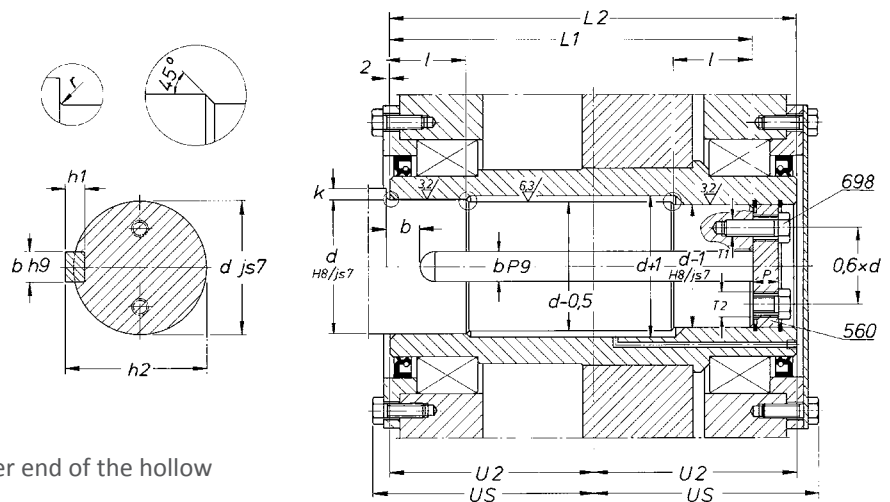

The diameter d is smaller at the outer end of the hollow shaft.

Size	Dimensions in mm																
	d	b	h1	h2	k 1)		r	l	L1	L2	P	T1	T2	U2	US	pos.698 2)	
	stand				min	max	max					SFS 5037 DIN 332				Size	Pcs
280	140	36	20	148	6	38	4	70	342	384	24	M20x42	M24	192	206	M20x60	2
315	160	40	22	169	7	43	5	80	394	436	24	M20x42	M24	218	233	M20x60	2
355	180	45	25	190	7	43	5	90	430	480	30	M24x50	M30	240	256	M24x80	2
400	200	45	25	210	7	48	5	100	490	540	30	M24x50	M30	270	286	M24x80	2

1) Shoulder required only for through going shaft

2) Item 698 screws are not included in normal delivery.

2, 3, 4TC140N-250N
3, 5TKC140N-250N, 3TKCV140N-400N

Hollow shaft bore

Mounting on through going shaft; sizes 140 - 250

Gear units
2TC - N
3TC - N
4TC - N
3TKC - N
5TKC - N
3TKCV - N

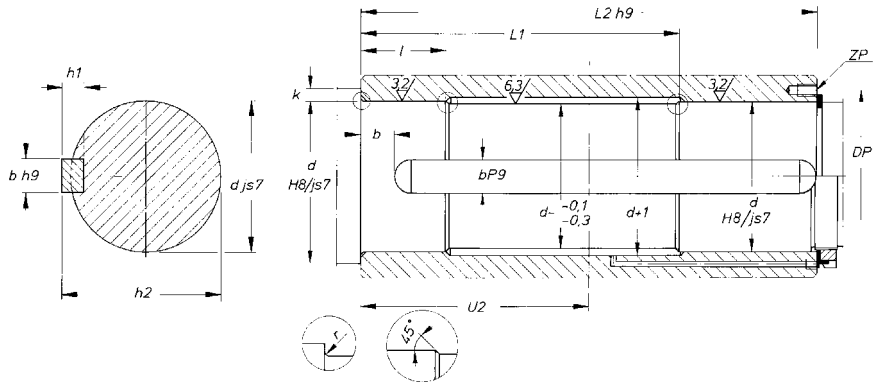

The diameter d is the same at both ends of the shaft.

Size	Dimensions in mm												
	d stand	b	h1	h2	k		r max	l	L1	L2	U2	DP	ZP
140	70	20	12	74,5	4	23	3	35	130	200	100	85	6xM8
160	80	22	14	85	4	23	3	40	161	236	118	95	6xM10
180	90	25	14	95	4	33	3	45	163	250	125	110	6xM10
200	100	28	16	106	6	33	4	50	178	270	135	120	6xM10
225	110	28	16	116	6	33	4	55	211	308	154	130	6xM10
250	120	32	18	127	6	38	4	60	242	344	172	145	6xM10

Mounting on through going shaft; sizes 280 - 400

Gear units
3TKCV - N

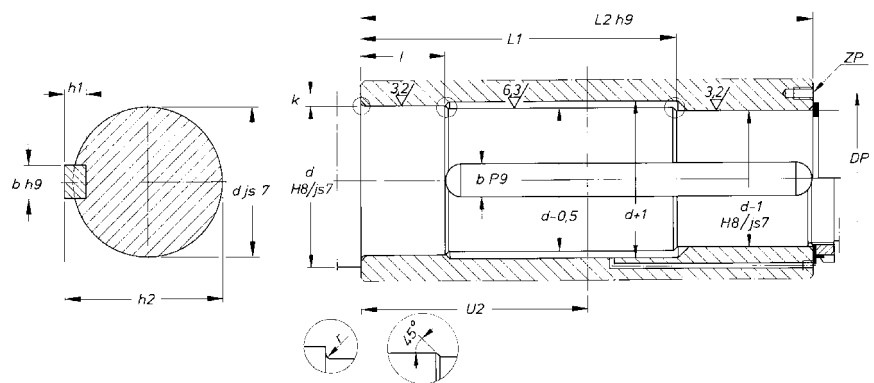

The diameter d is smaller at the outer end of the hollow shaft.

Size	Dimensions in mm												
	d stand	b	h1	h2	k		r max	l	L1	L2	U2	DP	ZP
280	140	36	20	148	6	38	4	70	272	384	192	165	6xM10
315	160	40	22	169	7	43	5	80	314	436	218	190	6xM12
355	180	45	25	190	7	43	5	90	340	480	240	210	6xM12
400	200	45	25	210	7	48	5	100	390	540	270	230	6xM12

Mounting with SANLO shrink disc; sizes 140 - 250

If not specified, the shrink disk shall be on the opposite side of the driven machine.

Gear units
 2TC - N
 3TC - N
 4TC - N
 3TKC - N
 5TKC - N
 3TKCV - N

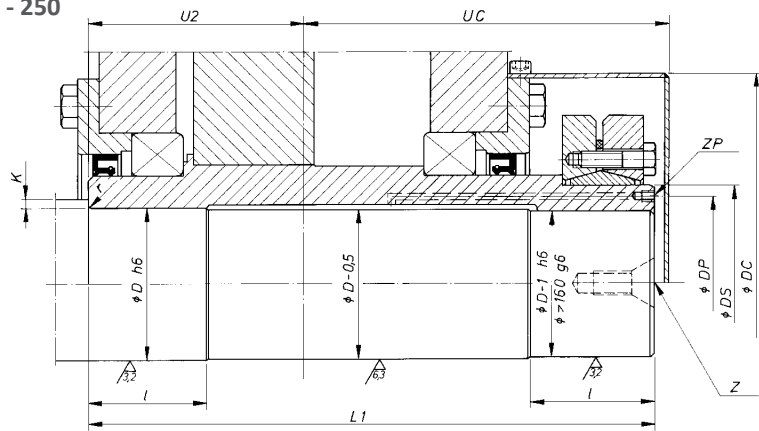

Size	Dimensions in mm														
	Shrink disc			Shaft end of driven machine						Hollow shaft		Cover			
	Size 1)	DS	Ma 2)	D	L1	l	k		r	U2	Z	DP	ZP	UC	DC
			Nm	stand			min	max	max		SFS5037 DIN 332				
140	90-S	90	30	70	263	44	4	23	3	100	M20	80	6xM6	172	194
160	100-S	100	30	80	301	48	4	23	3	118	M20	90	6xM6	194	204
180	110-S	110	59	90	324	55	4	33	3	125	M24	100	6xM6	214	244
200	125-S	125	59	100	349	60	6	33	4	135	M24	112	6xM8	227	254
225	140-S	140	100	110	393	65	6	33	4	154	M24	125	6xM8	250	264
250	165-S	165	250	120...(115)	441	75	6	38	4	172	M24	142	6xM8	280	306

- 1) Schaefer (TAS), Ringerfeder, Stüwe SD or Stüwe HSD shrink discs can be used.
- 2) Tightening torque of shrink disc screws.

Mounting with SANLO shrink disc ; sizes 280 - 400

Gear units
 3TKCV - N

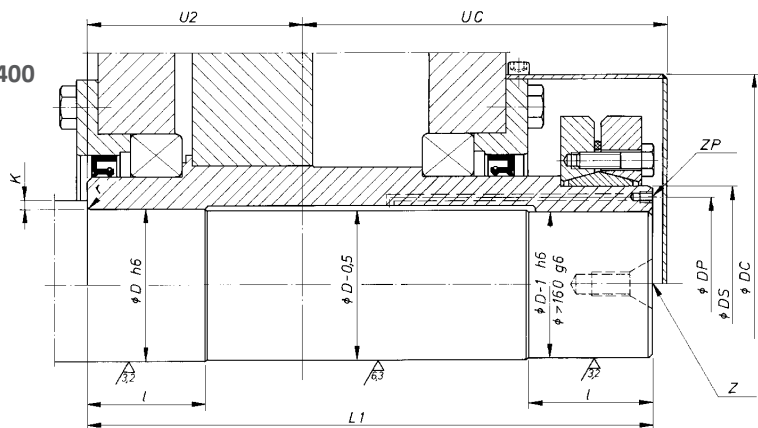

Size	Dimensions in mm														
	Shrink disc			Shaft end of driven machine						Hollow shaft		Cover			
	Size 1)	DS	Ma 2)	D	L1	l	k		r	U2	Z	DP	ZP	UC	DC
			Nm	stand			min	max	max		SFS5037 DIN 332				
280	175-S	175	250	140...(135)	478	78	6	38	4	192	M30	157	6xM8	298	324
315	200-S	200	250	160...(150)	551	95	7	43	5	218	M30	180	6xM10	345	364
355	220-S	220	250	180...(160)	616	112	7	43	5	240	M30	200	6xM10	390	384
400	240-S	240	490	200...(180)	680	115	7	48	5	270	M36	220	6xM10	427	436

Hollow shaft bore

Hollow shaft bore and driven shaft end for hollow shaft gear units types 2TKC-M

Standard mounting; sizes 90 - 250

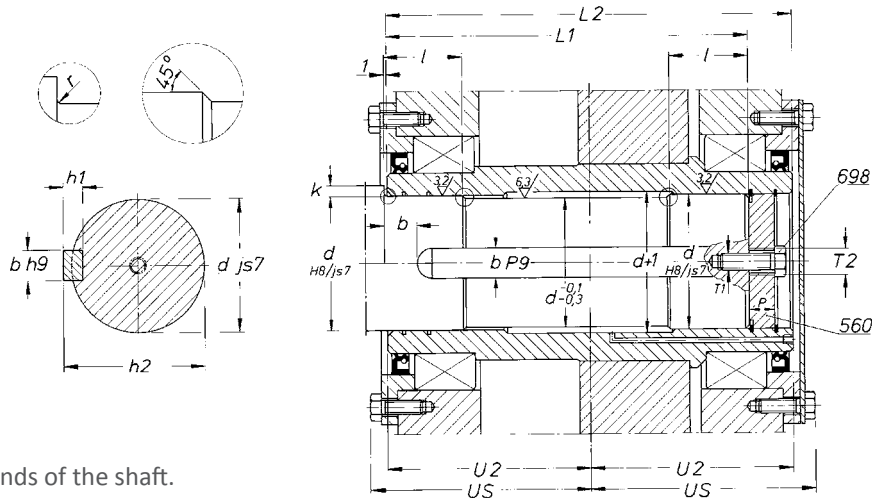

The diameter d is the same at both ends of the shaft.

Size	Dimensions in mm																
	d	b	h1	h2	k 1)		r	l	L1	L2	P	T1	T2	U2	US	pos.698 2)	
	stand				min	max	max					SFS 5037 DIN 332				Size Pcs	
2TKC90M	45	14	9	48.5	4	18	3	25	172	200	16	M16x36	M20	100	115	M16x50	1
2TKC110M	60	18	11	64	4	23	3	30	209	244	20	M20x42	M24	122	135	M20x60	1
2TKC140M	70	20	12	74.5	4	23	3	35	229	264	20	M20x42	M24	132	146	M20x60	1
2TKC180M	90	25	14	95	4	33	3	45	278	320	24	M24x50	M30	160	175	M24x70	1
2TKC225M	110	28	16	116	6	33	4	55	366	408	24	M24x50	M30	204	217	M24x70	1
2TKC250M	120	32	18	127	6	38	4	60	400	450	24	M24x50	M30	225	240	M24x70	1

Standard mounting; sizes 280 - 400

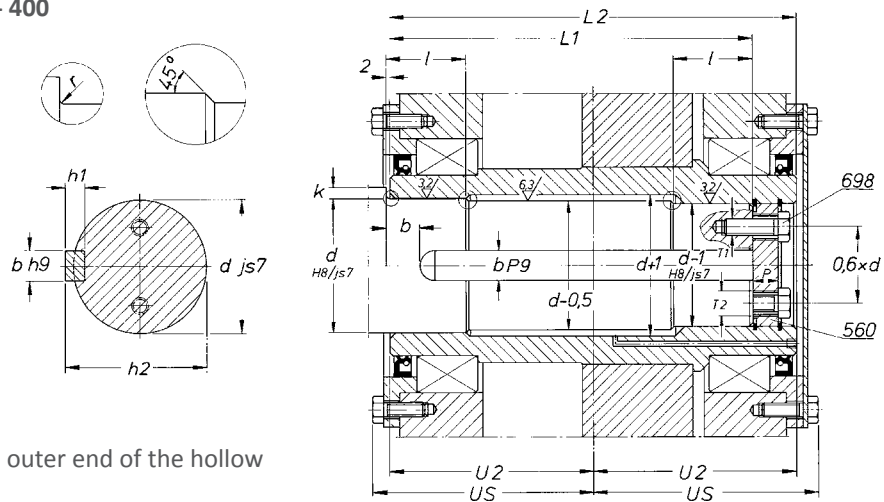

The diameter d is smaller at the outer end of the hollow shaft.

Size	Dimensions in mm																
	d	b	h1	h2	k 1)		r	l	L1	L2	P	T1	T2	U2	US	pos.698 2)	
	stand				min	max	max					SFS 5037 DIN 332				Size Pcs	
2TKC280M	140	36	20	148	6	38	4	70	470	516	24	M20x42	M24	258	272	M20x60	2
2TKC315M	160	40	22	169	7	43	5	80	530	582	24	M20x42	M24	291	306	M20x60	2
2TKC355M	180	45	25	190	7	43	5	90	580	634	30	M24x50	M30	317	333	M24x80	2
2TKC400M	200	45	25	210	7	48	5	100	660	722	30	M24x50	M30	361	377	M24x80	2

1) Shoulder required only for through going shaft
 2) Item 698 screws are not included in normal delivery.

Hollow shaft bore

Mounting with SANLO shrink disc; Sizes 90 - 400

If not specified, the shrink disk shall be on the opposite side of the driven machine.

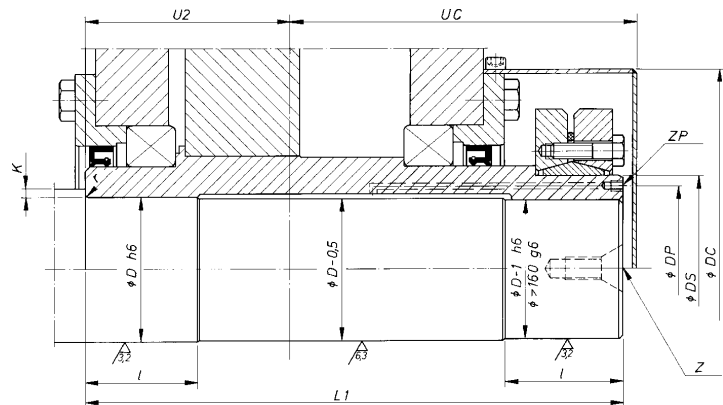

Size	Dimensions in mm														
	Shrink disc			Shaft end of driven machine						Hollow shaft		Cover			
	Size 1)	DS	Ma 2)	D	L1	l	k		r	U2	Z	DP	ZP	UC	DC
			Nm	stand			min	max	max		SFS5037				
2TKC90M	55-S	55	12	45	244	28	4	18	3	100	M16	-	-	152	134
2TKC110M	75-S	75	30	60	290	30	4	23	3	122	M20	-	-	177	174
2TKC140M	90-S	90	30	70	327	35	4	23	3	132	M20	80	6xM6	204	194
2TKC180M	110-S	110	59	90	394	45	4	33	3	160	M24	100	6xM6	250	244
2TKC225M	140-S	140	100	110	493	55	6	33	4	204	M24	125	6xM8	300	264
2TKC250M	165-S	165	250	120...(115)	547	65	6	38	4	225	M24	142	6xM8	333	306
2TKC280M	175-S	175	250	140...(135)	614	70	6	38	4	258	M30	157	6xM8	364	324
2TKC315M	200-S	200	250	160...(150)	697	85	7	43	5	291	M30	180	6xM10	418	364
2TKC355M	220-S	220	250	180...(160)	770	100	7	43	5	317	M30	200	6xM10	467	384
2TKC400M	240-S	240	490	200...(180)	862	110	7	48	5	361	M36	220	6xM10	518	436

- 1) Schaefer (TAS), Ringerfeder, Stüwe SD or Stüwe HSD shrink discs can be used.
- 2) Tightening torque of shrink disc screws.

Mounting on through going shaft; Sizes 90 - 250

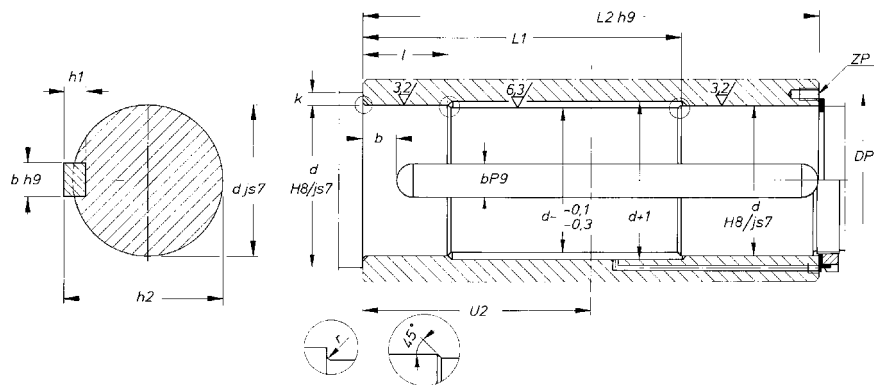

The diameter d is the same at both ends of the shaft.

Size	Dimensions in mm												
	d	b	h1	h2	k		r	l	L1	L2	U2	DP	ZP
	stand				min	max	max						
2TKC90M	45	14	9	48.5	4	18	3	25	147	200	100	55	6xM6
2TKC110M	60	18	11	64	4	23	3	30	179	244	122	73	6xM6
2TKC140M	70	20	12	74.5	4	23	3	35	194	264	132	85	6xM8
2TKC180M	90	25	14	95	4	33	3	45	233	320	160	110	6xM10
2TKC225M	110	28	16	116	6	33	4	55	311	408	204	130	6xM10
2TKC250M	120	32	18	127	6	38	4	60	340	450	225	145	6xM10

Hollow shaft bore

Mounting on through going shaft;
sizes 280 - 400

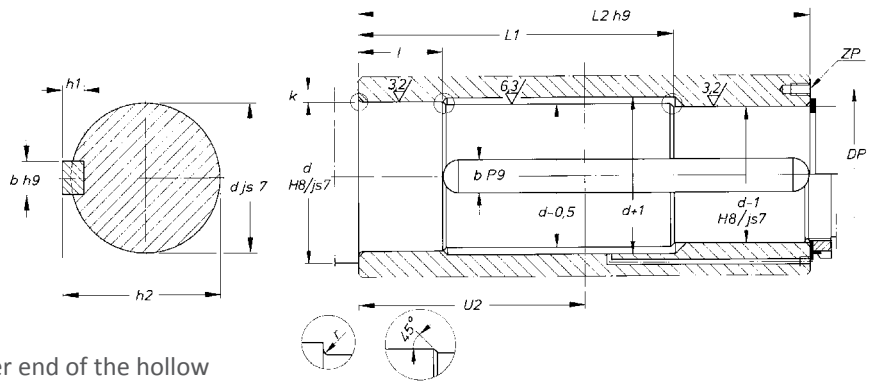

The diameter d is smaller at the outer end of the hollow shaft.

Size	Dimensions in mm												
	d	b	h1	h2	k		r	l	L1	L2	U2	DP	ZP
					min	max	max						
2TKC280M	140	36	20	148	6	38	4	70	400	516	258	165	6xM10
2TKC315M	160	40	22	169	7	43	5	80	450	582	291	190	6xM12
2TKC355M	180	45	25	190	7	43	5	90	490	634	317	210	6xM12
2TKC400M	200	45	25	210	7	48	5	100	560	722	361	230	6xM12

Shrink disk D-series

Hollow shaft bore and driven shaft end for hollow shaft gear units

If not specified, the shrink disk shall be on the opposite side of the driven machine.

Basic solution

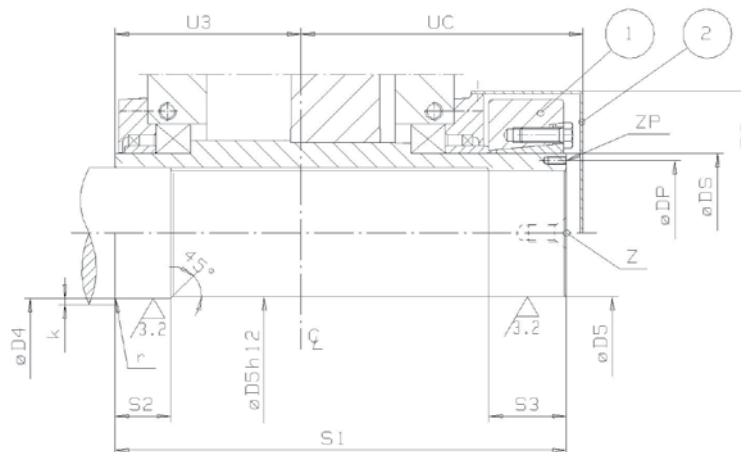

Item 1: Shrink disk
Item 2: Cover

Horizontal output shaft Mounting with shrink disk

Size	Dimensions in [mm]																	
	Shrink Disk		Shaft end of driven machine										Hollow Shaft		Cover			
	Size	Ma	øD4		øD5		S1	S2	S3	S4	S5	k	r	U3	øDP	ZP	øDC	UC
50	185/ d=190	190	250	135	155 js7/H8	154 h6/H7	548	78	85	463	548	7	5	228	172	M10x20	346	336
60	220/ d=220	220	490	160	180 js7/H8	179 g6/H7	620	90	102	518	620	7	5	255	200	M10x20	387	386
70	240/ d=240	240	490	180	190 js7/H8	189 g6/H7	683	95	105	578	683	7	5	284	215	M12x24	425	422
80	260/ d=260	260	490	190	210 js7/H8	209 g6/H7	730	105	120	610	730	8	6	302	235	M12x24	454	453
90	300/ d=300	300	840	230	250 js7/H8	249 g6/H7	796	125	140	656	796	8	6	324	275	M12x24	513	501

Z) Threaded holes according to customers standard. Recommended for assembly.

ZP) For disassembly tools.

*) Tightening torque of shrink disk screws.

Through going shaft

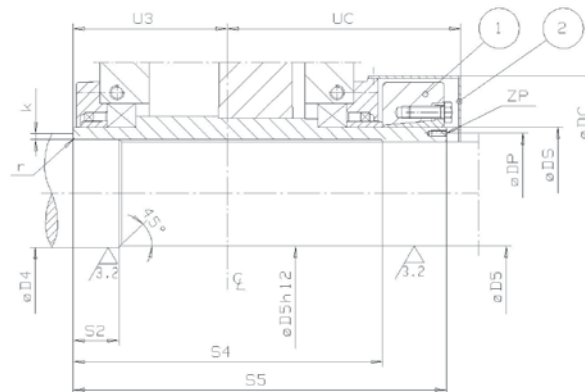

Item 1: Shrink disk
Item 2: Cover

Hollow shaft bore

Shrink disk D-series

Hollow shaft bore and driven shaft end for hollow shaft gear units

If not specified, the shrink disk shall be on the opposite side of the driven machine.

Basic solution

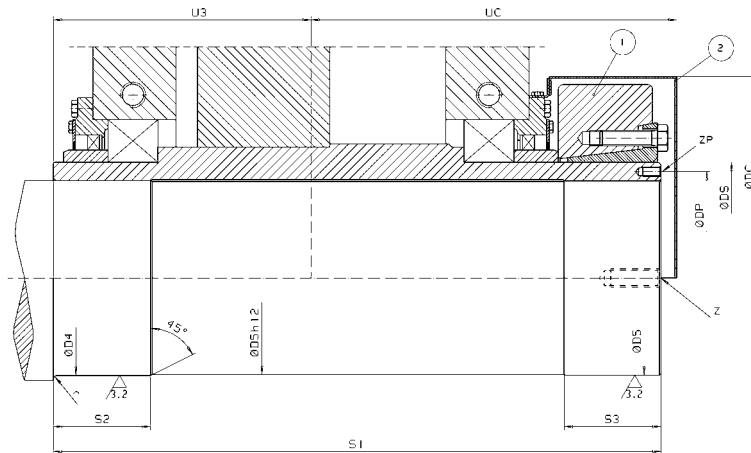

Item 1: Shrink disk
Item 2: Cover

Horizontal output shaft
Mounting with shrink disk

Size	Dimensions in [mm]																		
	Shrink Disk			Shaft end of driven machine										Hollow Shaft		Cover			
	size	ØDS	Ma *)	Standard		ØD4	ØD5	S1	S2	S3	S4	S5	r	U3	ØDP	ZP	ØDC	UC	
	std.		[Nm]	max.		min.							max		6x60°				
100	360	360	840	300 js7/H8	299 g6/H7	240	239	919	150	167	752	919	6	376	330	M16x30	620	570	
110	380	380	1250	320 js7/H8	319 g6/H7	270	269	975	160	175	800	975	6	401	350	M16x30	680	600	
120	400	400	1250	330 js7/H8	329 g6/H7	280	279	1055	165	196	859	1055	6	432	360	M20x40	700	650	
130	460	460	1250	380 js7/H8	379 g6/H7	300	299	1127	190	199	928	1127	6	464	420	M20x40	810	690	
140	480	480	1250	400 js7/H8	399 g6/H7	320	319	1208	200	218	990	1208	8	495	440	M20x40	840	745	
150	530	530	1250	450 js7/H8	449 g6/H7	360	359	1283	225	245	1038	1283	8	519	490	M20x40	950	800	
160	560	560	1250	460 js7/H8	459 g6/H7	380	379	1343	230	245	1098	1343	8	549	510	M24x50	1000	830	

Z) Threaded holes according to customers standard. Recommended for assembly.

ZP) For disassembly tools.

*) Tightening torque of shrink disk screws.

Through going shaft

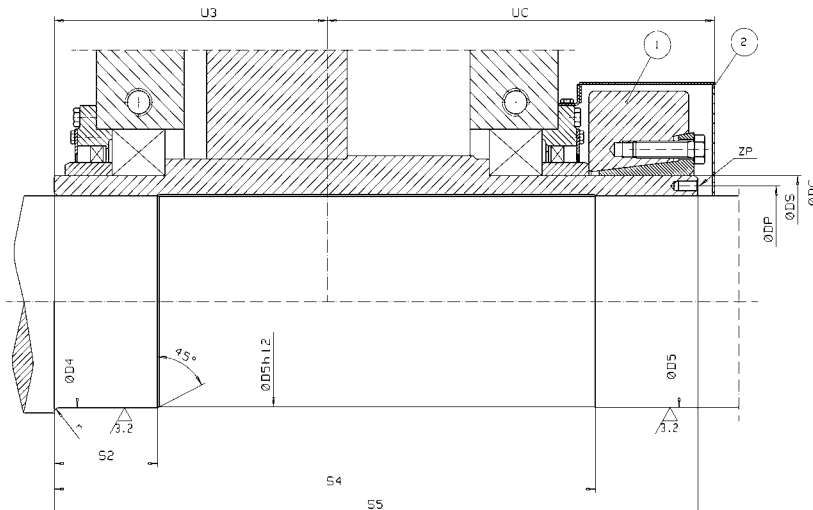

Item 1: Shrink disk
Item 2: Cover

Shrink disk D-series

Hollow shaft bore and driven shaft end for hollow shaft gear units

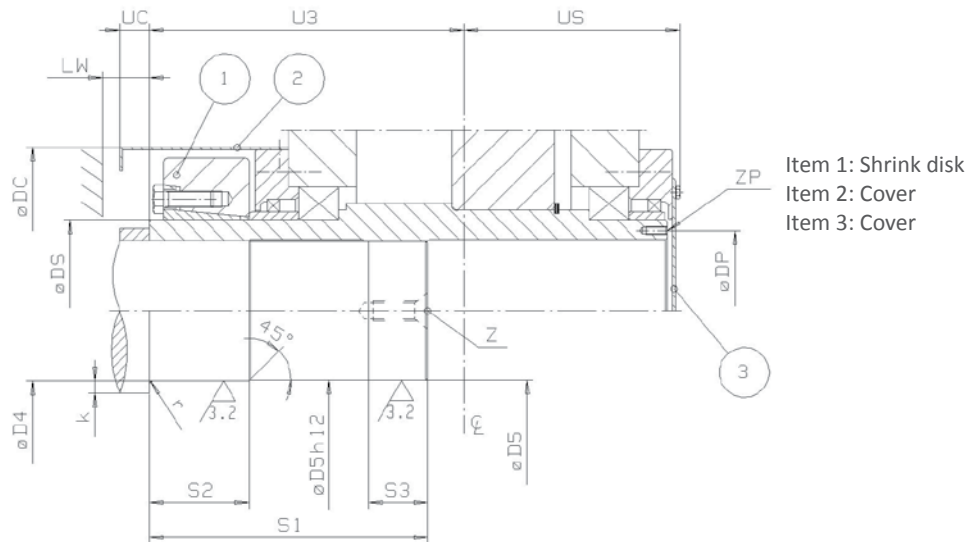

Horizontal output shaft Mounting with shrink disk

Size	Dimensions in [mm]																		
	Shrink Disk			Shaft end of driven machine									Hollow Shaft		Cover				
	Size	Ma	*)	øD4			øD5	S1	S2	S3	k	r	U3	øDP	ZP	øDC	LW	US	UC
	stand.	[Nm]	min.	stand.	stand.	stand.	min	max	max	min	max	max	6x60°	min.	min.	min.	min.	min.	min.
50	185/ d=190	190	250	135	155 h6/H7	154 js6/H7	310	85	40	7	18	5	320	172	M10x20	346	75	232	60
60	220/ d=220	220	490	160	180 g6/H7	179 js6/H7	360	102	45	7	20	5	365	200	M10x20	387	100	259	85
70	240/ d=240	240	490	180	190 g6/H7	189 js6/H7	380	105	50	7	25	5	399	215	M12x24	425	100	288	85
80	260/ d=260	260	490	190	210 g6/H7	209 js6/H7	420	120	55	8	25	6	428	235	M12x24	454	100	306	85
90	300/ d=300	300	840	230	250 g6/H7	249 js6/H7	500	140	65	8	25	6	472	275	M12x24	513	100	328	85

Z) Threaded holes according to customers standard. Recommended for assembly.

ZP) For disassembly tools.

*) Tightening torque of shrink disk screws.

Hollow shaft bore

Key connection D-series

Hollow shaft bore and driven shaft end for hollow shaft gear units

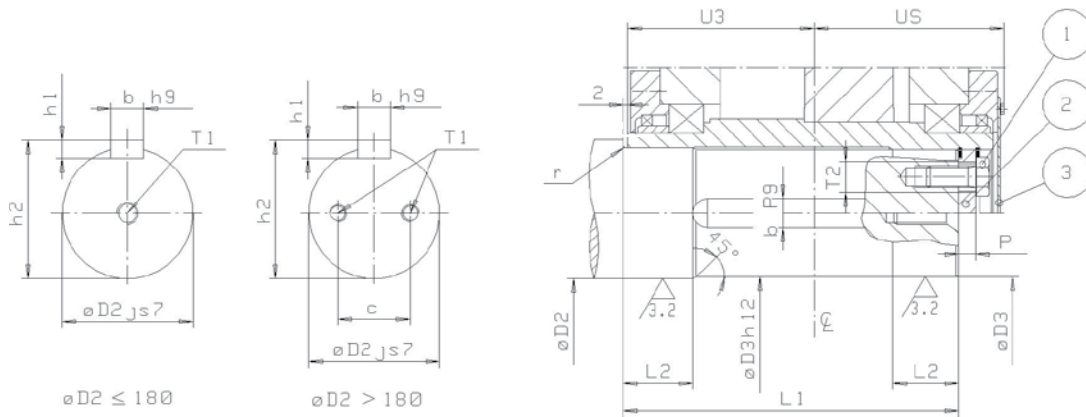

Shaft end

- Item 1: Screws are not included in normal delivery
- Item 2: End plate
- Item 3: Cover

Horizontal output shaft
Standard mounting with Key

Size	Dimensions in mm																						
	$\varnothing D2$		$\varnothing D3$	L1	L2	L4	L5	P	T1	c	T2	U3	U5	ZP	$\varnothing DP$	Screw		b	h1	h2	k *)		r
	min	Standard												6x60°	Size	Pcs				min	max		
50	135	150 js7/H8	149 js7/H8	394	75	381	456	24	M30x60	-	M36	228	232	M10x20	172	M30x80	1	36	20	158	6	4	
60	160	170 js7/H8	169 js7/H8	448	85	425	510	24	M30x60	-	M36	255	259	M10x20	200	M30x80	1	40	22	179	7	5	
70	180	190 js7/H8	189 js7/H8	506	95	473	568	30	M20x36	114	M24	284	288	M12x24	215	M20x60	2	45	25	200	7	5	
80	190	210 js7/H8	209 js7/H8	542	105	499	604	30	M20x36	126	M24	302	306	M12x24	235	M20x60	2	50	28	221	8	6	
90	230	240 js7/H8	239 js7/H8	586	120	528	648	30	M24x45	144	M30	324	328	M12x24	275	M24x70	2	56	32	252	8	6	

*) Shoulder required only for through going shaft.

Through going shaft

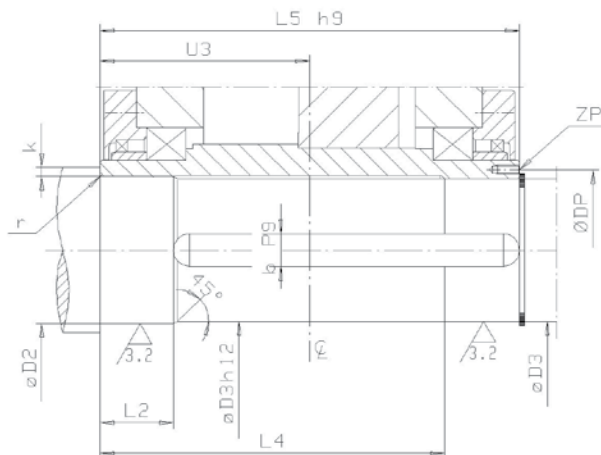

Key connection D-series

Hollow shaft bore and driven shaft end for hollow shaft gear units

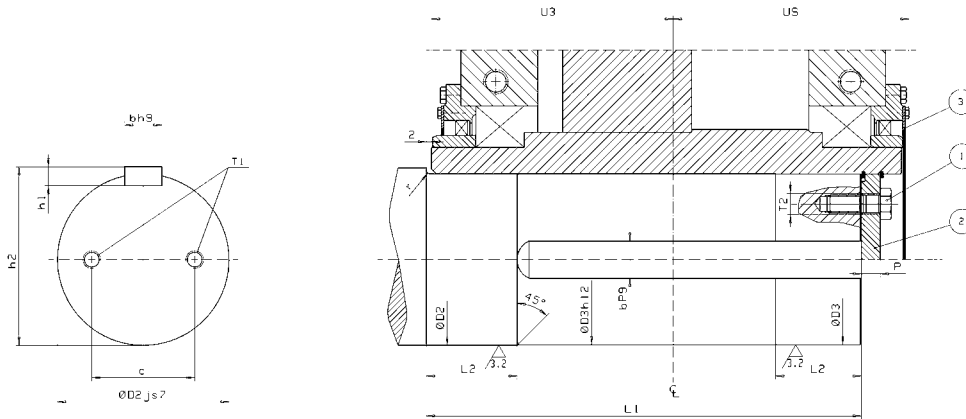

Shaft end

- Item 1: Screws are not included in normal delivery
- Item 2: End plate
- Item 3: Cover

Horizontal output shaft Standard mounting with Key

Size	Dimensions in [mm]																						
	Standard		ØD2	ØD3	L1	L2	L4	L5	P	T1	c	T2	U3	U5	ZP	ØDP	Screw	b	h1	h2	k*)		r
	max.	min.																			min	max	
100	280 js7/H8	279 js7/H8	240	239	671	140	612	752	32	M24x70	168	M30	376	370	M16x30	320	M24x100	2	63	32	292	8	6
110	290 js7/H8	289 js7/H8	270	269	721	145	657	802	32	M24x70	174	M30	401	395	M16x30	350	M24x100	2	63	32	302	8	6
120	300 js7/H8	299 js7/H8	280	279	783	150	714	864	32	M24x70	180	M30	432	425	M20x40	350	M24x100	2	70	36	314	8	6
130	340 js7/H8	339 js7/H8	300	299	842	170	758	928	36	M30x80	204	M36	464	455	M20x40	400	M30x110	2	80	40	355	8	6
140	360 js7/H8	359 js7/H8	320	319	904	180	810	990	36	M30x80	216	M36	495	490	M20x40	420	M30x110	2	80	40	375	10	8
150	400 js7/H8	399 js7/H8	360	359	952	200	838	1038	36	M30x80	240	M36	519	510	M20x40	465	M30x110	2	90	45	417	10	8
160	420 js7/H8	419 js7/H8	380	379	1011	210	888	1098	36	M30x80	252	M36	549	540	M24x50	490	M30x110	2	90	45	437	10	8

*) Shoulder required only for through going shaft.

Through going shaft

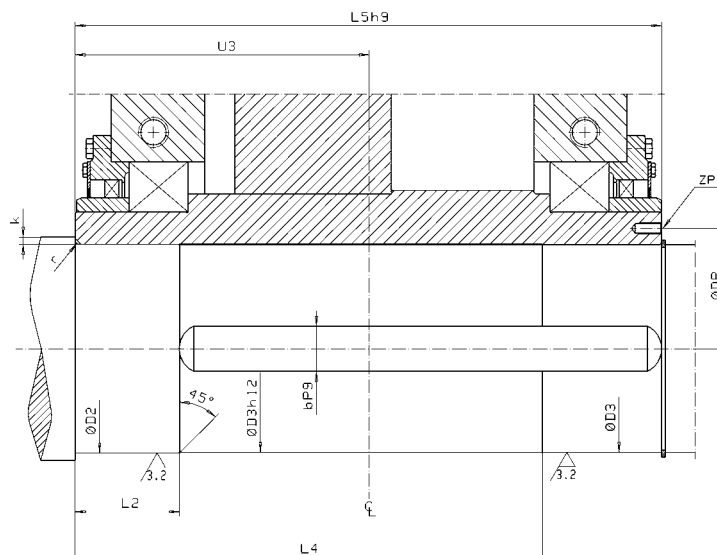

Hollow shaft bore

Key connection D-series

Hollow shaft bore and driven shaft end for hollow shaft gear units

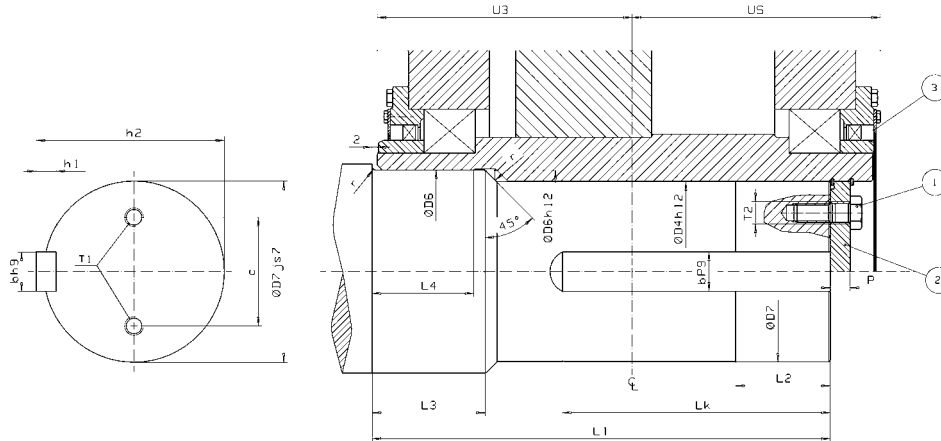

Shaft end

- Item 1: Screws are not included in normal delivery
- Item 2: End plate
- Item 3: Cover

Horizontal output shaft
Special mounting with Key

Size	Dimensions in (mm)																		
	OD6 max.	OD7 Standard	Lk	L1	L2	L3	L4	P	T1	c	T2	U3	U5	Screw Size	Pcs	b	h1	h2	r max
100	315 js7/H8	279 js7/H8	420	671	140	190	160	32	M24x70	168	M30	376	370	M24x100	2	63	32	291	6
110	325 js7/H8	289 js7/H8	435	721	145	200	165	32	M24x70	174	M30	401	395	M24x100	2	63	32	301	6
120	340 js7/H8	299 js7/H8	450	783	150	205	172	32	M24x70	180	M30	432	425	M24x100	2	70	36	313	6
130	385 js7/H8	339 js7/H8	510	842	170	215	185	36	M30x80	204	M36	464	455	M30x110	2	80	40	354	6
140	400 js7/H8	359 js7/H8	540	904	180	225	202	36	M30x80	216	M36	495	490	M30x110	2	80	40	374	8
150	450 js7/H8	399 js7/H8	600	952	200	230	227	36	M30x80	240	M36	519	510	M30x110	2	90	45	416	8
160	465 js7/H8	419 js7/H8	630	1011	210	245	235	36	M30x80	252	M36	549	540	M30x110	2	90	45	436	8

*) Shoulder required only for through going shaft.

Shrink disk D-series

Hollow shaft bore and driven shaft end for hollow shaft gear units

Basic solution

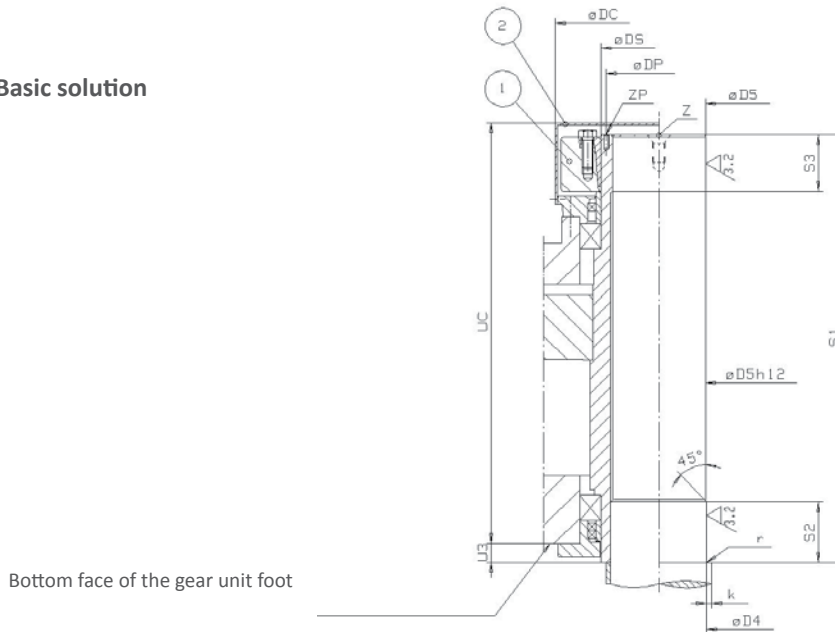

Item 1: Shrink disk
Item 2: Cover

Bottom face of the gear unit foot

Vertical output shaft Mounting with shrink disk

Size	Dimensions in [mm]																	
	Shrink Disk			Shaft end of driven machine									Hollow Shaft		Cover			
	Size	øDS	Ma	øD4			øD5	S1	S2	S3	k		r	U3	øDP	ZP	øDC	UC
	stand.		[Nm]	min.	stand.					min	max	max			6x60°			
10	110/ d=110	110	100	75	85 js7/H8	84 h6/H7	453	45	48	4	12	3	25	97	M6x12	205	445	
20	125/ d=120	120	100	85	95 js7/H8	94 h6/H7	476	50	52	5	12	3	25	107	M6x12	235	470	
30	155/ d=150	150	160	110	120 js7/H8	119 h6/H7	564	62	62	6	15	4	25	135	M6x12	280	555	
40	155/ d=160	160	160	115	130 js7/H8	129 h6/H7	605	65	62	6	15	4	25	145	M8x16	285	600	
50	185/ d=190	190	250	135	155 js7/H8	154 h6/H7	704	78	85	7	18	5	25	172	M10x20	346	700	
60	220/ d=220	220	490	160	180 js7/H8	179 g6/H7	810	90	102	7	20	5	35	200	M10x20	387	796	
70	240/ d=240	240	490	180	190 js7/H8	189 g6/H7	875	95	105	7	25	5	35	215	M12x24	425	863	
80	260/ d=260	260	490	190	210 js7/H8	209 g6/H7	938	105	120	8	25	6	35	235	M12x24	454	928	
90	300/ d=300	300	840	230	250 js7/H8	249 g6/H7	1030	125	140	8	25	6	35	275	M12x24	513	1024	

Z) Threaded holes according to customers standard. Recommended for assembly.

ZP) For disassembly tools.

*) Tightening torque of shrink disk screws.

Hollow shaft bore

Shrink disk D-series

Hollow shaft bore and driven shaft end for hollow shaft gear units

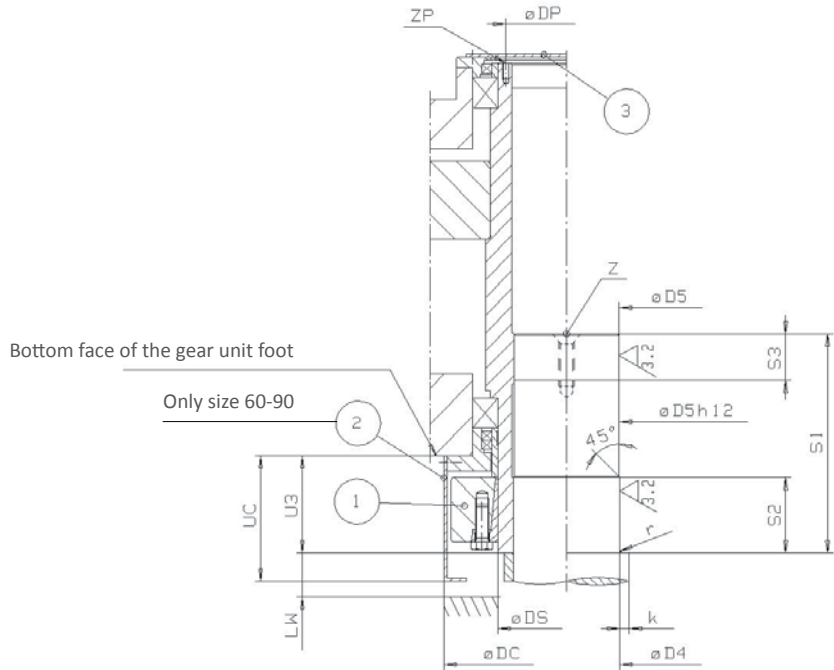

- Item 1: Shrink disk
- Item 2: Cover (sizes 60-90)
- Item 3: Cover

Vertical output shaft
Mounting with shrink disk

Size	Dimensions in [mm]																	
	Shrink Disk			Shaft end of driven machine							Hollow Shaft			Cover				
	Size	Ma	*)	øD4		øD5	S1	S2	S3	k		r	U3	øDP	ZP	øDC	UC	LW
stand.	øDS	[Nm]	min.	stand.					min	max	max			6x60°				
10	110/ d=110	110	100	75	85 h6/H7	84 js6/H7	170	48	20	4	12	3	80	97	M6x12	205	135	70
20	125/ d=120	120	100	85	95 h6/H7	94 js6/H7	190	52	25	5	12	3	84	107	M6x12	235	140	70
30	155/ d=150	150	160	110	120 h6/H7	119 js6/H7	250	62	30	6	12	4	94	135	M6x12	285	155	75
40	155/ d=160	160	250	115	130 h6/H7	129 js6/H7	260	62	35	6	15	4	94	145	M8x16	285	155	75
50	185/ d=190	190	250	135	155 h6/H7	154 js6/H7	310	85	40	7	18	5	117	172	M10x20	346	179	75
60	220/ d=220	220	490	160	180 g6/H7	179 js6/H7	360	102	45	7	20	5	148	200	M10x20	387	235	100
70	240/ d=240	240	490	180	190 g6/H7	189 js6/H7	380	105	50	7	25	5	152	215	M12x24	425	240	100
80	260/ d=260	260	490	190	210 g6/H7	209 js6/H7	420	120	55	8	25	6	164	235	M12x24	454	250	100
90	300/ d=300	300	840	230	250 g6/H7	249 js6/H7	500	140	65	8	25	6	185	275	M12x24	513	270	100

Z) Threaded holes according to customers standard. Recommended for assembly.

ZP) For disassembly tools.

*) Tightening torque of shrink disk screws.

Hollow shaft bore

Key connection D-series

Hollow shaft bore and driven shaft end for hollow shaft gear units

- Item 1: Screws are not included in normal delivery
- Item 2: End plate
- Item 3: Cover

Bottom face of the gear unit foot

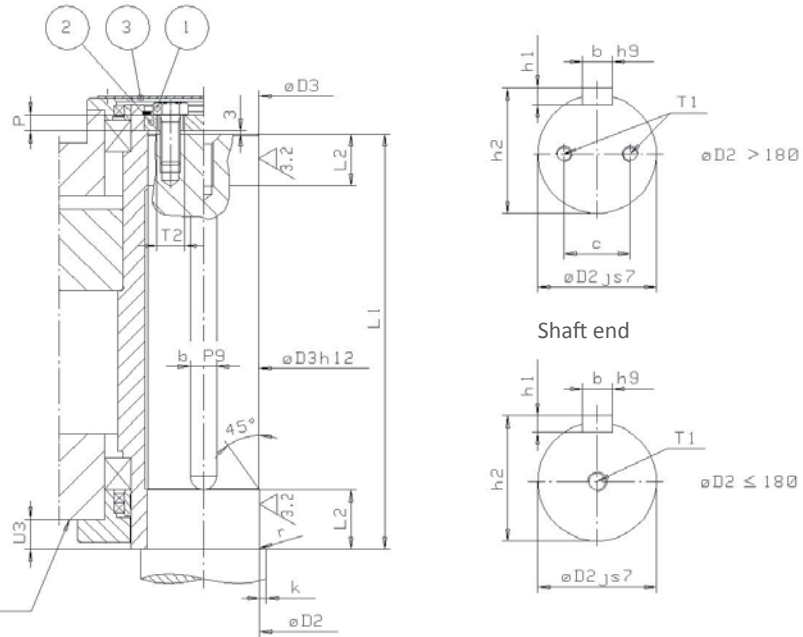

Vertical output shaft Standard mounting with key

Size	Dimensions in mm																	
	øD2		øD3	L1	L2	U3	T1	c	T2	P	Screw		b	h1	h2	k		r
	min	standard									Size	Pcs				min	max	max
10	75	85 js7/H8	84 js7/H8	350	45	25	M20x42	-	M24	20	M20x60	1	22	14	90	4	12	3
20	85	95 js7/H8	94 js7/H8	365	50	25	M24x50	-	M30	20	M24x60	1	25	14	100	5	12	3
30	110	120 js7/H8	119 js7/H8	440	60	25	M24x50	-	M30	24	M24x70	1	32	18	127	6	15	4
40	115	130 js7/H8	129 js7/H8	480	65	25	M24x50	-	M30	24	M24x70	1	32	18	137	6	15	4
50	135	150 js7/H8	149 js7/H8	550	75	25	M30x60	-	M36	24	M30x80	1	36	20	158	6	20	4
60	160	170 js7/H8	169 js7/H8	635	85	35	M30x60	-	M36	24	M30x80	1	40	22	179	7	25	5
70	180	190 js7/H8	189 js7/H8	695	95	35	M20x36	114	M24	30	M20x60	2	45	25	200	7	25	5
80	190	210 js7/H8	209 js7/H8	750	105	35	M20x36	126	M24	30	M20x60	2	50	28	221	8	25	6
90	230	240 js7/H8	239 js7/H8	820	120	35	M24x45	144	M30	30	M24x70	2	56	32	252	8	30	6

Through going HSS

Through going HSS

Type D1P.. 20 - 130

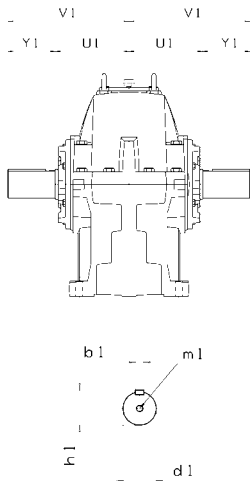

Size	HSS dimensions in mm																		
	i _N =1.0...3.55						i _N =4.0...4.5						i _N =5.0...7.1						
	U1	Y1	V1	d1	b1	h1	m1	Y1	V1	d1	b1	h1	m1	Y1	V1	d1	b1	h1	m1
20	150	95	245	45k6	14h9	48.5	M16	70	220	35k6	10h9	38	M12	60	210	25k6	8h9	28	M10
30	175	125	300	60m6	18h9	64	M20	95	270	50k6	14h9	53.5	M16	70	245	35k6	10h9	38	M12
40	209	125	334	75m6	20h9	79.5	M20	125	334	65m6	18h9	69	M20	95	304	45k6	14h9	48.5	M16
50	259	150	409	90m6	25h9	95	M24	150	409	85m6	22h9	90	M20	125	384	60m6	18h9	64	M20
60	296	190	486	110m6	28h9	116	M24	190	486	100m6	28h9	106	M24	150	446	80m6	22h9	85	M20
70	311	190	501	120m6	32h9	127	M24	190	501	110m6	28h9	116	M24	150	461	90m6	25h9	95	M24
80	340	225	565	130m6	32h9	137	M24	190	530	120m6	32h9	127	M24	190	530	100m6	28h9	106	M24
90	370	225	595	150m6	36h9	158	M30	225	595	140m6	36h9	148	M30	190	560	120m6	32h9	127	M24
100	390	270	660	170m6	40h9	179	M30	270	660	160m6	40h9	169	M30	225	615	135m6	36h9	143	M30
110	421	315	736	190m6	45h9	200	M20(1)	270	691	180m6	45h9	190	M30	225	646	150m6	36h9	158	M30
120	440	315	755	210m6	50h9	221	M20(1)	315	755	190m6	45h9	200	M20(1)	270	710	160m6	40h9	169	M30
130	460	315	775	230m6	50h9	241	M24(1)	315	775	210m6	50h9	221	M20(1)	270	730	170m6	40h9	179	M30

1) 2 x 180°, distance 0,6 x d1

Type D2P.. 50 - 110

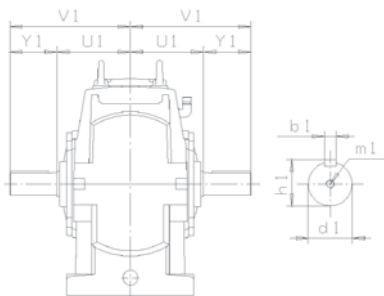

Size	HSS dimensions in mm												
	i _N =6.3...12.5						i _N =14...18						
	U1	Y1	V1	d1	b1	h1	m1	Y1	V1	d1	b1	h1	m1
50	238	125	363	75m6	20h9	79.5	M20	125	363	60m6	18h9	64	M20
60	255	150	405	80m6	22h9	85	M20	125	380	70m6	20h9	74.5	M20
70	287	150	437	95m6	25h9	100	M24	150	437	80m6	22h9	85	M20
80	307	190	497	100m6	28h9	106	M24	150	457	85m6	22h9	90	M20
90	330	190	520	110m6	28h9	116	M24	150	480	95m6	25h9	100	M24
100	380	225	605	130m6	32h9	137	M24	190	570	120m6	32h9	127	M24
110	405	225	630	140m6	36h9	148	M30	225	630	130m6	32h9	137	M24

Type D3P.. 50 - 160

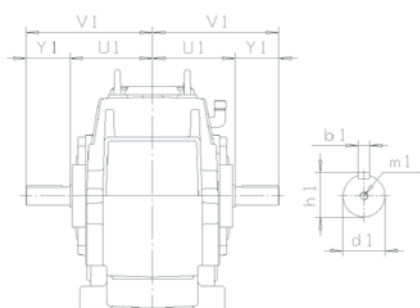

Size	HSS dimensions in mm												
	i _N =20...63						i _N =71...90						
	U1	Y1	V1	d1	b1	h1	m1	Y1	V1	d1	b1	h1	m1
50	226	95	321	50k6	14h9	53.5	M16	95	321	40k6	12h9	43	M16
60	251	95	346	55m6	16h9	59	M20	95	346	45k6	14h9	48.5	M16
70	280	125	405	65m6	18h9	69	M20	95	375	55m6	16h9	59	M20
80	300	125	425	70m6	20h9	74.5	M20	125	425	60m6	18h9	64	M20
90	322	150	472	80m6	22h9	85	M20	125	447	70m6	20h9	74.5	M20
100	374	150	524	90m6	25h9	95	M24	150	524	80m6	22h9	85	M20
110	399	150	549	95m6	25h9	100	M24	150	549	85m6	22h9	90	M20
120	430	190	620	100m6	28h9	106	M24	150	580	95m6	25h9	100	M24
130	462	190	652	110m6	28h9	116	M24	190	652	100m6	28h9	106	M24
140	504	190	694	120m6	32h9	127	M24	190	694	110m6	28h9	116	M24
150	528	225	753	130m6	32h9	137	M24	190	718	115m6	32h9	122	M24
160	558	225	783	140m6	36h9	148	M30	190	748	120m6	32h9	127	M24

Shaft positions

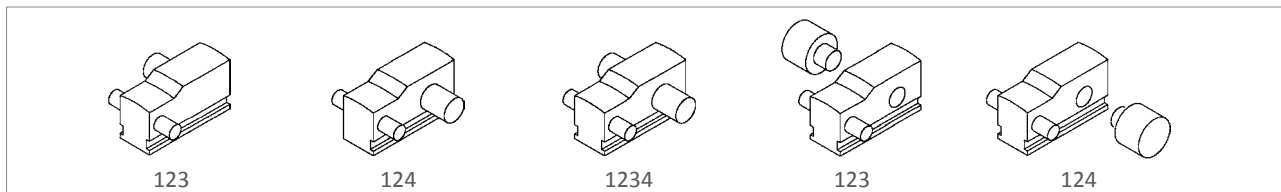

Mounting flange

Through going HSS

Type D4P.. 50 - 160

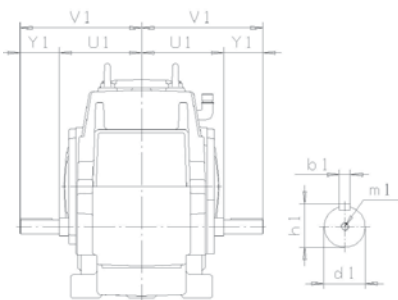

Size	HSS dimensions in mm														
	$i_N = 100...140$						$i_N = 160...400$								
	U1	Y1	V1	d1	b1	h1	m1	Y1	V1	d1	b1	h1	m1		
50	217	70	287	35k6	10h9	38	M12	70	287	30k6	8h9	33	M10		
60	244	95	339	40k6	12h9	43	M16	70	314	30k6	8h9	33	M10		
				$i_N = 100...225$						$i_N = 250...400$					
70	273	95	368	45k6	14h9	48.5	M16	95	368	40k6	12h9	43	M16		
80	291	95	386	50k6	14h9	53.5	M16	95	386	40k6	12h9	43	M16		
				$i_N = 100...140$						$i_N = 160...400$					
90	313	125	438	60m6	18h9	64	M20	95	408	50k6	14h9	53.5	M16		
				$i_N = 100...125$						$i_N = 140...400$					
100	375	125	500	65m6	18h9	69	M20	95	470	55m6	16h9	59	M20		
110	400	125	525	75m6	20h9	79.5	M20	125	525	60m6	18h9	64	M20		
				$i_N = 100$						$i_N = 112...400$					
120	431	150	581	80m6	22h9	85	M20	125	556	65m6	18h9	69	M20		
				$i_N = 100...125$						$i_N = 140...400$					
130	463	150	613	85m6	22h9	90	M20	125	588	70m6	20h9	74.5	M20		
				$i_N = 100$						$i_N = 112...400$					
140	494	150	644	90m6	25h9	95	M24	125	619	75m6	20h9	79.5	M20		
				$i_N = 100...140$						$i_N = 160...400$					
150	518	150	668	95m6	25h9	100	M24	150	668	80m6	22h9	85	M20		
160	548	190	738	100m6	28h9	106	M24	150	698	90m6	25h9	95	M24		

Mounting flange D-series

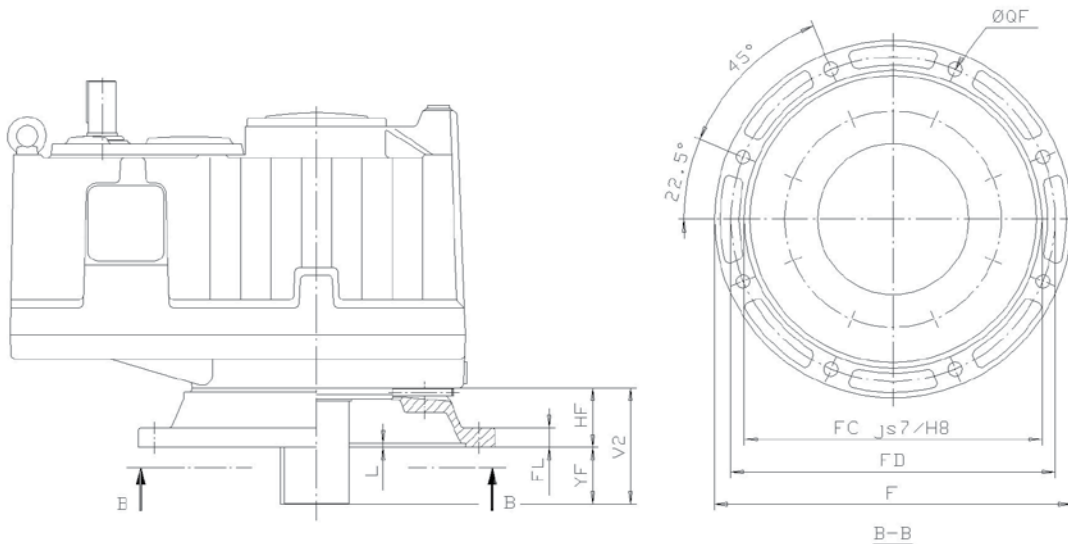

Vertical LSS

Size	F	FD	FC js7/H8	ØQF	L	FL	YF	HF	V2
10	450	400	350	18	6	24	65	110	175
20	480	430	380	22	6	25	65	110	175
30	560	500	450	26	6	30	105	110	215
40	660	600	550	26	7	36	105	110	215
50	820	740	680	33	7	45	140	110	250

Cooling fans

Cooling fans; gear units D1PSF20 - D1PSF130 and 2C140N - 2C250N

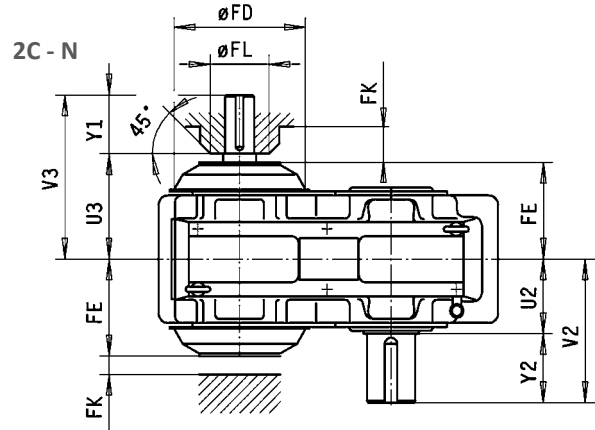
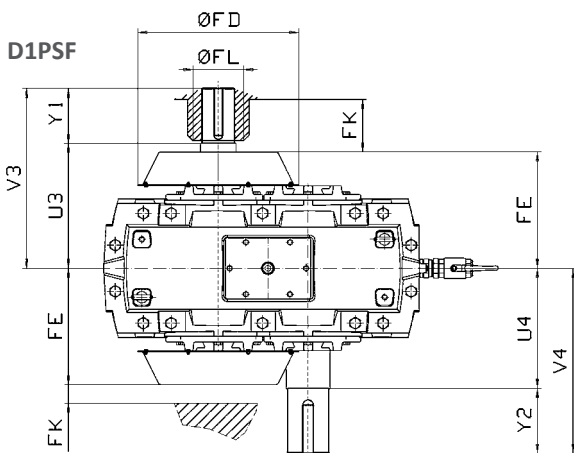

Note changes in dimensions

Size	Shaft dimensions in mm						Fan			
	Input shaft				Output shaft					
	U3	1.25<i>i</i> ≤4.0	4.0<i>i</i> ≤4.5	5.0<i>i</i> ≤7.1	U4	V4	FD	FE	FKmin	FLmax
D1PSF20	205	300	275	265	200	295	238	191	25	70
D1PSF30	250	375	345	320	235	360	291	226	30	95
D1PSF40	304	429	429	399	290	440	361	280	40	100

Size	Shaft dimensions in mm						Fan			
	Input shaft				Output shaft					
	U3	1.25<i>i</i> ≤4.0	4.0<i>i</i> ≤5.0	5.6<i>i</i> ≤7.1	U4	V4	FD	FE	FKmin	FLmax
D1PSF50	376	526	526	501	360	550	443	347	55	140
D1PSF60	432	622	622	582	415	640	547	403	65	170
D1PSF70	447	637	637	597	430	655	547	418	65	170
D1PSF80	500	725	690	690	480	750	684	468	80	220
D1PSF90	530	755	755	720	510	825	684	498	80	220
D1PSF100	550	820	820	775	530	845	684	518	80	220

Size	Shaft dimensions in mm				Fan			
	Input shaft							
	U3	5.9<i>i</i> ≤13	13<i>i</i> ≤21	V3	FD	FE	FKmin	FLmax
2C140N	179	256	259	190	169	25	60	
2C160N	195	305	275	190	185	25	60	
2C180N	209	319	319	240	199	30	95	
2C200N	244	354	354	300	224	40	110	
2C225N	262	402	372	300	242	40	110	
2C250N	280	420	420	300	260	40	110	

Cooling fans; gear units 2TC140N - 2TC250N

Note changes in dimensions

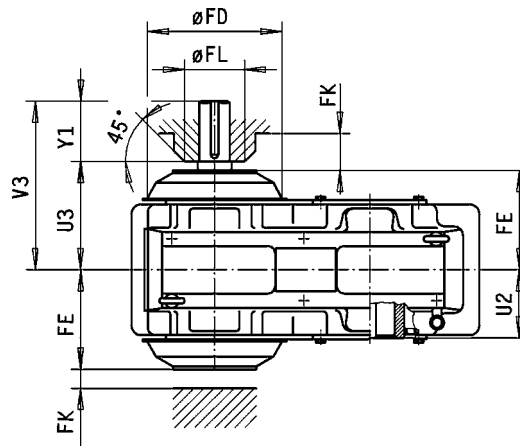

Size	Shaft dimensions in mm			Fan			
	Input shaft			FD	FE	FKmin	FLmax
	U3	5.9<i ≤13	13<i ≤21				
2TC140N	179	256	259	190	169	25	60
2TC160N	195	305	275	190	185	25	60
2TC180N	209	319	319	240	199	30	95
2TC200N	244	354	354	300	224	40	110
2TC225N	262	402	372	300	242	40	110
2TC250N	280	420	420	300	260	40	110

Non-wearing labyrinth seal for D1PSF and 2C gear units

A labyrinth seal develops no friction. The way it works is based on grooves which prevent oil from leaking. This means labyrinth seals are practically everlasting. The labyrinth seal is protected against external impurities by a V-ring.

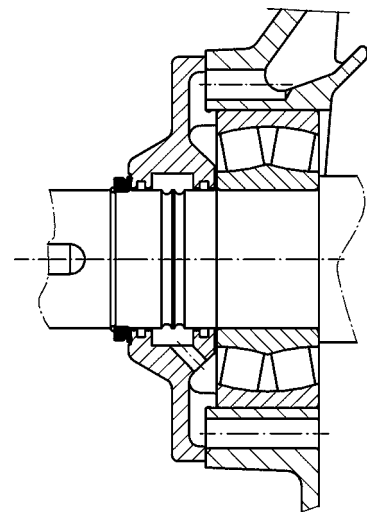

Cooling fans

2KC-M gear units equipped with fan

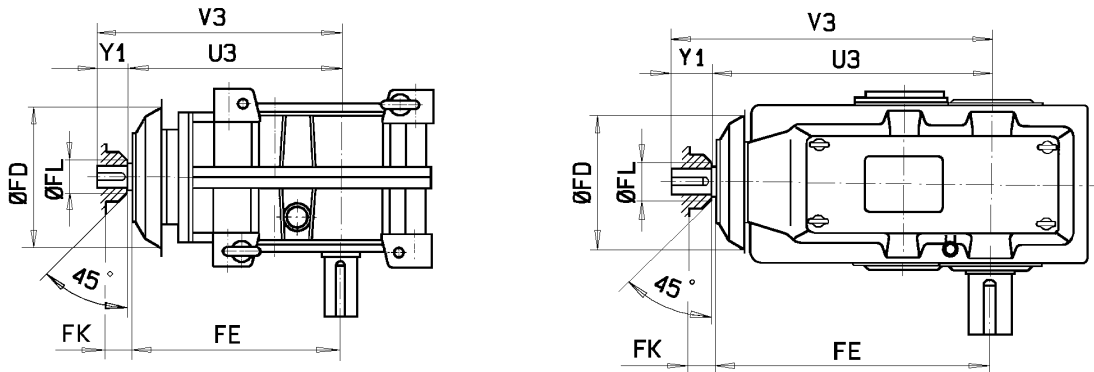

Size	Shaft dimensions in mm				Fan			
	Input shaft				FD	FE	FKmin	FLmax
	U3	3.8<i ≤10.6	10.6<i ≤15	15<i ≤21				
2KC90M	310	352	346	335	190	296	25	60
2KC110M	370	428	412	398	190	355	25	60
2KC140M	460	542	518	496	240	447	30	95
2KC180M	570	652	652	628	240	556	30	95
2KC225M	725	830	807	807	300	702	40	110
2KC250M	800	905	905	882	300	777	40	110
2KC280M	905	1035	1010	987	380	879	55	140
		3.8<i ≤10.6	10.6<i ≤15	15<i ≤21				
2KC315M	1000	1165	1130	1105	380	974	55	140
2KC355M	1140	1305	1270	1245	475	1108	65	160
2KC400M	1270	1435	1435	1375	475	1237	65	160

2TKC-M gear units equipped with fan

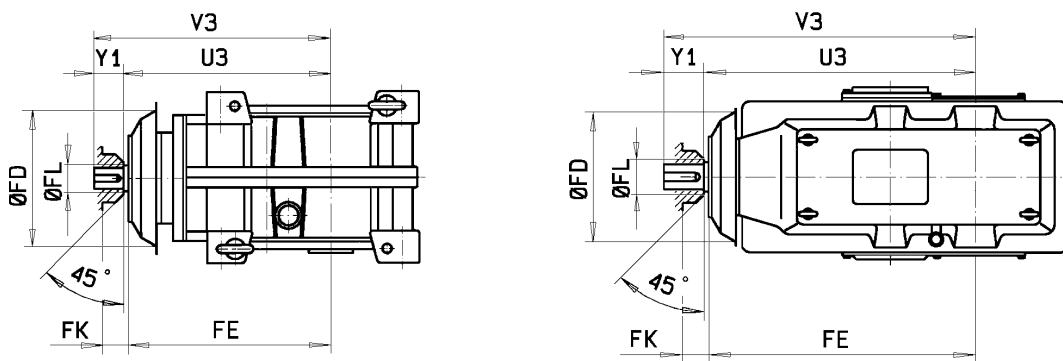

Size	Shaft dimensions in mm				Fan			
	Input shaft				FD	FE	FKmin	FLmax
	U3	3.8<i ≤10.6	10.6<i ≤15	15<i ≤21				
2TKC 90M	310	352	346	335	190	296	25	60
2TKC110M	370	428	412	398	190	355	25	60
2TKC140M	460	542	518	496	240	447	30	95
2TKC180M	570	652	652	628	240	556	30	95
2TKC225M	725	830	807	807	300	702	40	110
2TKC250M	800	905	905	882	300	777	40	110
2TKC280M	905	1035	1010	987	380	879	55	140
		3.8<i ≤10.6	10.6<i ≤15	15<i ≤21				
2TKC315M	1000	1165	1130	1105	380	974	55	140
2TKC355M	1140	1305	1270	1245	475	1108	65	160
2TKC400M	1270	1435	1435	1375	475	1237	65	160

Fan

Types D2P., D3P..

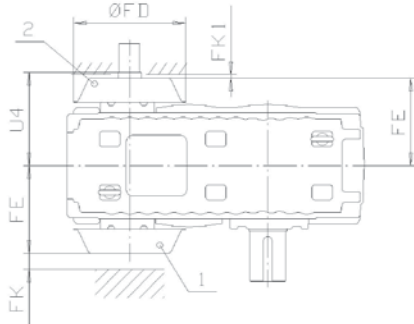

1. Fan on the HSS at the opposite side as the motor
2. Fan on the HSS

Gear unit	Fan *)	n_{1max} 1/min	U4	ØFD	FE	FK _{min}	FK1 _{min}
D2P50	Ø315	3000	355	443	326	55	20
D2P60	Ø315	3000	372	443	343	55	20
D2P70	Ø400	2350	423	547	394	65	20
D2P80	Ø400	2350	443	547	414	65	20
D2P90	Ø400	2350	466	547	437	65	20

*) Outer diameter of the Fan

Gear unit	Fan *)	n_{1max} 1/min	U4	ØFD	FE	FK _{min}	FK1 _{min}
D3P50	Ø315	3000	343	443	314	55	20
D3P60	Ø315	3000	367	443	338	55	20
D3P70	Ø400	2350	417	547	388	65	20
D3P80	Ø400	2350	435	547	406	65	20
D3P90	Ø400	2350	457	547	428	65	20
D3P100	Ø400	2350	510	547	481	65	20
D3P110	Ø400	2350	535	547	506	65	20
D3P120	Ø400	2350	566	547	537	65	20
D3P130	Ø400	2350	598	547	569	65	20

*) Outer diameter of the Fan

Type D3R..

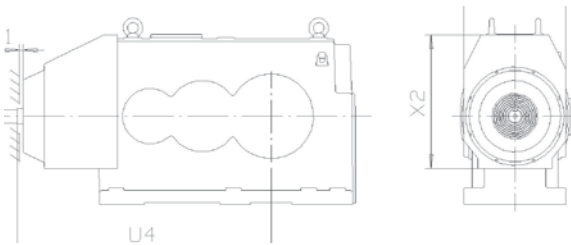

Gear unit	Fan *)	n_{1max} 1/min	U4	X1	X2	FK1 _{min}
D3R50	Ø315	3000	998	462	570	20
D3R60	Ø315	3000	1129	516	654	20
D3R70	Ø400	2350	1278	574	758	20
D3R80	Ø400	2350	1328	610	838	20
D3R90	Ø400	2350	1499	654	916	20

*) Outer diameter of the Fan

Type D3RV..

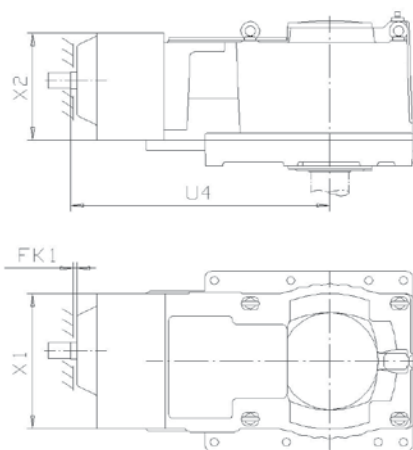

Gear unit	Fan *)	n_{1max} 1/min	U4	X1	X2	FK1 _{min}
D3RV30	Ø200	3000	758	450	371	15
D3RV40	Ø250	3000	821	504	423	15
D3RV50	Ø315	3000	995	590	491	20
D3RV60	Ø315	3000	1114	640	519	20
D3RV70	Ø400	2350	1269	740	607	20
D3RV80	Ø400	2350	1320	800	625	20
D3RV90	Ø400	2350	1493	846	652	20

*) Outer diameter of the Fan

Cooling coil system

Cooling coil system

Cooling coil is used with bath and splash lubrication when no fan can be used because of environment.

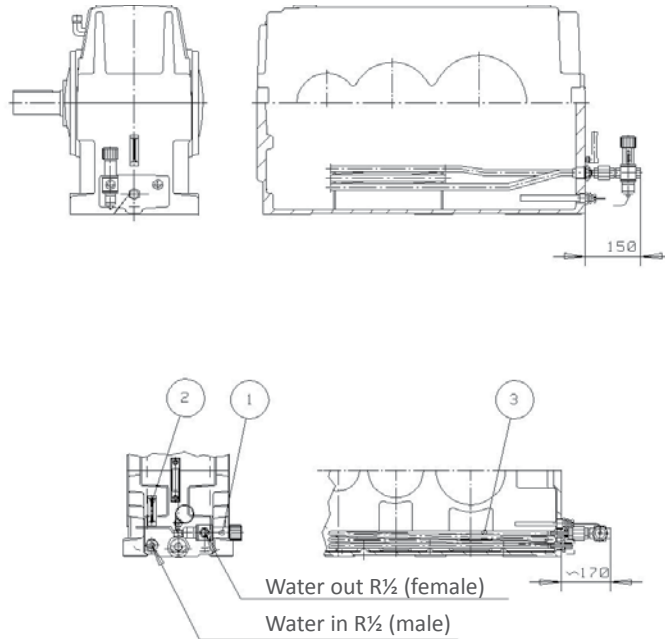

Components:

- 1. Thermostatic water valve
- 2. Thermometer, scale 0 ... 100 oC (+32 ... +212 oF)
- 3. Cooling pipe, material AISI 316

Thermal ratings with cooling coil system

Size	Thermal ratings P_{TW} in kW ($n_1=1500$ 1/min) Water supply temp. +20°C																							
	D1PSF20-130																							
	Oil surface temperature in the oil sump 80°C / Mineral oil												Oil surface temperature in the oil sump 90°C / Synthetic oil											
	$i_N = 1.0 \dots 1.8$				$i_N = 2.0 \dots 3.55$				$i_N = 4.0 \dots 7.1$				$i_N = 1.25 \dots 1.8$				$i_N = 2.0 \dots 3.55$				$i_N = 4.0 \dots 7.1$			
20 °C	30 °C	40 °C	50 °C	20 °C	30 °C	40 °C	50 °C	20 °C	30 °C	40 °C	50 °C	20 °C	30 °C	40 °C	50 °C	20 °C	30 °C	40 °C	50 °C	20 °C	30 °C	40 °C	50 °C	
20	89	71	54	37	92	75	57	40	94	77	59	42	106	89	71	54	110	92	75	57	111	94	77	59
30	157	130	102	75	161	133	105	78	161	133	106	78	185	157	130	102	188	161	133	105	189	161	133	106
40	233	191	149	107	239	197	155	113	241	199	157	115	275	233	191	149	281	239	197	155	283	241	199	157
50	400	334	268	202	405	339	273	207	403	337	271	205	466	400	334	268	471	405	339	273	469	403	337	271
60	561	477	393	309	560	476	392	308	550	466	382	298	645	561	477	393	644	560	476	392	634	550	466	382
70	683	575	467	359	688	580	472	364	681	573	465	357	791	683	575	467	796	688	580	472	789	681	573	465
80	836	704	572	440	842	710	578	446	833	701	569	437	968	836	704	572	974	842	710	578	965	833	701	569
90	936	786	636	486	945	795	645	495	937	787	637	487	1086	936	786	636	1095	945	795	645	1087	937	787	637
100	1090	907	724	541	1107	924	741	558	1106	923	740	557	1273	1090	907	724	1290	1107	924	741	1289	1106	923	740

Lubrication unit

1. Efficiency

Following minimum efficiency values at full load situation can be applied to helical and bevel-helical gear units:

- 1-stage: $\eta = 0.985^1 = 0.985$
- 2-stage: $\eta = 0.985^2 = 0.970$
- 3-stage: $\eta = 0.985^3 = 0.956$
- 4-stage: $\eta = 0.985^4 = 0.941$
- 5-stage: $\eta = 0.985^5 = 0.927$

2. Power loss to be cooled

Power loss P_L to be cooled (kW)

$$P_L = P_{k1} \left(\frac{PT}{2} \right) (1-\eta)$$

Where:

- P_{k1} Running power in HSS (kW)
- P_T Thermal rating (kW) (from catalogue)
- η Efficiency

3. Required oil flow for cooling

The equation for the cooling demand Q_R (dm³/min)

$$Q_R = 2,3 \frac{\text{dm}^3/\text{min}}{\text{kW}} P_L$$

4. Oil cooling

The highest permitted operating temperature for a gear unit, measured at the gear bearing housing, is normally +80°C. The gear unit can be cooled by:

- incorporating a water cooled oil cooler
- incorporating an air cooled oil cooler

An air cooled oil cooler at thermostat controlled water valve is fitted on the inlet side. The maximum permitted water pressure is 1 MPa (10 bar). The direction of water flow in the oil coolers should be according to the instructions.

In water cooled oil coolers the amount of water flow should be regulated by thermostat so that the temperature of the oil entering the gear unit is in range of +45...+55°C.

If the gear unit has an air cooled oil cooler this is also provided with a thermostat to control the cooling fan motor so that the temperature of the oil entering the gear unit is in range of +45...+55°C.

5. Required flow for water coolers

Required water flow Q_w (dm³/min) for pipe coolers can be calculated as below:

$$Q_w = 1,5 \dots 3,0 \frac{\text{dm}^3/\text{min}}{\text{kW}} P_L$$

Where:

- P_L power loss to be cooled (kW)
- 1.5 for clean water
- 3.0 for dirty water

Required water flow Q_w (dm³/min) for plate coolers can be calculated as below:

$$Q_w \leq 2 P_L$$

6. Choosing the size of oil cooler

$$P_c \geq F_L \cdot P_L$$

Where

- P_L power loss to be cooled (kW)
- F_L safety factor for cooling capacity

The estimation of cooling rating can be calculated as:

$$P_c \approx 0.48 \cdot Q_p$$

Where

- Q_p oil capacity of the pump (dm³/min)

7. Checking the oil capacity of the gear unit (V_G)

$$V_G \geq 2 \cdot Q_p$$

See catalog section 3 for oil capacities.

Shaft end pump

Shaft end pump

Available pump outputs Q_p : 11, 18, 28, 44, 65 dm³ /min at 1500 rpm.
 When additional cooling is required use lubrication unit with water or air cooler

1. Shaft end pump for gear unit with vertical output shaft

- shaft end pump is used when
- pressure lubrication is required and a motor pump is unpreferable.
 - dry well design is required and a motor pump is unpreferable.

When designing the gear unit mounting plate, adequate space must be allowed for the SHP pump.

GEAR UNIT SIZE 10 - 50

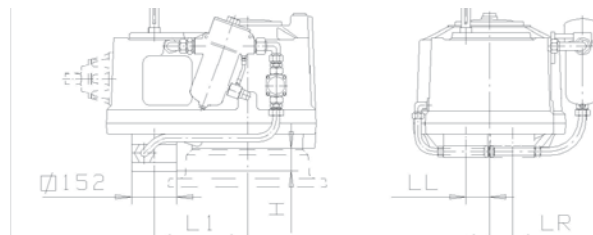

GEAR UNIT SIZE 60 - 90

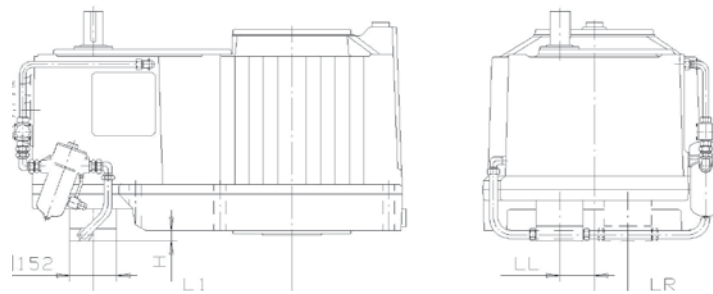

Size	H _{max}	Types	
		D2PV.,D3PV.,D3RV..	
		L1	LL
10	77	266	7
20	78	278	16
30	61	353	16
40	56	396	25

Size	H _{max}	Types		Types	
		D2PV., D3RV..		D3PV.,D4PV.,D4RV..	
		L1	LL	L1	LR
50	47	471	27	511	69
60	28	531	109	606	95
70	26	614	95	694	146
80	21	665	93	745	148
90	17	731	87	811	186

2. Shaft end pump for gear units with horizontal output shaft

The shaft end pump, type SHP, is used when pressure lubrication is needed and a motor pump is unpreferable.

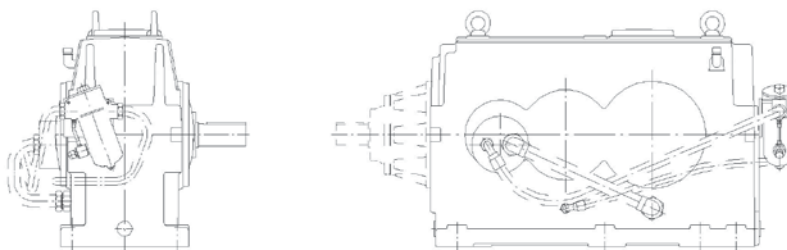

Central lubrication system connections

Equipment to connect the gear unit to the centralised oil filtering and cooling system.

SPLASH LUBRICATION

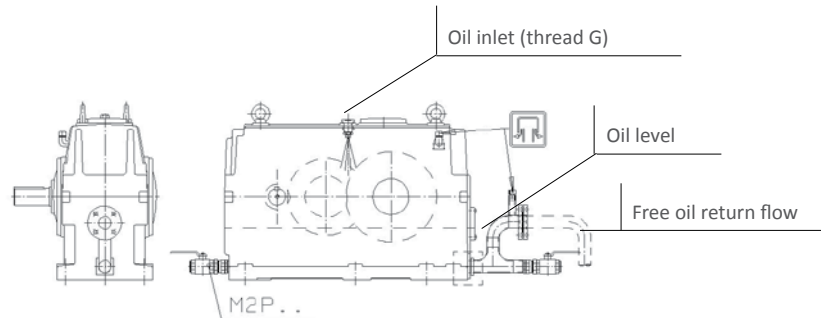

PRESSURE LUBRICATION

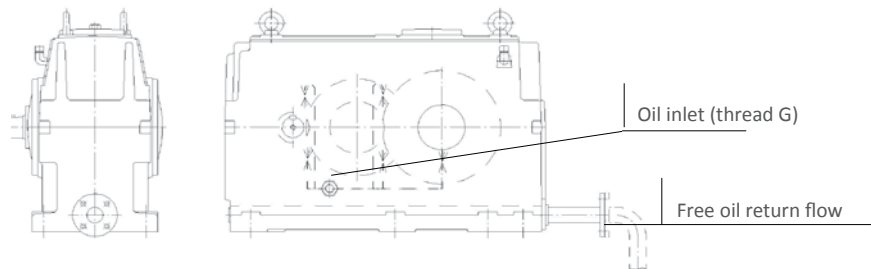

Thread R (female):

- G $\frac{3}{4}$, when $Q < 30$ l/min

- G $1\frac{1}{4}$, when $30 < Q < 80$ l/min

Q = oil flow

The diameter and height of the oil outlet pipe vary according to the gear unit size, lubrication method, oil viscosity and oil amount.

Santasalo can deliver a visual or electrical flow meter to ensure the right oil flow into the gear unit.

Dimensions of the attachment flange depend on the pipe diameter and are according to the standard DIN 2642.

Central lubrication system connections

Central lubrication system connections

Equipment to connect the gear unit to the centralised oil filtering and cooling system.

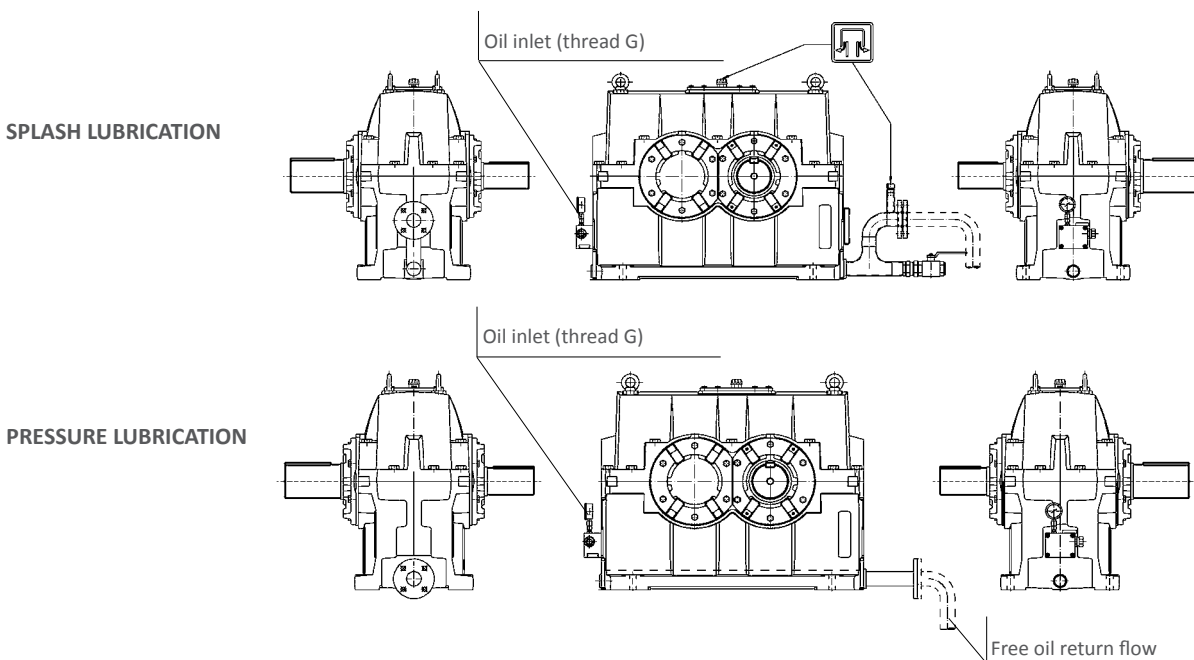

Dimensions of the attachment flange depend on the pipe diameter and are according to the standard DIN 2642

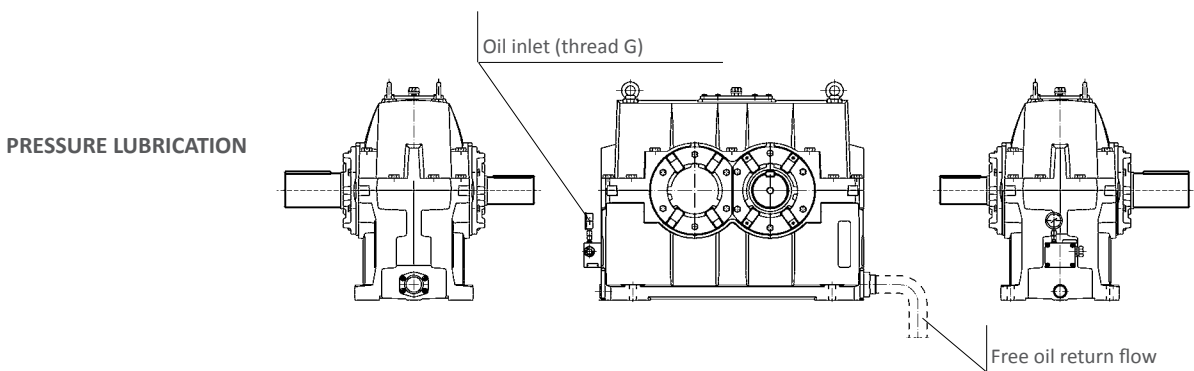

Dimensions of the attachment flange depend on the pipe diameter and are according to the standard SAE (ISO 6162-1/2).

Thread G (female):
 - G ¾ , when Q < 40 l/min Q = oil flow
 - G 1¼ , when 40 < Q < 92 l/min

The diameter and height of the oil outlet pipe vary according to the gear unit size, lubrication method, oil viscosity and oil amount.

Santasalo can deliver a visual or electrical flow meter to ensure the right oil flow into the gear unit.

Oil heating system

Oil heating system is used to ensure the function of the lubrication in cold condition start ups.

HORIZONTAL LSS

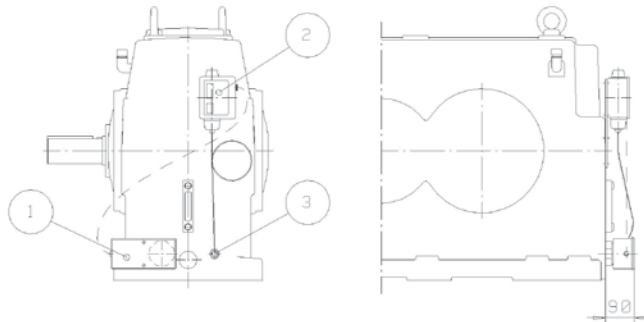

- Components
1. Oil heater
 2. Thermostat
 3. Sensor

Size	D2P., D3R Power [W]	D3P Power [W]	D4P., D4R., D5R Power [W]	Voltage[V]
50	1000	1000	1500	400/230
60	1500	1000	1500	400/230
70	1500	2000	2000	400/230
80	2000	1500 + 1500	2330	400/230
90	2330	1500 + 1500	2330	400/230

Size	D2P., D5R Power [W]	Voltage[V]
100	2330 + 2330	400/230
110	2330 + 2330	400/230
120	2330 + 2330	400/230
130	2330 + 2330	400/230
140	2330 + 2330	400/230
150	2330 + 2330	400/230
160	2330 + 2330	400/230

Size	D1PSF40-130 Power [W]	Voltage [V]
40	670	230
50	1500	400/230
60	1000+1500	400/230
70	1000+2000	400/230
80	1500+2000	400/230
90	1500+2330	400/230
100	1500+2330	400/230
110	1500+2330	400/230
120	2000+2330	400/230
130	2000+2330	400/230

VERTICAL LSS

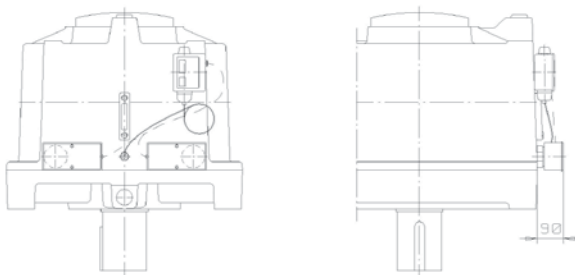

Gear units with vertical LSS

Size	Power [W]	Voltage [V]
D(R)PV ... 50	1000 + 1500	400/230
D(R)PV ... 60	1500 + 1500	400/230
D(R)PV ... 70	1500 + 2330	400/230
D(R)PV ... 80	1500 + 2330	400/230
D(R)PV ... 90	1500 + 2330	400/230

One heater is also possible.

Oil drain valves

Oil drain valves

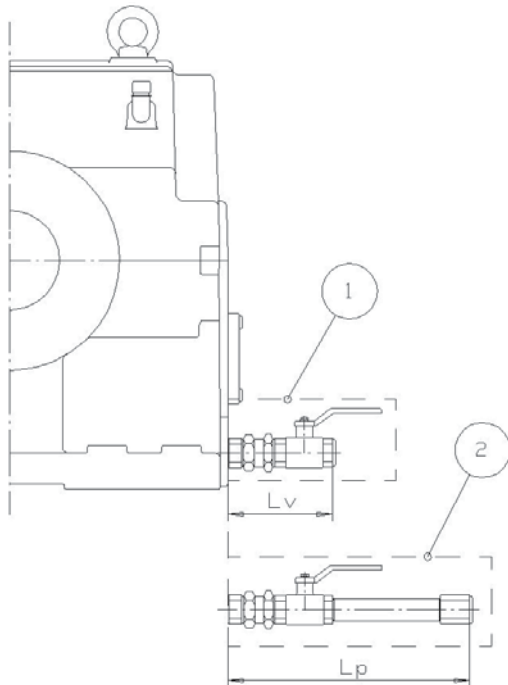

Size of the oil drain valve depends on the size of gear unit.

Oil drain valve can be furnished with an extension tube.

Standard lengths (Lp) are in table. Other lengths are also possible.

Oil drain valve lengths

Size	Length Lv	Lenght Lp	
R ½	100	-	-
R ¾	115	290	430
R 1	140	300	450
R 1 ½	175	350	470

Oil dipstick, oil filler plug

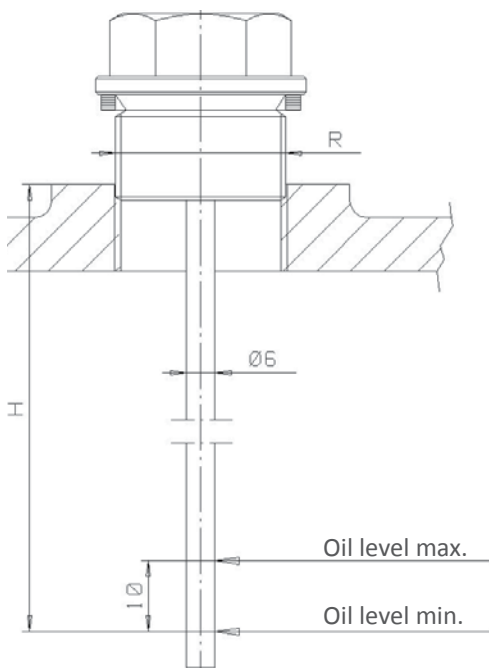

Oil level H is indicated when the oil filler plug is unscrewed.

Oil level can be checked only when gear unit is not running.

Water and dirt penetration into the gear unit must be prevented while checking the oil level.

Oil sightglass and breather

Oil sightglass and breather

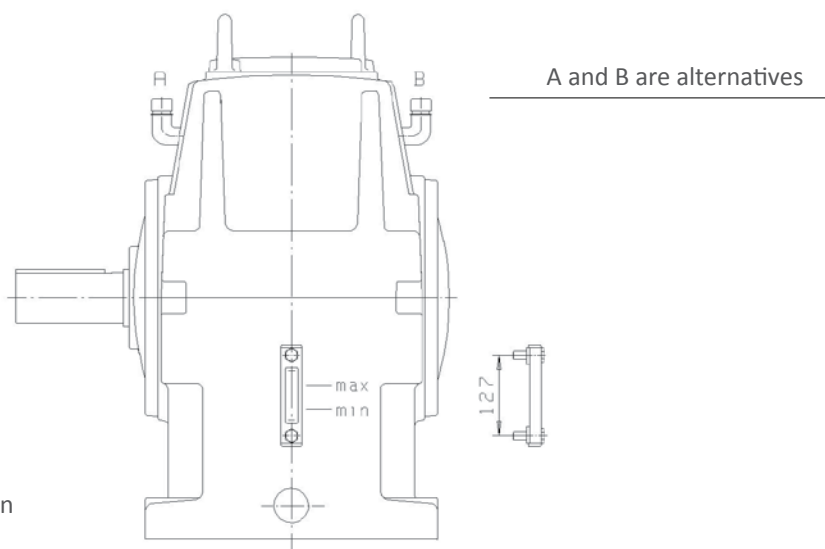

Oil level can be checked only when the gear unit is not running.

Oil sightglass and breather are standard equipments of the gear unit. Filtration degree of the standard breather is 40 μ m.

Air breather prevents the forming of over pressure inside the gear unit and prevents dirt penetration into the gear unit.

Expansion tank for moist environment

A rubber diaphragm is used inside the expansion tank to prevent dirt and water from getting inside the gear unit.

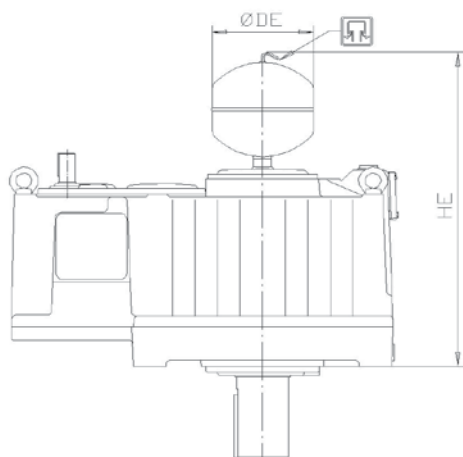

Size	HE (max)	Ø DE
10	675	315
20	700	315
30	775	315
40	800	315
50	950	315
60	1050	315
70	1200	450
80	1275	450
90	1350	450

Optional seal arrangements

Optional seal arrangements

Seal arrangement selection does not effect on outer shaft end dimensions.
Standard seal arrangement for each gear unit type are introduced in section 3.

Horizontal shaft, both high speed shaft (HSS) and low speed shaft (LSS)

Seal arrangement alternatives on each shaft:

- * single lip seal with dust protection cover (basic solution) - clean environment
- * double lip seal with regreaseable dust protection cover - dusty environment with abrasive particles
- * labyrinth seal - high rotating speeds or high running temperatures

Vertical high speed shaft (HSS) upwards

- * single lip seal with dust protection cover (basic solution)

Vertical high speed shaft (HSS) downwards

- * double lip seal with dust protection cover

Vertical low speed shaft (LSS) upwards

- * single lip seal with dust protection cover (basic solution)
 - clean environment
- * double lip seal with regreaseable dust protection cover
 - wet and/or dusty environment with abrasive particles

Vertical low speed shaft (LSS) downwards

- * double lip seal with dust protection cover (basic solution)

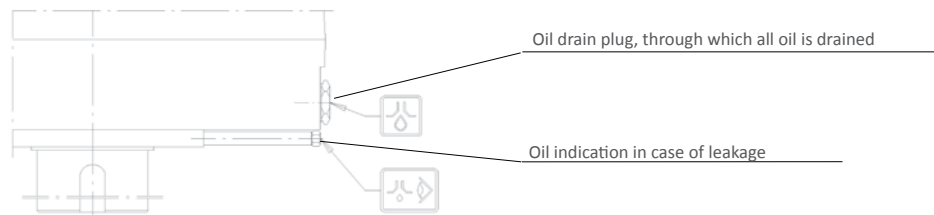

- * Dry well
 - Single lip seal with dust protection cover
 - gear unit is equipped with shaft end pump (page 4.17)

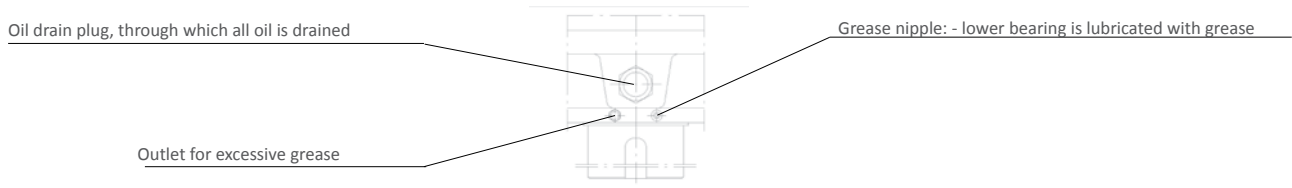

Lip seal material

- * NBR
 - when the running temperature of the oil is less than 80 °C
- * VITON
 - when the running temperature of the oil is over 80 °C
 - when hot media is flowing through the low speed shaft
 - warming up the seal surfaces
 - when outside source radiates heat on the seal warming it up
 - always on HSS

VITON is less sensitive to become hard than NBR in high temperatures.

Coupling guard

Coupling guard attached to the gear unit

HELICAL GEAR UNITS

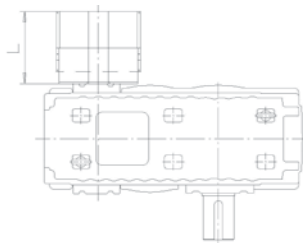

Size	Max. coupling diameter	Max. shaft diameter *)	Length [L]	Diameter [D]
1	140	65	138-190	216
2	140	65	190-294	216
3	230	105	190-294	306
4	230	105	297-483	306
5	290	105	297-483	408
6	360	145	297-483	436
7	470	205	483-830	546
8	570	250	483-830	646

*) Max shaft diameter of driving/driven machine

BEVEL-HELICAL GEAR UNITS/

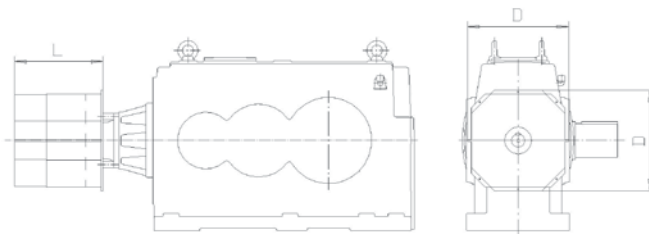

When cooling fan is used the coupling guard is fixed separately.

Torque arm

When ordering the torque arm, dimension HA must be advised. It can be freely chosen between HA_{MIN} - HA_{MAX} . If HA is to be longer than HA_{MAX} the torque reaction arm will be of special design.

The dimensioning of the foundation shall comply with the load data provided by the equipment supplier.

TC 140 - 400
TKC. 90 - 400
D...50 - 90

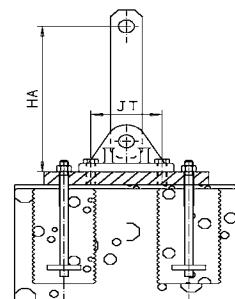

1. and 2. are included in delivery

TC 140 - 400
TKC. 90 - 400
D...50 - 90

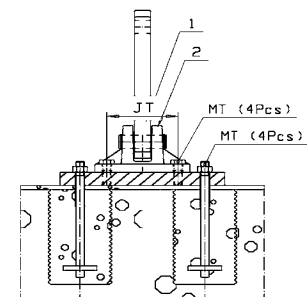

D...100 - 160

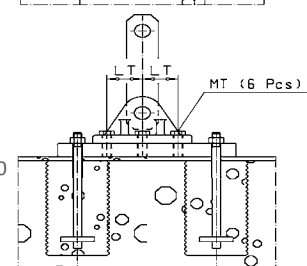

Size	HA	JT	MT	F_{MAX}	
TC140N-250N					
TKC90N-400N					
TKCV140N-400N					
90N - 200N	90 ... 650	90	M16	75 kN	
225N - 250N	125 ... 950	125	M20	125 kN	
315N - 400N	175 ... 1070	180	M24	330 kN	
D...50-90					
50	125 ... 950	125	M20	200 kN	
60 - 90	175 ... 1070	180	M24	400 kN	
D...100-160					
100 - 110	240 ... 1300	300	115	M30	520 kN
120 - 130	240 ... 1100	350	140	M36	620 kN
140 - 160	400 ... 1400	400	180	M42	900 kN

Belt drive

Belt drive

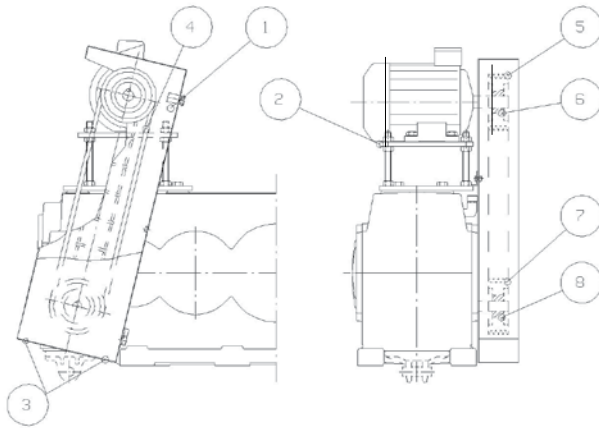

- Components:
- 1. Belt guard
 - 2. Motor bracket
 - 3. Water drain
 - 4. V - belts
 - 5. Pulley (dp)
 - 6. Taper bushing
 - 7. Pulley (Dp)
 - 8. Taper bushing

Motor flange

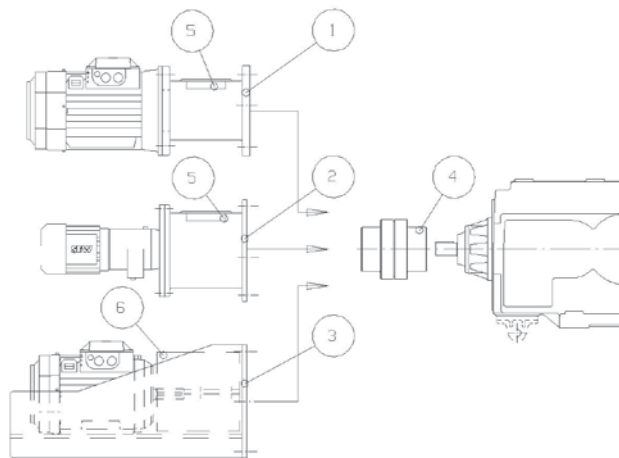

- Components:
- 1. Motor flange
 - 2. Gearmotor flange
 - 3. Sugar scoop
 - 4. Coupling
 - 5. Inspection cover
 - 6. Coupling guard

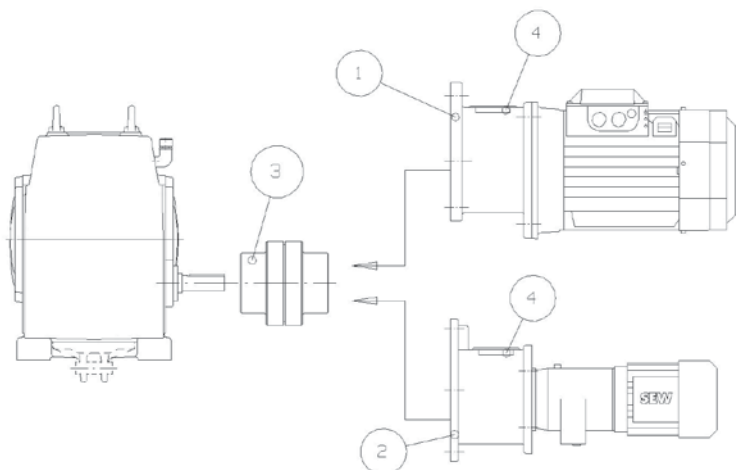

- Components:
- 1. Motor flange
 - 2. Gearmotor flange
 - 3. Coupling
 - 4. Inspection cover

Back stop

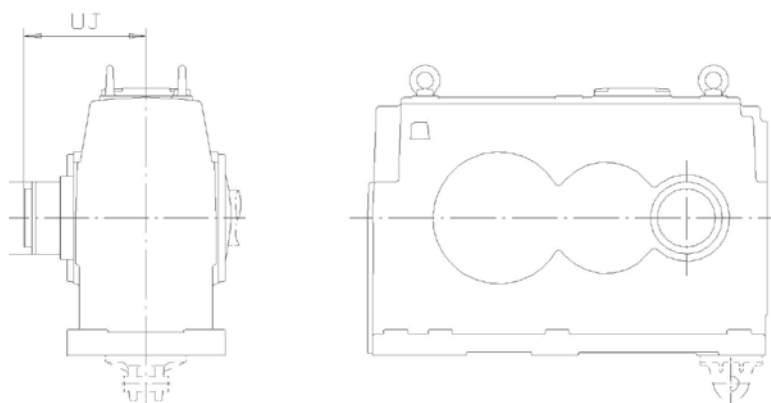

Backstops are dimensioned to brake output torques up to gear unit nominal output torque M_{N2} .

Gear units types D2P ..

Size	$i_N = 6.3...12.5$ $n_1 > 420$ 1/min			$i_N = 14...18$ $n_1 > 450$ 1/min		
	Backstop	$\varnothing D$	UJ	Backstop	$\varnothing D$	UJ
50	RSCI 60	175	308	RSCI 50	150	284
60	RSCI 80	210	345	RSCI 60	175	335
70	RSCI 80	210	374	RSCI 60	175	364
80	RSCI 90	230	407	RSCI 70	190	387
90	RSCI 100	290	451	RSCI 80	210	429

Gear units types D3P ..

Size	$i_N = 20...40$ $n_1 > 480$ 1/min			$i_N = 45...90$ $n_1 > 600$ 1/min		
	Backstop	$\varnothing D$	UJ	Backstop	$\varnothing D$	UJ
50	RSCI 40	125	270	RSCI 30	100	265
60	RSCI 50	150	302	RSCI 40	125	297
70	RSCI 60	175	359	RSCI 45	130	330
80	RSCI 60	175	377	RSCI 50	150	353
90	RSCI 70	190	399	RSCI 60	175	399

Gear units types D4P ..

Size	$i_N = 100...180$ $n_1 > 720$ 1/min			$i_N = 200...400$ $n_1 > 780$ 1/min		
	Backstop	$\varnothing D$	UJ	Backstop	$\varnothing D$	UJ
50	RSCI 25	95	259	RSCI 20	90	259
60	RSCI 25	95	286	RSCI 20	90	286
70	RSCI 35	110	320	RSCI 25	95	320
80	RSCI 35	110	338	RSCI 25	95	338
90	RSCI 40	125	365	RSCI 30	100	360

Back stop

Back stop

Gear units types D3R ..

Size	$i_N = 14...28$			$i_N = 31.5...80$		
	$n_1 > 1050 \text{ 1/min}$			$n_1 > 1800 \text{ 1/min}$		
	Backstop	ϕD	UJ	Backstop	ϕD	UJ
50	RSCI 50	150	284	RSCI 50	150	284
60	RSCI 60	175	335	RSCI 60	175	335
70	RSCI 70	190	364	RSCI 70	190	364
80	RSCI 80	210	397	RSCI 70	190	387
90	RSCI 90	230	439	RSCI 80	210	429

Size	$i_N = 14...28$			$i_N = 31.5...80$		
	$n_1 > 1050 \text{ 1/min}$			$n_1 > 1800 \text{ 1/min}$		
	Backstop	ϕD	UJ	Backstop	ϕD	UJ
50	AA 50	150	308	AA 50	150	308
60	AA 50	150	335	AA 50	150	335
70	AA 60	170	382	AA 60	170	382
80	AA 70	190	422	AA 60	170	405
90	AA 70	190	454	AA 70	190	454

Gear units types D4R ..

Size	$i_N = 90...160$		
	$n_1 > 2150 \text{ 1/min}$		
	Backstop	ϕD	UJ
50	RSCI 35	110	245
60	RSCI 40	125	277
70	RSCI 50	150	330
80	RSCI 50	150	331
90	RSCI 60	175	377

Size	$i_N = 90...160$			$i_N = 180...315$		
	$n_1 > 2150 \text{ 1/min}$			$n_1 > 3000 \text{ 1/min}$		
	Backstop	ϕD	UJ	Backstop	ϕD	UJ
50	AA 35	110	254	AA 30	100	250
60	AA 35	110	281	AA 35	110	281
70	AA 45	130	324	AA 40	125	324
80	AA 50	150	349	AA 45	130	342
90	AA 50	150	371	AA 50	150	371

Gear units types D5R ..

Size	$i_N = 355...1800$		
	$n_1 > 2370 \text{ 1/min}$		
	Backstop	ϕD *)	UJ
50	AE 30	-	203
60	AE 30	-	230
70	AE 40	-	259
80	AE 40	-	277
90	AE 50	-	301

Recommended HSS (n1) speeds should be less than 3000 1/min.

*) Backstop is inside bearing housing.

Swing base for motor

Swing bases for conveyor drives are designed and manufactured according to order.

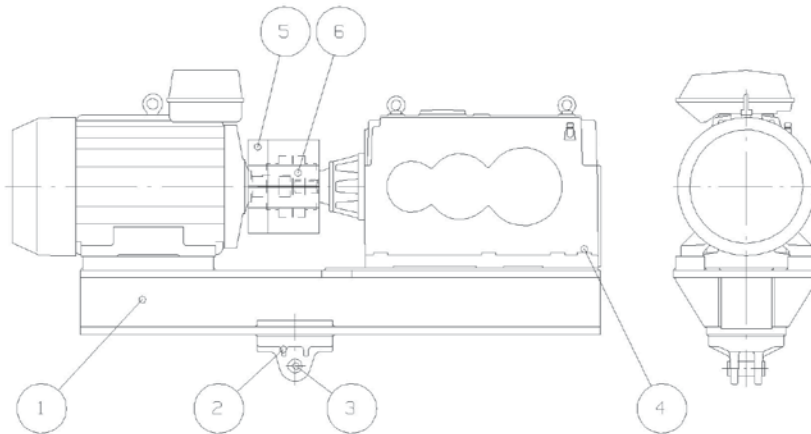

1. Swing base beam
2. Torque arm mounting bracket
3. Torque arm pin
4. Fastening screws
5. Coupling guard
6. Coupling

Sensors

Shock Impulse sensor

Nipple STD-2 UNC5/16 and cover STE-01

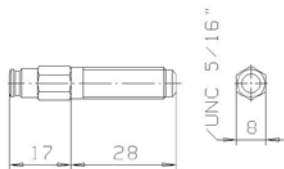

Nipple 32000 and cover 81025

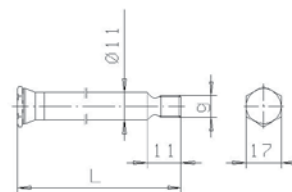

g	L(mm)
M8 (UNC 5/16")	24 113 202 291

Standard

Sensor to be wired 40000 and fitting 13008

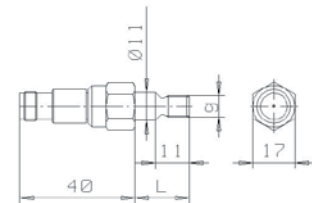

g	L(mm)
M8 (UNC 5/16")	17 106 195 284

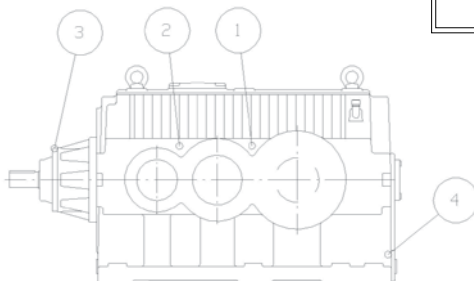

1 2 3 Example of bearing sensor position

4 Example of oil temperature sensor position

Oil temperature sensor (PT100)

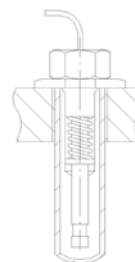

Bearing temperature sensor (PT100)



Modifications

Modifications

Pinion stand, (Type D .. ST)

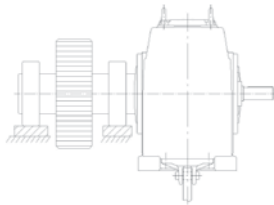

Shrink fit coupling

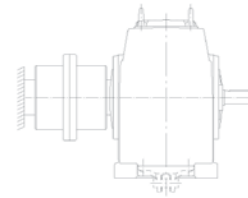

Gear wheel assembled on output shaft end

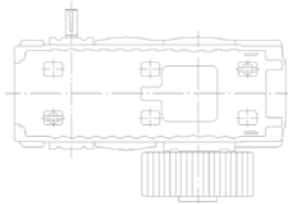

Shrink disk coupling

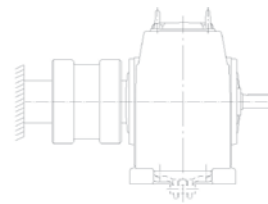

Shaft end with splines

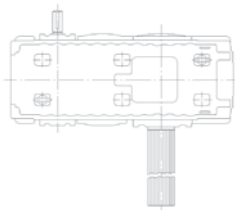

Through going hollow shaft

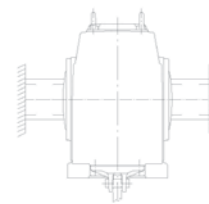

Oil drain plugs position D2P., D3R..

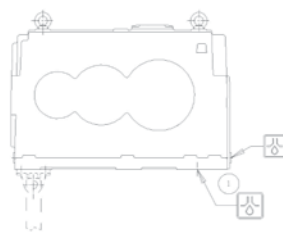

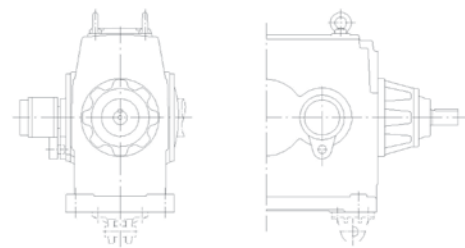

Backstop type (GFR), (RIZ)

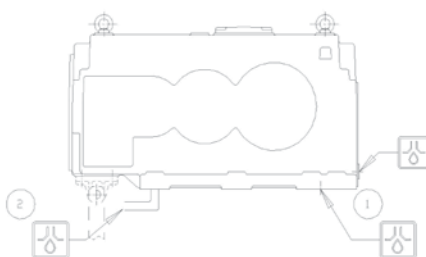

Oil drain plugs position D3P., D4P., D4R., D5R..



-  = Oil drain, standard position
-  = Oil drain, optional position

OTHER MODIFICATIONS: Available separate seal bushing on LSS

Modifications

Pinion stand, (Type D .. ST)

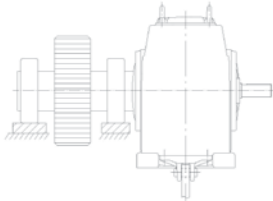

Shrink fit coupling

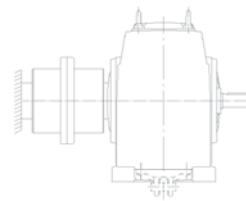

Gear wheel assembled on output shaft end

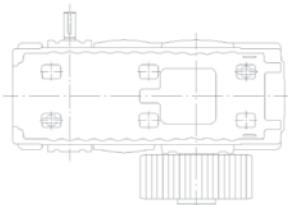

Shrink disk coupling

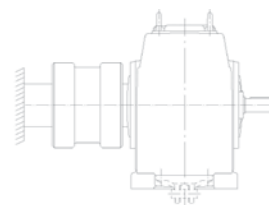

Shaft end with splines

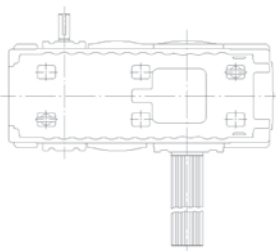

Through going hollow shaft

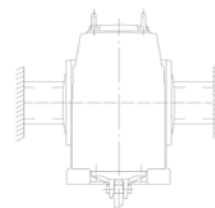

OTHER MODIFICATIONS: Available separate seal bushing on LSS

Our Locations

Americas

- **Brazil**
Sorocaba, São Paulo
T: + 55 15 3031 5300
E: brasil@santasalo.com

Canada

- Cambridge, Ontario
T: + 1 519 621 6390
F: + 1 519 621 7660
E: canada@santasalo.com

Chile

- Santiago
T: + 562 2920 6778
E: chile@santasalo.com

USA

- Greenville, SC
T: + 1 864 627 1700
F: + 1 864 627 1705
E: usa@santasalo.com

- | | |
|---------------------|----|
| Manufacturing plant | ●● |
| Service centre | ●● |
| Sales office | ● |

Europe

- Finland
Jyväskylä
T: + 358 293 401 000
F: + 358 20 184 7101
E: finland@santasalo.com

- France
Bordeaux
T: + 33 547 745 402
F: + 33 547 745 403
E: france@santasalo.com

- Germany
Wuppertal
T: + 49 202 24 14 0
F: + 49 202 24 14 200
E: germany@santasalo.com

- Italy
Milan
T: + 39 349 0826296
E: italy@santasalo.com

- Spain
Madrid
T: + 34 91 48 61 518
E: spain@santasalo.com

- Sweden
Gothenburg
T: + 46 31 710 20 50
F: + 46 31 710 20 60
E: sweden@santasalo.com

Asia Pacific

- Australia
Somersby
T: + 61 2 4340 2338
F: + 61 2 4340 2339
E: australia@santasalo.com

- China
Suzhou
T: + 86 512 6299 8852
F: + 86 512 6299 8853
E: suzhou@santasalo.com

- China
Beijing
T: + 86 10 6775 6792
F: + 86 10 6778 2312
E: beijing@santasalo.com

Africa

- South Africa
Johannesburg
T: + 27 (0)11 452 3044/5/6
F: + 27 (0)11 524 0490
E: southafrica@santasalo.com



Scan our QR code for quick
access to our website

www.santasalo.com